

2017



THE EXHIBITORS'™  
**HAND  
BOOK**  
MODULAR DISPLAY SOLUTIONS

*Finding* IDEAS  
INNOVATION  
CREATIVITY  
COMMUNICATION

WHERE YOUR *BRAND*  
TAKES FLIGHT.



# PORTABLE *DISPLAYS*

## **PORTABLE DISPLAYS**

Portable displays are designed for easy use and to prominently represent your brand and message.

They are a means of advertising in retail settings, public places of all types and in face-to-face events such as trade shows, media events, fairs and expositions. Portable displays are quick and simple to install.

# MODULAR *SYSTEMS*

## **MODULAR DISPLAYS & FABRIC STRUCTURES**

Modular exhibits typically feature extrusion-based frames and fabric graphics, are sophisticated in design and are often customizable and reconfigurable. Modular display sizes span from tabletop to 10 feet and 20 feet inline to island sizes.

Fabric structures and displays combine zipper pillowcase fabric graphics with lightweight aluminum tube structures. From exhibit kits to hanging signs, arches and other architectural structures, these displays are ideal for use in tradeshow, as retail displays and in corporate spaces to add advertising with style.

# PORTABLE DISPLAYS

## 4 | BANNER STANDS

RETRACTABLE | TELESCOPIC | SPRING BACK



## 15 | MODULAR BANNER SYSTEMS

CAFÉ BARRIER



## 16 | FORMULATE® ESSENTIAL BANNER DISPLAYS



## 20 | VECTOR FRAME™ BANNER DISPLAYS

LIGHT BOXES | BANNERS | KIOSKS



## 24 | OUTDOOR DISPLAYS

TENTS | FLAGS | SIGNAGE



## 34 | TABLE THROWS & RUNNERS

### SYMBOLS USED:



product made in North America



economy product



standard product



premium product



product can be recycled (does not include graphic)



product comes with a carry bag or case



rental product



new product

# PORTABLE DISPLAYS

HOPUP™ TENSION FABRIC DISPLAYS | 38



EMBRACE™ PUSH-FIT FABRIC DISPLAYS | 44



XCLAIM™ FABRIC POPUP DISPLAYS | 52



COYOTE™ POPUP DISPLAY SYSTEMS | 60



FOLDING DISPLAY PANELS | 66



ACCENTS & ACCESSORIES | 70  
COUNTERS | LIGHTS | CASES



## WARRANTY KEY:



lifetime limited warranty (hardware)



5 year limited warranty (hardware)



1 year limited warranty (hardware)



90 day limited warranty (hardware)



graphics limited 1 year warranty (indoor products)



graphics limited 6 month warranty (outdoor & table throw products)

# FABRIC DISPLAYS & STRUCTURES

88 | **MODULATE**

MIX & MATCH | 10', 20', 30' KITS



94 | **FORMULATE® ESSENTIAL**

BANNERS | TABLETOP DISPLAYS | 8' DISPLAYS | 10' DISPLAYS



98 | **FORMULATE MASTER**

TABLETOP DISPLAYS | 10' DISPLAYS | 20' DISPLAYS | ACCENTS



116 | **FORMULATE DESIGNER SERIES**

10' DISPLAYS | 20' DISPLAYS | 30' DISPLAYS



132 | **FORMULATE FUSION 20' X 20' ISLAND KITS**



140 | **FORMULATE HANGING & ARCHITECTURAL STRUCTURES**

HANGING SIGNS | TOWERS | ARCHES | CONFERENCE WALLS

## SYMBOLS USED:



product made in North America



economy product



standard product



premium product



product can be recycled (does not include graphic)



product comes with a carry bag or case



rental product



new product

# MODULAR EXHIBIT SYSTEMS

## HYBRID PRO™ MODULAR DISPLAYS | 160

10' DISPLAYS | 20' DISPLAYS | ISLANDS



## VECTOR FRAME™ MODULAR DISPLAYS | 170

BANNER DISPLAYS | 10' DISPLAYS | 20' DISPLAYS | ACCENTS



## LINEAR™ PRO MODULAR DISPLAYS | 184

10' DISPLAYS | 20' DISPLAYS | ACCENTS



## MERCHANDISE EXPRESS™ MODULAR DISPLAYS | 188

POINT OF PURCHASE DISPLAYS



## ORBITAL EXPRESS™ TRUSS MODULAR DISPLAYS | 192

10' DISPLAYS | 20' DISPLAYS | ISLANDS | ACCENTS

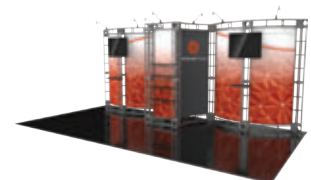

## ACCENTS & ACCESSORIES | 212

COUNTERS | LIGHTS | CASES



### WARRANTY KEY:



lifetime limited warranty (hardware)



5 year limited warranty (hardware)



1 year limited warranty (hardware)



90 day limited warranty (hardware)



graphics limited 1 year warranty (indoor products)



graphics limited 6 month warranty (outdoor & table throw products)

# BANNER STANDS



## FAST. CLEAR. COMMUNICATION.

Largest selection of banner stand choices and options • Premium, mid-range and economy stands • Retractable, Telescopic and Spring Back options • Great quality • High-end functionality, features and durability • Specifically designed with unique styling points, giving an exceptional appearance • Multiple accessory and light options



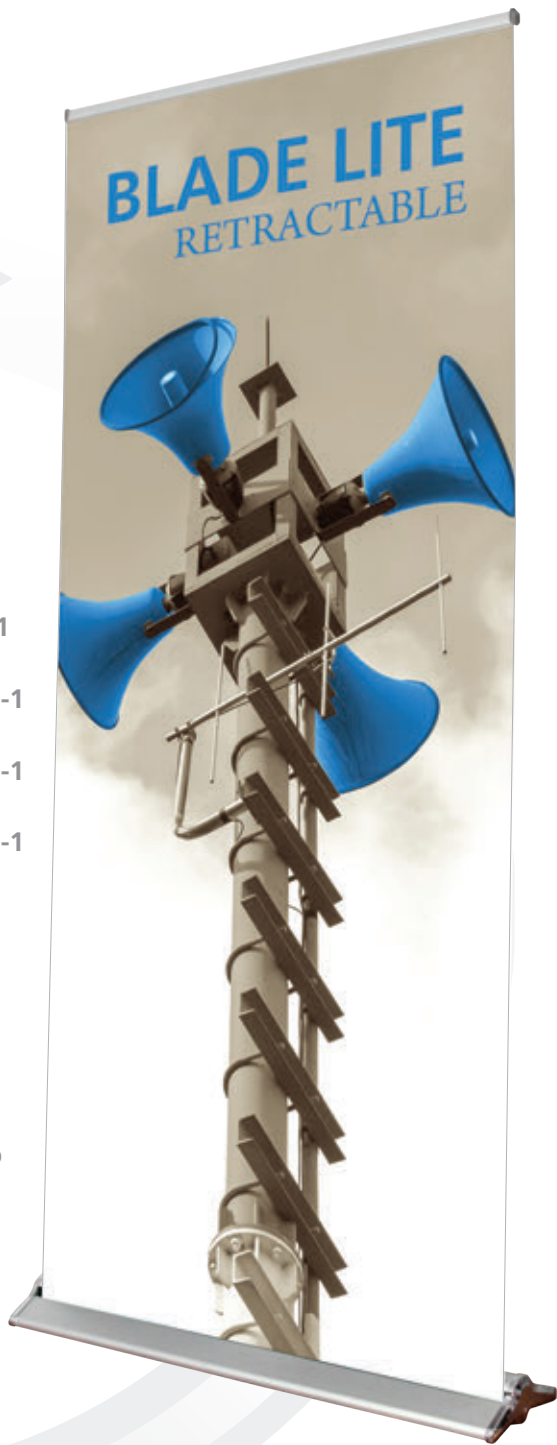

## BLADE LITE

**NEW**  
*Size*

**15.75" WIDE** BLD-LT-400-1

**36" WIDE** BLD-LT-920-1

**23.5" WIDE** BLD-LT-600-1

**39.25" WIDE** BLD-LT-1000-1

**31.5" WIDE** BLD-LT-800-1

**47.25" WIDE** BLD-LT-1200-1

**33.5" WIDE** BLD-LT-850-1

**59" WIDE** BLD-LT-1500-1

- 400mm standard graphic height = 69.38"
- 600mm variable graphic height = 69" - 83.25"
- 800-1500mm variable graphic height = 60" - 83.25"
- eight widths to choose from: 15.75", 23.5", 31.5", 33.5", 36", 39.25", 47.25", 59"
- toolless quick rail combines the ease of a snap rail with the reassurance of an adhesive fixing
- weighted base for stability
- adjustable leveling feet
- hybrid bungee/telescopic pole



# PREMIUM RETRACTABLE BANNER STANDS



Premium Retractable banner stands provide superior, high-end functionality, features and durability, as well as unique styling points for exceptional appearance. Premium banners include a protective, carry bag and feature a lifetime hardware warranty.

## IMAGINE

**31.5" WIDE** IMG-800-S

- variable graphic height = 30.5" - 83.35"
- graphic tensioner
- integrated pole storage
- interchangeable graphic cassette
- adjustable feet on base
- telescopic pole
- shown with optional literature pocket accessory (AKIT-1S1L)



## BARRACUDA

**23.5" WIDE** BCD-600-S-1 **NEW** *Size*

**31.5" WIDE** BCD-800-S-1

**33" WIDE** BCD-850-S-1 **NEW** *Size*

**35.5" WIDE** BCD-920-S-1

**47.25" WIDE** BCD-1200-S-1 **NEW** *Size*

- 600mm variable graphic height = 66.5" - 83"
- 800-1200mm variable graphic height = 60" - 83"
- anodized silver base
- toolless quick rail
- graphic tensioner
- adjustable feet on base
- hybrid bungee/telescopic pole



## ADVANCE

**31.5" WIDE** ADV-800-S

- variable graphic height = 29.5" - 83.35"
- double sided
- graphic tensioner
- integrated pole storage
- interchangeable graphic cassette
- adjustable feet on base
- telescopic pole

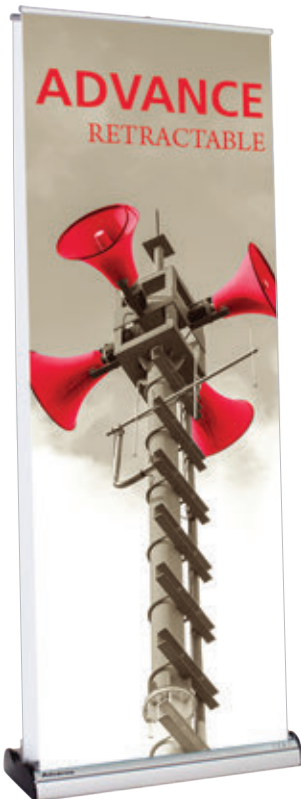

## EXCALIBUR

**31.5" WIDE** EXC-800-S-1

**35.5" WIDE** EXC-920-S-1

- variable graphic height = 60" - 83"
- double sided
- anodized silver base
- toolless quick rail combines the ease of a snap rail with the reassurance of an adhesive fixing
- graphic tensioner
- adjustable feet on base
- hybrid bungee/telescopic pole
- shown with optional tabletop accessory (AKIT-1S)

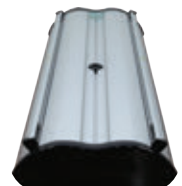



## PREMIUM RETRACTABLE BANNER STAND ACCESSORIES

Premium Banner Stand Accessories add style and functionality to any premium stand, single or double sided. Shelf and literature pockets instantly turn select premium stands into a robust display solution by adding tabletop real estate for business cards, small products and a literature pocket to hold brochures.

### OPTIONAL PREMIUM BANNER STAND ACCESSORIES

kit 01 includes shelf & lit pocket: AKIT-1S1L

kit 02 includes shelf: AKIT-1S

kit 03 includes lit pocket: AKIT-1L

- works with single and double sided premium stands
- extrusion uprights fit into channel on stand base and lock in place easily
- shelf offered in black laminate; holds up to 5 lbs.
- wire literature rack holds up to 5 lbs. of literature, 8.5" w x 11" h in size



#### Shelf Setup



#### Table Setup



**NEW**

### REVOLUTION

**33.5" WIDE** RVLTN-850

- variable graphic height = 61.5" - 86.5"
- white, injection molded banner stand
- toolless quick rail combines the ease of a snap rail with the reassurance of an adhesive fixing
- hybrid bungee/telescopic pole
- graphic tensioner



# STANDARD RETRACTABLE BANNER STANDS



Standard Retractable banner stands incorporate customary features designed to provide everyday reliability, durability and ease of use. Standard banners include a mid-range canvas carry bag and typically feature a five-year to lifetime hardware warranty.

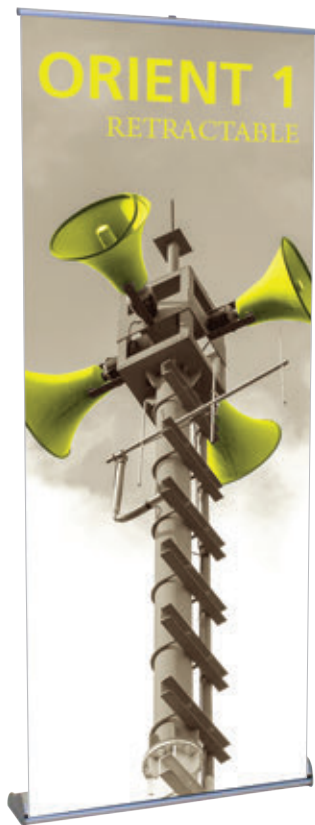

## ORIENT 1

**31.5" WIDE** silver: ONT-800-S-4  
black: ONT-800-B-4

**33.5" WIDE** silver: ONT-850-S-4  
black: ONT-850-B-4

**35.5" WIDE** silver: ONT-920-S-4  
black: ONT-920-B-4

**39.25" WIDE** silver: ONT-1000-S-4  
black: ONT-1000-B-4

- variable graphic height = 60.5" - 83.25"
- anodized silver or black base options
- toolless quick rail combines the ease of a snap rail with the reassurance of an adhesive fixing
- molded end caps
- adjustable feet on base
- hybrid bungee/telescopic pole



## ORIENT 2

**31.5" WIDE** ONT-800-DBL-S-4

**35.5" WIDE** ONT-920-DBL-S-4

- variable graphic height = 60.5" - 83.25"
- double sided
- anodized silver base
- toolless quick rail combines the ease of a snap rail with the reassurance of an adhesive fixing
- molded end caps
- adjustable feet on base
- hybrid bungee/telescopic pole



## PACIFIC

**31.5" WIDE** PAC-800-S-2

**35.5" WIDE** PAC-920-S-2

**39.25" WIDE** PAC-1000-S-2

- standard graphic height = 83.75"
- anodized silver base
- molded end caps
- swivel-out foot
- 3-piece bungee pole



## CONTENDER



**23.5" WIDE** silver: CN-24-S  
black: CN-24-B

**29.5" WIDE** silver: CN-30-S  
black: CN-30-B

**35.5" WIDE** silver: CN-36-S  
black: CN-36-B

**47.5" WIDE** black: CN-48-B

- standard graphic height = 77.5"
- swivel-out foot
- silver or black base options
- laser cut steel ends & 3-piece pole





# STANDARD RETRACTABLE BANNER STANDS

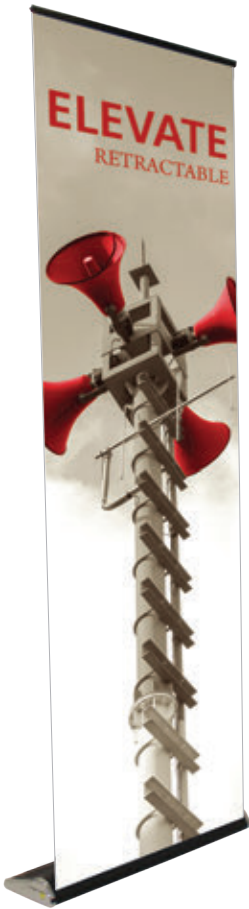

## ELEVATE

33.25" WIDE ELEVATE

- variable graphic height = 31.5" - 95.25"
- roller access via flip-top lid and removable graphic roller
- black aluminum body with chrome end caps
- telescopic pole

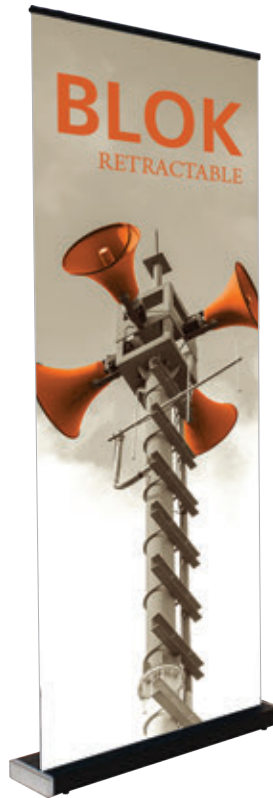

## BLOK

33.5" WIDE BLOK-850

- standard graphic height = 79.25"
- snap top graphic rail
- black base with chrome end caps
- 3-piece bungee pole



## CRESCENT

33.25" WIDE CRESCENT

- standard graphic height = 78.25"
- snap top graphic rail
- silver base with black end caps
- 3-piece bungee pole



## MERLIN

33.5" WIDE MRLN-850



- variable graphic height = 61.5" - 88"
- anodized silver base
- snap top graphic rail
- hybrid bungee/telescopic pole
- interchangeable plastic cassette



# ECONOMY RETRACTABLE BANNER STANDS



Economy Retractable banner stands incorporate basic design features, functionality and reliability. Economy banners include a basic carry bag and feature a 90-day hardware warranty.



## START

**31.25" WIDE** STRT-800-C

- standard graphic height = 79.25"
- snap top graphic rail
- swivel feet
- anodized silver base
- chrome end caps
- 3-piece bungee pole



## SOLO

**31.25" WIDE** SOLO-800

**35.5" WIDE** SOLO-920

- standard graphic height = 79"
- snap top graphic rail
- swivel foot
- 3-piece bungee pole



## DRAGON FLY

**33.25" WIDE** DRAGON FLY

- standard graphic height = 79"
- double sided
- snap top graphic rail
- swivel feet
- 3-piece bungee pole



## QUICKSTAND

**31.5" WIDE** QWK-STND-S

- standard graphic height = 78.5"
- anodized silver base
- kit includes 1 Mosquito 800 banner stand, 1 OCB banner stand case, and 1 Lumina 5 banner stand light
- swivel feet
- snap top graphic rail
- 3-piece bungee pole





## ECONOMY RETRACTABLE BANNER STANDS

### MOSQUITO

**31.5" WIDE** silver: MSQT-800  
black: MSQT-800-B

**47.25" WIDE** silver: MSQT-1200

**59" WIDE** silver: MSQT-1500

- standard graphic height = 78.5"
- anodized silver or black base options (800mm only)
- swivel feet & snap top graphic rail
- 800mm unit is supplied with one bungee pole, 1200mm and 1500mm come with two bungee poles

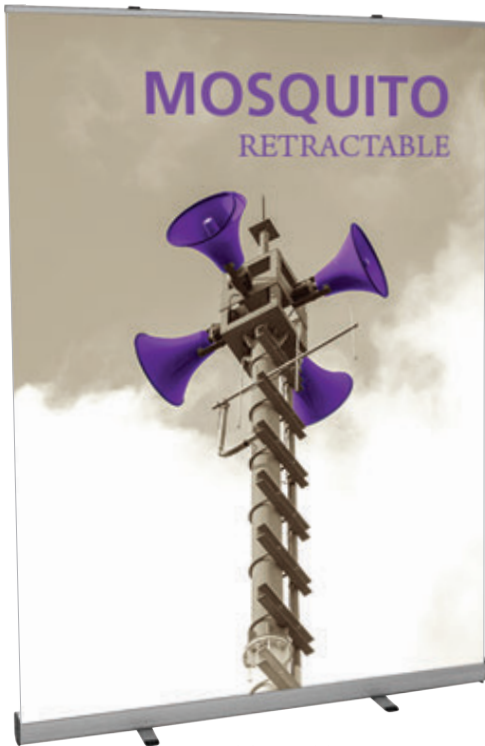
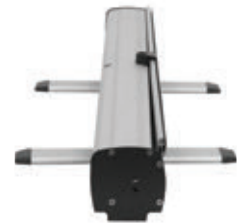

MSQT-1500



MSQT-1200



MSQT-800



### GIANT MOSQUITO

**36" WIDE** MSQT-GIANT-920-S

- variable graphic height = 68" - 122"
- over 10' tall
- anodized silver base
- swivel feet
- snap top graphic rail
- adjustable telescopic pole
- heavy duty, weighted stand

*shown at maximum height*



### MOSQUITO LITE

**31.5" WIDE** MSQT-LT-800

- standard graphic height = 78.5"
- anodized silver base
- swivel foot
- snap top graphic rail
- 3-piece bungee pole



# ECONOMY RETRACTABLE BANNER STANDS



Economy Retractable banner stands incorporate basic design features, functionality and reliability. Economy banners include a basic carry bag and feature a 90-day hardware warranty.



## PHOENIX

**33.5" WIDE** PHX-850-S

- standard graphic height = 79" h
- anodized silver base
- swivel feet
- snap top graphic rail
- 3-piece bungee pole



## PHOENIX MINI

**15.5" WIDE** PHX-400-S

- four graphic height options = 16.5", 31.5", 47.25", 63" (two largest heights require extension pole kit)
- anodized silver base
- 2-piece pole & optional extenders for added height
- comes complete with carry bag
- tabletop or skinny full-height banner stand



## BREEZE

**8.5" WIDE** BREZ-1-S: 8.5"w x 11"h

**11" WIDE** BREZ-2-S: 11"w x 17"h

- retractable tabletop banner stand
- ideal for promotional use

## STELLAR



**8.5" WIDE** STLLR-LTR: 8.5"w x 11"h

**11" WIDE** STLLR-TBLD: 11"w x 17"h

- retractable tabletop banner stand
- injection molded/plastic base
- ideal for promotional use

dye sublimated and round stretch table throws can be seen on p. 35 and 36





# STANDARD TELESCOPIC BANNER STANDS

Standard Telescopic banner stands incorporate customary features designed to provide everyday reliability, durability and ease of use. Standard banners include a mid-range canvas carry bag and typically feature a one-year hardware warranty.



## EXPOSÉ

**94.5" WIDE** EXP-SS-S  
EXP-SS-C  
EXP-DS-S

- variable graphic height = 33" - 85"
- straight and curved options available
- straight offered with front graphic and optional back graphic
- flat, low profile bases
- easy assembly



Curved option



top and bottom clamps hold rails in place



telescopic poles for adjustable height



## TRIO

**31.5" WIDE** TRIO

- variable graphic height = 28.75" - 84"
- tri-pod banner stand
- hardware included supports single and double sided graphic
- stable, anodized aluminum
- telescopic pole for adjustable graphic height
- quick & easy to set up
- includes hardware for double sided graphics



3 pocket add-on literature dispenser  
**TRIO-LP**



## PEGASUS SUPREME

**63.5" - 117.5" WIDE** silver: PGSUS3-S  
black: PGSUS3-B

- Supreme variable graphic height = 82.75" - 119"
- single or double sided graphics
- linking connectors attach multiple units together
- telescopic poles for adjustable graphic width and height

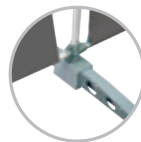

## PEGASUS LINKING KIT

Supreme silver: PGSUS3-EXT-S  
Supreme black: PGSUS3-EXT-B  
Standard silver: PGSUS2-EXT-S  
Standard black: PGSUS2-EXT-B

- linking connectors attach multiple Pegasus units together
- extension kit includes 2 horizontal poles, 1 vertical pole, pole locks, 2 linking connectors & 1 foot



## PEGASUS STANDARD

**51.5" - 94" WIDE** silver: PGSUS2-S  
black: PGSUS2-B

- Standard variable graphic height = 67.75" - 96.5"
- single or double sided graphics
- linking connectors attach multiple units together
- telescopic poles for adjustable graphic width and height

# ECONOMY SPRING BACK BANNER STANDS



Economy Spring Back banner stands incorporate basic design features, functionality and reliability. Economy banners include a basic carry bag and feature a 90-day hardware warranty. Also available in bulk buying options.



## LIGHTNING

31" WIDE LTNG

- standard graphic height = 77"
- snap-lock graphic rails
- 3-piece bungee pole



## L-MINI

14.25" WIDE L-MINI

- standard height = 26.88"
- tabletop tension banner stand
- adhesive rail
- anodized silver finish



## SPRING 3

27.5" WIDE SB-3

- standard graphic height = 70.75"
- #3 grommets in corners
- single or double sided



## SPRING 7

29.5" WIDE SB-7

- variable graphic height = 61.5" - 69"
- #3 grommets in corners





## CAFÉ BARRIER

CB-K-1500

CB-EXT-K-1500

- indoor/outdoor modular display system
- stylish way to define areas or dictate traffic flow in or outside restaurants, bars, retail establishments, airports, museums, casinos and at tradeshows
- visual graphic area = approx. 53.25" w x 30.5" h
- heavy-duty stainless steel posts, base and 59" w rails
- unit kit, extension kit and individual components available

### Café Barrier Kit:

CB-K-1500

- comes with top and bottom poles – 59" w, 2 uprights & 2 bases

### Café Barrier Extension Kit:

CB-EXT-K-1500

- comes with top and bottom poles – 59" w, 1 upright & 1 base



*great for outdoor use!*



*use as outdoor barriers*



*use for crowd control*



*use to guide traffic*

# FORMULATE® ESSENTIAL BANNER DISPLAYS



Formulate® Essential banner displays feature basic tubular frames coupled with pillowcase fabric graphics. The economy tube frames come with a one-year limited warranty. Simply pull the graphic over the frame.



## FORMULATE ESSENTIAL BANNER – STRAIGHT

**23.5" WIDE** FMLT-ESS-S-600

**36" WIDE** FMLT-ESS-S-920

**47.25" WIDE** FMLT-ESS-S-1200

**59" WIDE** FMLT-ESS-S-1500

- standard height = 94.5"
- standard depth = 14.17"
- straight aluminum tube frame
- rounded corners
- bungee cords for easy assembly
- sturdy feet anchor the display
- pillowcase fabric graphic
- comes with carry bag



## FORMULATE ESSENTIAL BANNER – CURVED

**23.5" WIDE** FMLT-ESS-C-600

**36" WIDE** FMLT-ESS-C-920

**47.25" WIDE** FMLT-ESS-C-1200

**59" WIDE** FMLT-ESS-C-1500

- standard height = 94.5"
- standard depth = 15.75"
- curved aluminum tube frame
- rounded corners
- bungee cords for easy assembly
- sturdy feet anchor the display
- pillowcase fabric graphic
- comes with carry bag



# FORMULATE® ESSENTIAL BANNER DISPLAYS



## ENTICE FMLT-ESS-ENTICE-01

31.5" w x 89.5" h x 17.88" d  
Entice is a double sided tension fabric display stand that features a small, clear acrylic shelf. Entice is offered with a curved or sloped top and allows you to dress up any space with your own graphic. Entice comes with a canvas over-the-shoulder carry bag. Shelf spans 34.5" w and is 6.25" deep, and can hold a maximum of 15 lbs.



## COBRA FMLT-ESS-COBRA

36.25" w x 89.5" h x 34.5" d  
The Cobra is a single or double sided fabric banner stand. Simply connect the basic lightweight aluminum tube frame, slip the fabric graphic on and you have a sleek serpentine-curved banner stand in minutes. Includes a canvas carry bag.



*bungee corded poles  
allow for simple assembly\**



*easy to apply  
pillowcase fabric  
graphics*

\*select Formulate banners feature bungee cords

**MODULATE™**  
MIX & MATCH



Modulate™ is a modular, fabric structure system that allows for hundreds of customized configurations of banners and backwalls that result in imaginative and original inline displays. Aluminum tube frames, a universal foot and clamp system are coupled with zipper pillowcase fabric graphics to create versatile, eye-catching displays.

## DESIGN YOUR OWN COMBINATIONS

CHOOSE FROM 11 FRAME SHAPES & COMBINE TO CREATE A TAILORED INLINE DISPLAY



1



2



3



4

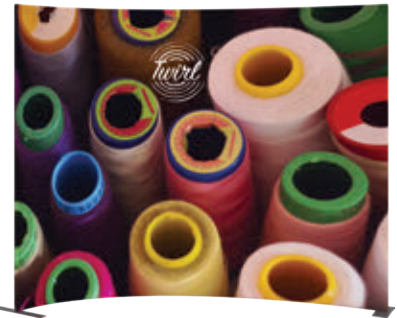

5



6



7



8



9



10

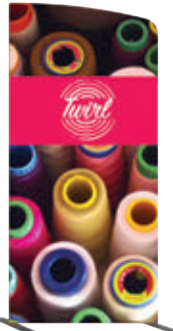

11

### MAKE UNIQUELY YOURS

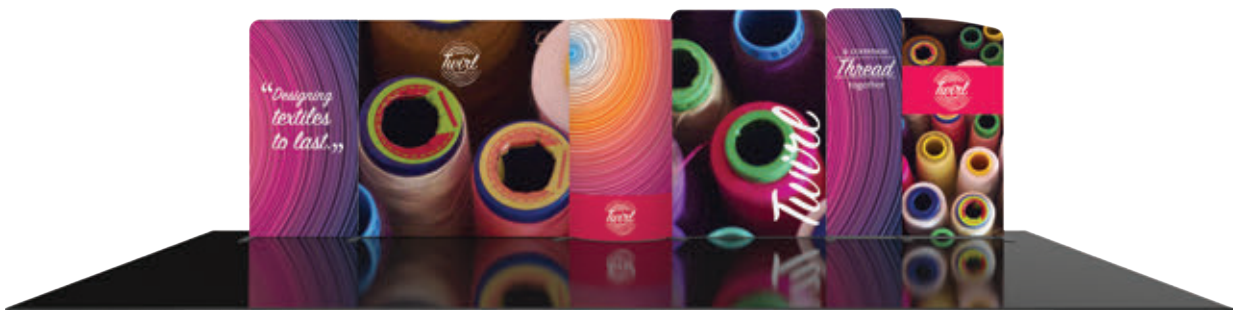

DESIGN  
EXAMPLE

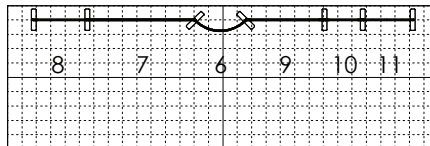

Modulate displays come with a carry bag and a lifetime limited hardware warranty.

**NEW**

# MODULATE™ RECONFIGURABLE KITS

If you have a tradeshow schedule where you have multiple size spaces to plan for, Modulate is the perfect exhibit system. Modulate™ pre-defined 30' inline kits can reconfigure easily into smaller exhibit sizes with no extra parts or packaging!  
**Maximize your value in a versatile, reconfigurable system.**

## SNAP TOGETHER AND RECONFIGURE

### CONVERT A 30' INLINE



MOD-30-01

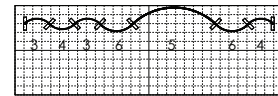

### INTO A 20' INLINE

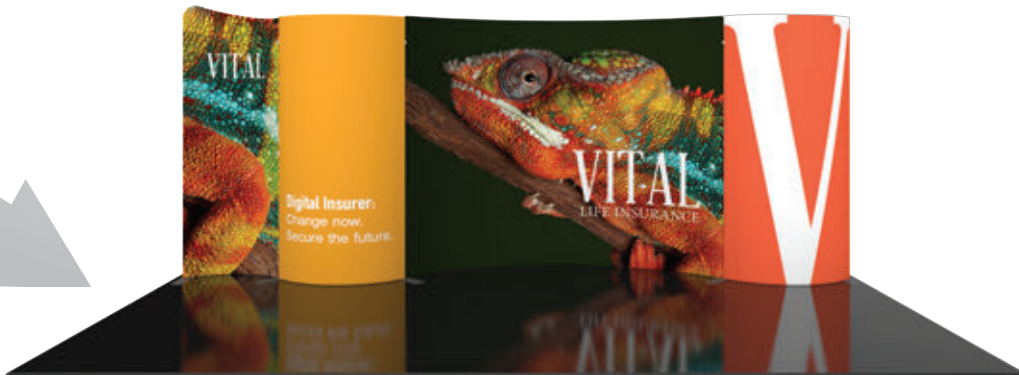

MOD-20-01

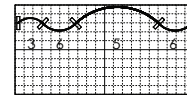

### OR TWO 10' INLINE DISPLAYS



MOD-10-01



MOD-10-02



*see p. 88-93  
for more details*



Modulate displays come with a carry bag and a lifetime limited hardware warranty.

# VECTOR FRAME™ FABRIC LIGHT BOXES

Vector Frame™ fabric light boxes feature durable 4" aluminum extrusion frames, push-fit INTENSITY backlit fabric graphics and LED edge lighting. Single and double sided graphic options are available.



LED lights come adhered to the frame, making set-up as simple as:

1. assembling the frame
2. applying the push-fit graphics
3. plugging in the electrical cord!

04 Rectangle  
**VF-LB-R-04**  
48.11" w x 94.74" h x 19.69" d  
comes in OCH case



## LIGHT BOXES



01 Rectangle  
**VF-LB-R-01**  
36.3" w x 47.49" h x 19.69" d  
comes in 1 OCE case



02 Rectangle  
**VF-LB-R-02**  
36.3" w x 71.12" h x 19.69" d  
comes in 1 OCH case



03 Rectangle  
**VF-LB-R-03**  
48.11" w x 71.12" h x 19.69" d  
comes in 1 OCH case



05 Rectangle  
**VF-LB-R-05**  
118.99" w x 94.74" h x 19.69" d  
comes in 1 OCH case



01 Square  
**VF-LB-S-01**  
36.3" w x 35.68" h x 19.69" d  
comes in 1 OCE case



02 Square  
**VF-LB-S-02**  
48.11" w x 47.49" h x 19.69" d  
comes in 1 OCE case



03 Square  
**VF-LB-S-03**  
71.73" w x 71.12" h x 19.69" d  
comes in 1 OCH case



04 Square  
**VF-LB-S-04**  
95.35" w x 94.74" h x 19.69" d  
comes in 1 OCH case



All Vector Frame displays are made in North America and have a limited lifetime hardware warranty.



# VECTOR FRAME™ FABRIC BANNERS

Vector Frame™ fabric banners combine aluminum extrusion frames with push-fit fabric graphics to create a versatile banner, backwall, hanging art or display. Vector Frame banners can be used to display messaging or art in a corporate environment or at a tradeshow and feature a 2" aluminum extrusion frame and single or double sided graphics.



05 Rectangle  
**VF-R-05**  
118.98" w x 94.74" h x 19.69" d  
comes in 1 OCL case



*easy to apply  
push-fit fabric graphics*

*fits perfect in a 10' space!*

## BANNERS



01 Rectangle  
**VF-R-01**  
36.3" w x 47.49" h x 19.69" d  
comes in 1 OCL case



02 Rectangle  
**VF-R-02**  
36.3" w x 71.12" h x 19.69" d  
comes in 1 OCS case



03 Rectangle  
**VF-R-03**  
48.11" w x 71.12" h x 19.69" d  
comes in 1 OCL case



04 Rectangle  
**VF-R-04**  
48.11" w x 94.74" h x 19.69" d  
comes in 1 OCL case



01 Square  
**VF-S-01**  
36.3" w x 35.68" h x 19.69" d  
comes in 1 OCS case



02 Square  
**VF-S-02**  
48.11" w x 47.49" h x 19.69" d  
comes in 1 OCL case



03 Square  
**VF-S-03**  
71.73" w x 71.12" h x 19.69" d  
comes in 1 OCS case



04 Square  
**VF-S-04**  
95.35" w x 94.74" h x 19.69" d  
comes in 1 OCL case



All Vector Frame displays are made in North America and have a limited lifetime hardware warranty.

# VECTOR FRAME™ FABRIC CURVED BANNERS

Vector Frame™ curved banners combine 2" aluminum extrusion frames with push-fit fabric graphics to create a versatile single and double sided banner, backwall or interior display. Use as a concave or convex shape.



01 Curved Rectangle  
**VF-CR-01**  
39.33" w x 94.74" h x 19.69" d  
comes in 1 OCL case



02 Curved Rectangle  
**VF-CR-02**  
56.75" w x 94.74" h x 19.49" d  
comes in 1 OCL case



03 Curved Rectangle  
**VF-CR-03**  
68" w x 94.74" h x 18.75" d  
comes in 1 OCL case

# VECTOR FRAME MONITOR KIOSKS

Vector Frame™ Monitor Kiosks are a sleek, stylish way to display media at any tradeshow, event, in a retail or corporate space. The kiosks feature push-fit fabric graphics, easy-to-assemble 4" extrusion frames, your choice of single or double sided graphics and one or two monitor mounts (monitors not included). These kiosks complement the Vector Frame line of banners, backwalls, exhibit kits and counters.



01 Monitor Kiosk  
**VF-MK-01-SS**  
**VF-MK-01-DS**  
36.3" w x 94.74" h x 19.69" d  
comes in 1 OCH case  
supports 32-55" monitor\*;  
max weight = 80 lbs each

front with graphic & monitor mount\*



back with graphic



back with graphic & monitor mount\*



top view  
one monitor mount



02 Monitor Kiosk  
**VF-MK-02-SS**  
**VF-MK-02-DS**  
48.11" w x 94.74" h x 19.69" d  
comes in 1 OCH case  
supports 32-55" monitor\*;  
max weight = 80 lbs each

front with graphic & monitor mount\*



back with graphic



back with graphic & monitor mount\*



top view  
two monitor mounts

\*Monitors not included.

# VECTOR FRAME™ EDGE POSTER FRAMES

Vector Frame™ Edge fabric poster displays combine durable, slim 3/4" lightweight aluminum extrusion frames and easy-to-apply push-fit fabric graphics. Custom frame sizes are available.



### Square Sizes:

- VFE-S-01: 11.8" w x 11.8" h
- VFE-S-02: 23.62" w x 23.62" h
- VFE-S-03: 35.43" w x 35.43" h
- VFE-S-04: 47.24" w x 47.24" h
- VFE-S-05: 59.06" w x 59.06" h

### Rectangle Sizes:

- VFE-R-01: 11.8" w x 23.62" h
- VFE-R-02: 11.8" w x 35.43" h
- VFE-R-03: 23.62" w x 35.43" h
- VFE-R-04: 23.62" w x 47.24" h



### Features Include:

- slim, lightweight 3/4" aluminum frame
- easy-to-apply push-fit fabric graphic
- direct to wall mounting
- custom frame sizes available



*use as posters in  
a retail setting*



*use as  
directional signs*



*use as advertisements*



# OUTDOOR DISPLAYS



## CAPTURE. YOUR. ATTENTION.

One-stop-shop for all your outdoor signage needs • The Zoom™ line of outdoor flags span heights of 8' to over 16' • Great for outdoor sporting events and arenas, concerts, festivals or to draw attention to any storefront • Strong, solid, stable, wind-resistant, durable • Graphics are long-lasting and can endure exposure to outdoor elements

## OUTDOOR DISPLAYS

Outdoor events such as festivals, street fairs, arts and craft shows and sporting events are perfect opportunities for promotional tents and signage to clearly display your company name, brand and message to attract visitors and buyers. Choose from off-the-shelf tents and related accessories, flags and portable billboards to make your event a success.



Shown above are the Zoom™ 10' PopUp Tent frame with printed canopy and additional accessories – full backwall and half wall hardware and graphics. Also featured is the Tubular 10' Dome Tent, Monsoon portable billboard, Zoom Edge Large flag and 6' printed table throw.



ZOOM™ 10' POPUP TENT

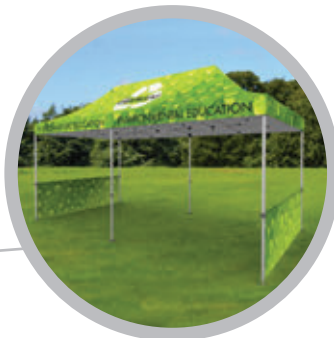

ZOOM™ 20' POPUP TENT



TUBULAR 10' DOME TENT

## ZOOM™ POPUP TENTS



- 10' opens to base size of 9.6' x 9.6'; 20' opens to base size of 9.6' x 19.6'
- rust-resistant aluminum extrusion frame is completely self-contained with no loose parts
- canopies offered in 5 standard colors and can also be custom printed; water & UV-resistant
- hardware only kit includes frame, stakes, guy lines and rolling carrying bag
- canopy kits include canopy (standard colors or custom printed), hardware frame, stakes, guy lines and rolling carrying bag
- sidewalls and rail skirts sold separately

### ZOOM™ 10' POPUP TENT

hardware only kit: **TNT-3MX3M-FRM-HEX**  
 kit with canopy: **TNT-3MX3M-HEX-(COLOR OR G)**  
 stock canopy only: **TNT-3MX3M-CAN-(COLOR)**  
 printed canopy only: **TNT-3MX3M-CAN-G**  
 full wall kits: **TNT-3MX3M-FLL-WLL-(COLOR OR G)**  
 half wall kits: **TNT-3MX3M-HLF-WLL-K-(COLOR OR G)**

*digitally printed canopies, sidewalls & backwalls available*

*available with stock canopy tops and walls*



*10'w & 20'w tents come in roller bag*



### INFLATABLE 10' DOME TENT TNT-INF-3MX3M



- base size of 9.84' x 9.84'
- sturdy vinyl body inflates easily with air compressor in less than 10 minutes
- printed canopies & sidewalls are water and UV-resistant
- hardware only kit includes inflatable frame, air pump, guy lines, stakes and carry bag
- canopy kits include canopy, inflatable frame, air pump, guy lines, stakes and carry bag
- zipper-attached printed sidewalls sold separately
- folds compactly into a carry bag



*air pump included*



All Outdoor products have a one year limited hardware warranty and are eco-friendly.



## ZOOM™ 20' POPUP TENT

hardware only kit: **TNT-3MX6M-FRM-HEX**  
 kit with canopy: **TNT-3MX6M-HEX-(COLOR OR G)**  
 stock canopy only: **TNT-3MX6M-CAN-(COLOR)**  
 printed canopy only: **TNT-3MX6M-CAN-G**  
 full wall kits: **TNT-3MX6M-FLL-WLL-(COLOR OR G)**  
 half wall kits: **TNT-3MX6M-HLF-WLL-K-(COLOR OR G)**

\*shown with optional sidewall, backwall and Zoom™ Tent Flag

Zoom™ Tent Flag attaches to any upright pole of the Zoom Popup Tent  
**TNT-ZOOM-ACC**



## TUBULAR 10' DOME TENT

### TNT-TDT-10



- base size of 9.6' x 9.6'
- aluminum tubular frame assembles quickly and easily with use of snap button connectors
- custom printed canopy is water and UV-resistant
- hardware kit includes frame
- canopy kits include canopy, frame and cases
- easily disassembles and stores compactly in two OCE hard shell expandable cases



All Outdoor products have a one year limited hardware warranty and are eco-friendly.

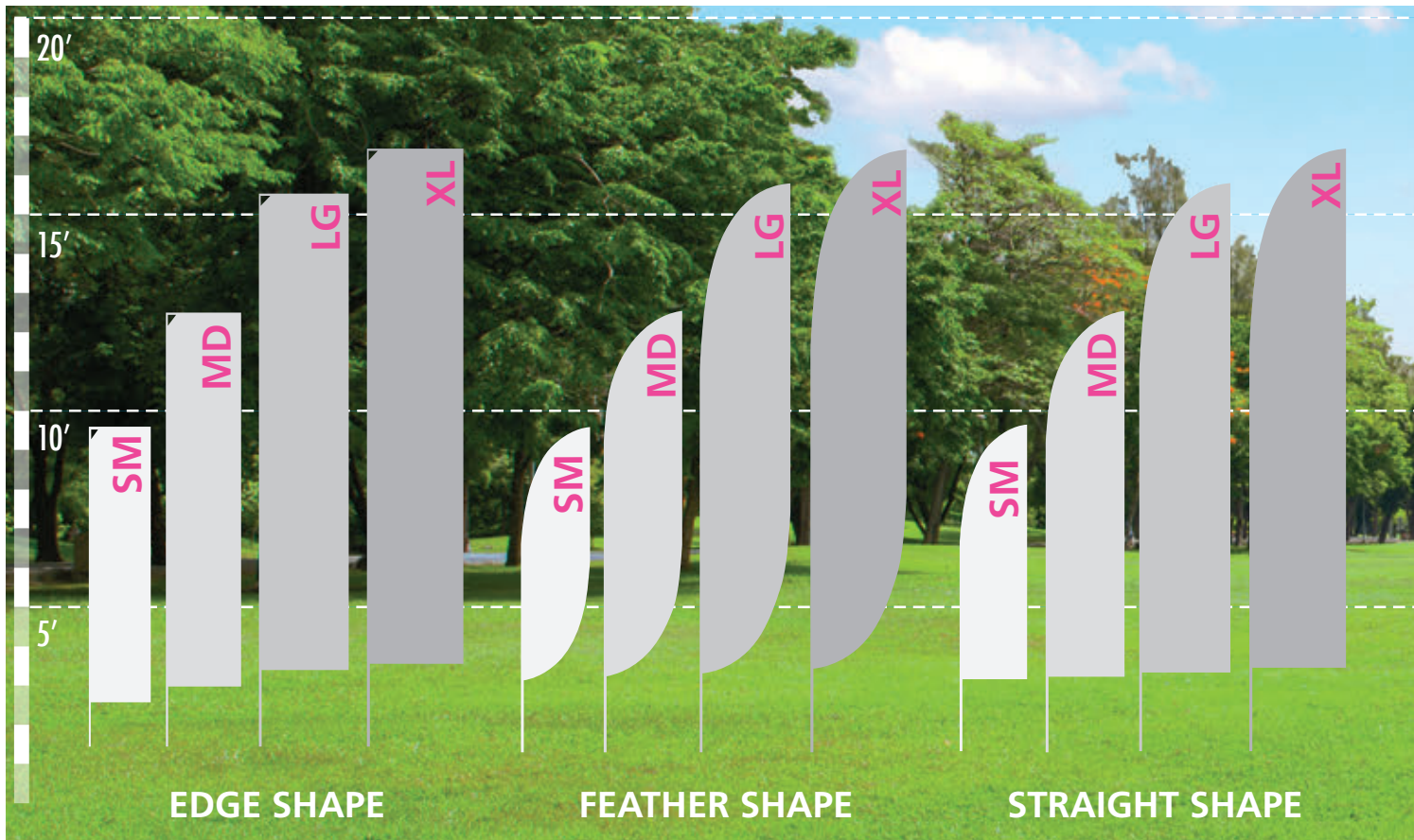

## ZOOM™ FLEX FLAGS

- can be used indoors or outdoors
- comes in four shapes: teardrop, feather, straight & edge
- graphic rotates in wind
- water ring base support adds stability to cross base (optional upgrades)
- graphic printed on flag material
- double sided graphic available
- includes ground stake only



shown with optional cross base & water ring base support



All Outdoor products have a one year limited hardware warranty.



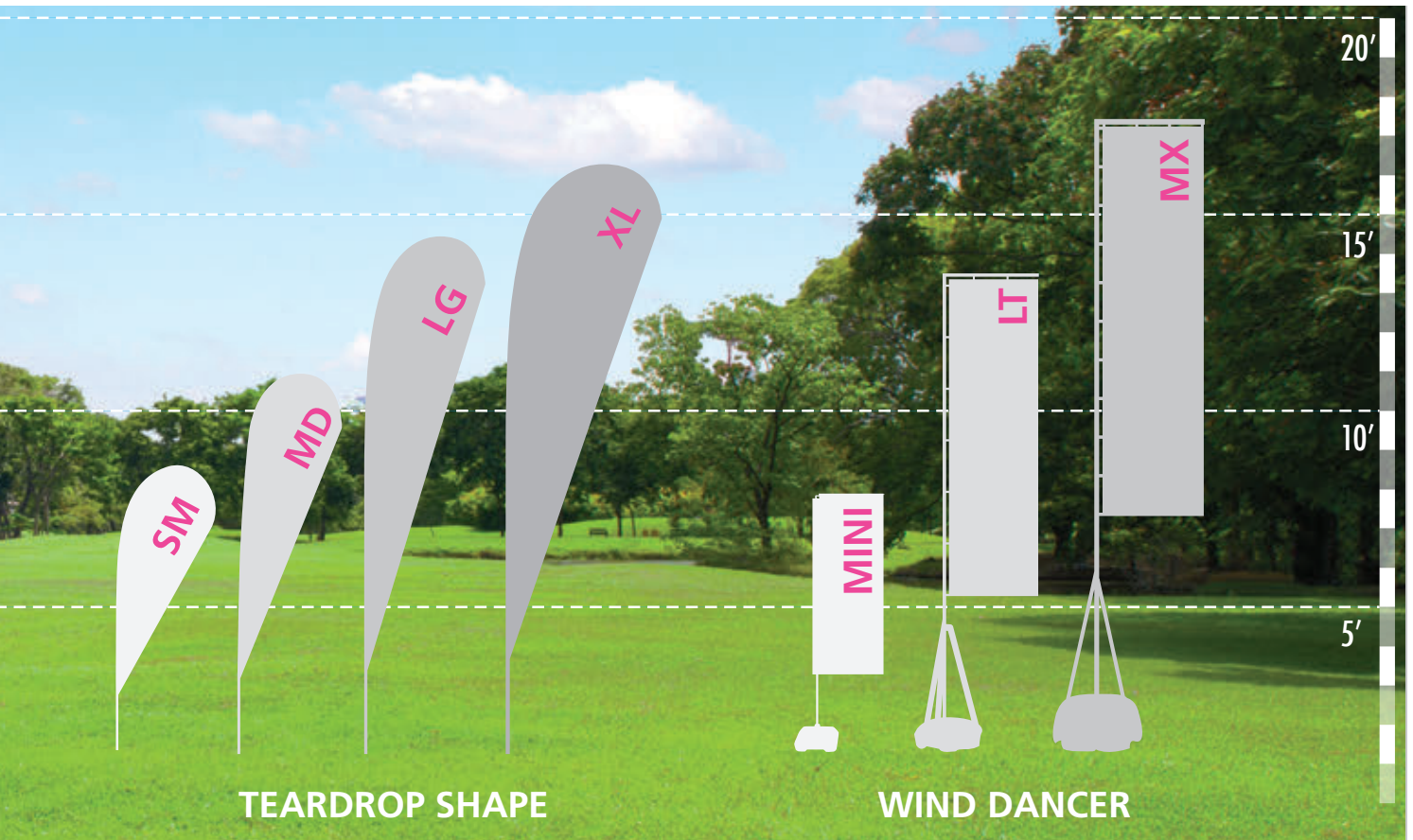

\*Not to exact scale, refer to graphic template

## ZOOM™ BASE OPTIONS **NEW**

<b>STANDALONE BASES</b>				<b>SAND &amp; TURF</b>			<b>DRIVE OVER</b>		<b>BASE SUPPORT</b>	
	cross base ZOOM-FLX-CB	square steel base ZOOM-FLX-SQ	fillable ground base ZOOM-FLX-FB		auger base ZOOM-FLX-AGR	ground stake (included) ZOOM-FLX-STK		drive-over base ZOOM-FLX-DO		water ring base support ZOOM-FLX-WR



OUTDOOR DISPLAYS



All Outdoor products have a one year limited hardware warranty.

## OUTDOOR SIGNAGE

Outdoor signage, flags and displays are great for outdoor sporting events and arenas, concerts, festivals and more. Outdoor display products are strong, solid, stable, wind-resistant and durable. Graphics are long-lasting and can endure exposure to outdoor elements.



- approximate max height = 8.5'



### WIND DANCER MINI WIND-MIN

- adjustable graphic height = up to 6'
- economy outdoor flag
- plastic pole, easy push-fit assembly
- hollow plastic base can be filled with water or sand
- double sided graphic available



- approximate max height = 13.5'



### WIND DANCER LT WIND-LT

- adjustable graphic height = up to 8'8"
- hollow base can be filled with either water or sand as weighing agent
- double sided graphic available
- optional carry bag



- approximate max height = 17.5'



### WIND DANCER WIND-MX

- adjustable graphic height = up to 12'
- flag is approximately 43" wide
- hollow base can be filled with either water or sand as weighing agent
- double sided graphic available
- optional carry bag



### ATLAS ATLAS

- outdoor sign holder
- use as many as you need to hold a large rigid graphic .4"-.5" thick
- quick set-up, easy storage
- hollow plastic base can be filled with water or sand



### WHIRLWIND WHRL-WND-2

- 31.1" w x 45.7" h x 19.7" d
- front-loading snap frames constructed from aluminum & powder-coated steel
- single or double sided
- includes clear lens cover
- dual-spring design flexes to withstand wind gusts
- compact durable base can be filled with water or sand for extra stability
- integrated wheel set



### CAFÉ BARRIER CB-K-1500 CB-EXT-K-1500

- indoor/outdoor modular display
- stylish way to define areas or dictate traffic flow in or outside restaurants, bars, retail establishments, airports, museums, casinos and at tradeshow
- visual graphic area = approx. 53.25" w x 30.5" h
- heavy-duty stainless steel posts, base and 59" w rails
- unit kit, extension kit and individual components available



## INFLATABLE COLUMNS

INF-COL-S: 18.5"dia. x 53.75"h

INF-COL-M: 18.5"dia. x 92.75"h

INF-COL-L: 18.5"dia. x 115.25"h

- freestanding inflatable column
- indoor/outdoor use
- hollow plastic base can be filled with water or sand
- custom printed canvas graphics are waterproof
- stays inflated without air pump
- pump and ground stakes sold separately
- tabs with grommets for optional stake usage



## PARKWAY

single span: PKWY-S-SPN-3

double span: PKWY-D-SPN-3

- single span = 32" w x 60" h
- double span = 67" w x 60" h
- withstands winds up to 38MPH
- single or double span street pole banner



## ZOOM™ BACKPACK FLAGS

ZOOM-BKPK

- can be used with four different flag types/shapes
  - teardrop, feather, straight and X-banner style
- poles and rods that support every style flag fit within the backpack
- reinforced straps, adjustable belt and padding all help with stability and comfort
- reinforced straps and flag mounting system
- mesh side-pockets and a zipped compartment add more storage
- bag made from coated nylon



X-BANNER

FEATHER

TEARDROP

STRAIGHT

# OUTDOOR SIGNAGE



Outdoor signage, flags and displays are great for outdoor sporting events and arenas, concerts, festivals or to draw attention to any storefront. Outdoor display products are strong, solid, stable, wind-resistant and durable. Graphics are long-lasting and can endure exposure to outdoor elements.

## SPRING 5 SB-5



- standard graphic height = 70.75"
- 31.5" wide
- indoor or outdoor use
- single or double sided
- hollow base can be filled with either water or sand as weighing agent
- easy grommet graphic attachment
- tension pole system



## BLIZZARD BLZD



- max width x min height: 40"w x 49.5"h
- min width x max height: 23.5"w x 80"h
- max width x max height: 40"w x 74.5"h
- min width x min height: 23.5"w x 49.5"h
- outdoor banner stand
- hollow base can be filled with either water or sand as weighing agent
- easy grommet graphic attachment



## THUNDER THUNDER



- visual graphic area = approx. 33.5"w x 79.7"h
- double sided outdoor retractable banner stand
- large twist-lock feet
- stakes included to secure to ground
- snap-top graphic rail
- 3-piece bungee pole



## MONSOON MONSN-2



- visual graphic area = approx. 92.125"w x 32"h
- semi-portable single or double sided billboard
- easy grommet graphic attachment
- includes ground stakes & bungee rope





### ROUND PROMOTIONAL UMBRELLA

- printed promotional umbrella – 8'5" dia. canopy, water resistant
- canopy also available in off-white, green and burgundy stock colors
- can be used for commercial or residential use
- steel poles and arms are white
- overall height with umbrella = 94"
- carry bag included



### STOWAWAY

**STOW-S:** 53"w x 27"h x 23.25"d  
**STOW-M:** 81.75"w x 34.25"h x 23.75"d

- high visual impact display stand
- indoor/outdoor use
- extremely lightweight
- includes carry bag & 4 ground stakes
- no tools required
- custom printed graphics
- available in three sizes



ground stakes included

### SQUARE PROMOTIONAL UMBRELLA

- printed promotional umbrella, water-resistant
- can be used for commercial or residential use
- white frame
- overall height with umbrella = 109"
- carry bag included



base sold separately

# TABLE THROWS & RUNNERS



## MEET. AND. GREET.

One-stop-shop for the fastest table throws and runners • Can be used in many ways; perfect to display your messaging in any tradeshow or event – indoor or outdoor • Printed, imprinted, convertible, stretch and fitted options to choose from • Sizes of 4', 6', 8', full and economy • Choose from 7 fabric colors and 21 vinyl colors

## PRINTED TABLE THROW

- 4' full: TBL-T-4-F
- 4' economy: TBL-T-4-E
- 6' full: TBL-T-6-F
- 6' economy: TBL-T-6-E
- 8' full: TBL-T-8-F
- 8' economy: TBL-T-8-E

- complete your presentation with a premium printed table throw
- lends a polished appearance to any display
- maximize your advertising with additional space to display your message



carry bags available,  
fits 4 or 6 table throws  
**TBL-THRW-BG**  
**TBL-THRW-BG2**

shown with  
Horizon Standard  
tabletop folding  
panel display  
(p. 68)



## CONVERTIBLE TABLE THROW

- convertible full: TBL-T-FC
- convertible economy: TBL-T-EC

- printed throw converts quickly and easily to fit both a 6' and 8' table
- Velcro tabs make conversion simple



*shown as 8' convertible table throw*

## TABLE RUNNERS

- 24" full: TBL-R-24-F
- 24" economy: TBL-R-24-E
- 30" full: TBL-R-30-F
- 30" economy: TBL-R-30-E
- 36" full: TBL-R-36-F
- 36" economy: TBL-R-36-E
- 60" full: TBL-R-60-F
- 60" economy: TBL-R-60-E

- accent your solid colored table throw with a full color printed runner
- available in four widths



All table throws and runners come with a graphic limited warranty of 6 months and are made in North America.

## FITTED TABLE THROW

4' full: TBL-FT-4-F

6' full: TBL-FT-6-F

8' full: TBL-FT-8-F

- form fitted to fit 4', 6' & 8' tabletops
- optional carry bag available
- fitted fabric dye-sublimated printed table throw lends a polished look to any display



## STRETCH TABLE THROW

4' full: TBL-SW-4-F

6' full: TBL-SW-6-F

8' full: TBL-SW-8-F

- tailored to fit 4', 6' & 8' tables top to bottom
- optional carry bag available
- stretch fabric dye-sublimated printed table throw lends a stylish look to any display
- zipper in the back provides access to underneath the table



## ROUND TABLE THROWS

30" dia., 30" h draped, fitted & stretch options

30" dia., 42" h draped, fitted & stretch options

48" dia., 30" h draped & fitted options

60" dia., 30" h draped & fitted options

- tailored to fit round tables
- printed on premium dye-sublimated fabric
- all options lend a stylish and polished look to any event



All table throws and runners come with a graphic limited warranty of 6 months and are made in North America.



# IMPRINTED TABLE THROW

- 6' full
- 6' economy
- 8' full
- 8' economy

- 7 standard table throw colors
- 21 standard vinyl options
- maximum logo size = 60" w x 21.5" h (see template for details)
- must be simple vector artwork, no complex logos or gradients
- maximum two vinyl colors per logo imprint
- referenced Pantone colors are not exact
- vinyl is heat transferred



full table throw shown in red fabric with white and sky blue imprinted vinyl



economy table throw leaves back of table exposed for easy access to storage

## FULL TABLE THROW

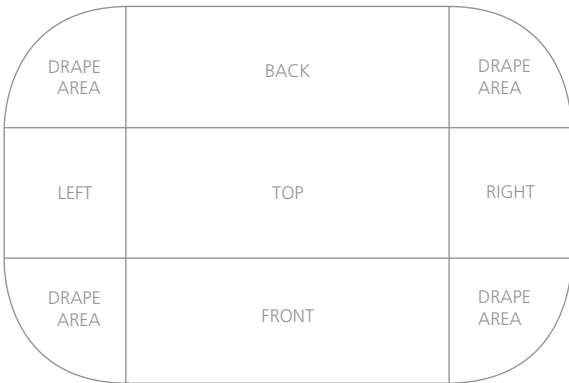

## ECONOMY TABLE THROW

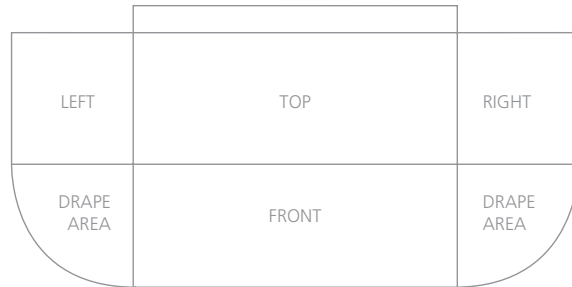

## FABRIC COLORS

red Pantone® 201C	royal blue Pantone® 661C	gray Pantone® 422C	hunter green Pantone® 350C
navy Pantone® 282C	black	white	

## VINYL COLORS

black	white	blue Pantone® 293C	hot pink Pantone® Process Magenta C	royal purple Pantone® 2755C	red Pantone® 200C	vegas gold Pantone® 467C
kelly green Pantone® 342C	sky blue Pantone® 283C	lemon yellow Pantone® 101C	medium yellow Pantone® 123C	burnt orange Pantone® 167C	orange Pantone® 021C	gray Pantone® Cool Gray 9C
navy Pantone® 2766C	apple green Pantone® 368C	forest green Pantone® 350C	vanilla cream Pantone® 7499C	sapphire blue Pantone® 2925C	brown Pantone® 1545C	teal Pantone® 315C



All table throws and runners come with a graphic limited warranty of 6 months and are made in North America.

# HOPUP™ TENSION FABRIC



## FAST. DYNAMIC. FABRIC.

Combining style and speed, the attached fabric graphic makes the Hopup™ the fastest display on the market • The Hopup is one of the most dynamic and popular large format graphic displays due to its maximum impact with minimal effort • Lightweight and highly portable • Easy to set up and packs away as fast as it sets up



# HOPUP™ BACKWALLS

The Hopup™ is one of the most dynamic and popular large format graphic displays due to its maximum impact with minimal effort. Hopup Tension Fabric Displays come in a variety of sizes and are offered in straight and curved frames. Hopups require no tools for assembly, are lightweight and highly portable and they pack away as easy as they set up! LED lighting makes the Hopup glow and stand out even more.



comes with a wheeled carry bag; optional hard cases available (p. 84)



all sizes available with or without endcaps

# STRAIGHT HOPUP™ CONFIGURATIONS



2½' tabletop  
footprint dimensions:  
31" w x 31" h x 12.25" d  
**HOP-1X1FG-S**



5' tabletop  
footprint dimensions:  
60.5" w x 31" h x 12.25" d  
**HOP-2X1FG-S**



5' tabletop  
footprint dimensions:  
60.5" w x 60.5" h x 12.25" d  
**HOP-2X2FG-S**



7½' tabletop  
footprint dimensions:  
89.5" w x 60.5" h x 12.25" d  
**HOP-3X2FG-S**



2½' full height standard display  
footprint dimensions:  
31" w x 90" h x 29" d  
**HOP-1X3FG-S**



5' full height standard display  
footprint dimensions:  
60.5" w x 90" h x 29" d  
**HOP-2X3FG-S**



7½' full height standard display  
footprint dimensions:  
89.5" w x 90" h x 29" d  
**HOP-3X3FG-S**



10' full height standard display  
footprint dimensions:  
119" w x 90" h x 29" d  
**HOP-4X3FG-S**



12¼' full height standard display  
footprint dimensions:  
147.25" w x 90" h x 29" d  
**HOP-5X3FG-S**

## HOPUP™ COUNTER HOP-CT-2

- collapsible display counter
- easy-to-assemble
- includes clear internal shelf
- 41.75" w x 39.69" h x 14.25" d
- top available in four laminate finish options (p. 74)



## CURVED HOPUP™ CONFIGURATIONS



5½' tabletop  
footprint dimensions:  
64" w x 60.5" h x 12.25" d  
**HOP-2X2FGE-C**



5½' tabletop  
footprint dimensions:  
64" w x 31" h x 12.25" d  
**HOP-2X1FGE-C**



7½' tabletop  
footprint dimensions:  
92" w x 60.5" h x 12.25" d  
**HOP-3X2FGE-C**



5½' full height standard display  
footprint dimensions:  
64" w x 89.5" h x 12.25" d  
**HOP-2X3FGE-C**



7½' full height standard display  
footprint dimensions:  
92" w x 89.5" h x 12.25" d  
**HOP-3X3FGE-C**



10' full height standard display  
footprint dimensions:  
116.25" w x 89.5" h x 12.25" d  
**HOP-4X3FGE-C**



11½' full height standard display  
footprint dimensions:  
136.5" w x 89.5" h x 12.25" d  
**HOP-5X3FGE-C**

## BACKLIT HOPUP™

- lightweight, heavy-duty silver frame
- supports an integrated full fitted fabric graphic mural with end caps only
- available in 5', 7 ½' or 10' sizes (curved only)
- LED lights include one year limited warranty
- comes in an OCX molded case

**HOP-BL2X2-FGE-C**  
**HOP-BL3X3-FGE-C**  
**HOP-BL4X3-FGE-C**



All Hopup frames are eco-friendly, come with a rolling carry case, and have a limited lifetime warranty.

# HOPUP™ BACKWALL DIMENSIONS

## COMPLETE SYSTEMS & ACCESSORY KITS



The Hopup™ is one of the most dynamic and popular large format graphic displays due to its maximum impact with minimal effort. Hopup Backwall Dimensions add style, flare and function to any 7 ½' or 10' Hopup straight display. Easily accessorize your Hopup with monitor mounts, counters, tables and more. Purchase as a complete kit or as an accessory for your existing straight Hopup. Dimensional elements can be placed in the middle, left or right sides of the display.

### DIMENSION KIT 01

#### HOP-DIM-01-3X3FG-S

- 7 ½' full height straight backwall
- 2 stand-off rigid graphic accents with literature holders
- monitor\* mount supports 23" monitor, max weight = 30 lbs
- 2 Lumina 200 lights



ACCESSORY 01  
HOP-DIM-01

### DIMENSION KIT 02

#### HOP-DIM-02-3X3FG-S

- 7 ½' full height straight backwall
- stand-off counter supports max 35 lbs
- counter features graphic and literature holder
- monitor\* mount supports 23" monitor, max weight = 30 lbs
- 2 Lumina 200 lights



ACCESSORY 02  
HOP-DIM-02

Hopup Dimensions counter tops are available in your choice of four thermoform finishes



silver black mahogany natural

## HOPUP™ BACKWALL DIMENSIONS COMPLETE SYSTEMS & ACCESSORY KITS

### DIMENSION KIT 03 HOP-DIM-03-4X3FGE-S

- 10' full height straight backwall
- accessory counter features:
  - monitor\* mount supports 40" monitor, max weight = 50 lbs
  - counter top holding max weight of 35 lbs
  - printed fabric graphic and literature holder
- 2 Lumina 200 lights



ACCESSORY 03  
HOP-DIM-03

### DIMENSION KIT 04 HOP-DIM-04-4X3FGE-S

- 10' full height straight backwall
- standoff counter features:
  - fabric graphic messaging area (top)
  - printed fabric graphic (bottom)
  - counter top holding max weight of 35 lbs
- 2 Lumina 200 lights



ACCESSORY 04  
HOP-DIM-04

EMBRACE™ PUSH-FIT TENSION FABRIC



# EMBRACE. THE. FRAME.

Embrace's push-fit fabric graphic hugs the collapsible frame and makes this portable display sleek and seamless • Embrace couples a lightweight, portable collapsible frame with a seamless, push-fit fabric graphic, creating a modern appearance • Simply pop up the frame, attach the channels for the graphic, then push the graphic beading and graphic into the channel and you have a sophisticated display in a matter of minutes.





# EMBRACE™ BACKWALLS

Embrace™ is one of the sleekest collapsible portable displays and it delivers style with minimal effort. Embrace Fabric Displays come in a variety of sizes and are offered with or without end caps. Embrace requires no tools for assembly, is lightweight and highly portable. Embrace features crisp, straight edges due to the simple, push-fit fabric graphic attachment.



*easy push-fit fabric graphics go into channel*



## EMBRACE™ BACKWALL

- lightweight anodized straight silver frame
- stabilizer feet on all frames 3 quads high
- simple assembly
- perimeter channel bars connect to frame and hold push-fit fabric graphic
- crisp, push-fit fabric graphic creates clean, straight edges; comes with front or fully fitted graphic (with end caps)
- rolling carry bag for most units



*channel bars for insertion of fabric graphic easily connect and slide onto collapsible frame*



*easy snap arms*

# EMBRACE™ FRONT GRAPHIC CONFIGURATIONS



2½' tabletop footprint dimensions:  
30.43" w x 30.74" h x 12.92" d  
**EMB-1X1FG-S**



5' tabletop footprint dimensions:  
59.95" w x 30.74" h x 12.92" d  
**EMB-2X1FG-S**



5' tabletop footprint dimensions:  
59.95" w x 59.95" h x 12.92" d  
**EMB-2X2FG-S**



7½' tabletop footprint dimensions:  
88.15" w x 59.59" h x 12.92" d  
**EMB-3X2FG-S**



2½' full height standard display footprint dimensions:  
31.1" w x 88.8" h x 28.94" d  
**EMB-1X3FG-S**



5' full height standard display footprint dimensions:  
59.95" w x 88.8" h x 28.94" d  
**EMB-2X3FG-S**



7½' full height standard display footprint dimensions:  
88.15" w x 88.8" h x 28.94" d  
**EMB-3X3FG-S**



10' full height standard display footprint dimensions:  
117" w x 88.8" h x 28.94" d  
**EMB-4X3FG-S**

## EMBRACE™ COUNTER

### EMB-CT

- 40.95" w x 40.23" h x 14.95" d
- collapsible display counter
- includes internal shelf
- push-fit fabric graphics
- top available in four laminate finish options



tops are available in your choice of four thermoform finishes



silver black mahogany natural



All Embrace frames are eco-friendly, come with a carry case, and have a limited lifetime warranty.

# EMBRACE™ WITH ENDCAPS CONFIGURATIONS



2½' tabletop  
footprint dimensions:  
30.43" w x 30.74" h x 12.92" d  
**EMB-1X1FGE-S**



5' tabletop  
footprint dimensions:  
59.95" w x 30.74" h x 12.92" d  
**EMB-2X1FGE-S**



5' tabletop  
footprint dimensions:  
59.95" w x 59.95" h x 12.92" d  
**EMB-2X2FGE-S**



7½' tabletop  
footprint dimensions:  
88.15" w x 59.59" h x 12.92" d  
**EMB-3X2FGE-S**



2½' full height standard display  
footprint dimensions:  
31.1" w x 88.8" h x 28.94" d  
**EMB-1X3FGE-S**



5' full height standard display  
footprint dimensions:  
59.95" w x 88.8" h x 28.94" d  
**EMB-2X3FGE-S**



7½' full height standard display  
footprint dimensions:  
88.15" w x 88.8" h x 28.94" d  
**EMB-3X3FGE-S**



10' full height standard display  
footprint dimensions:  
117" w x 88.8" h x 28.94" d  
**EMB-4X3FGE-S**



comes with a carry bag or wheeled carry bag; optional hard cases available (p. 84)



all sizes available with or without endcaps



All Embrace frames are eco-friendly, come with a carry case, and have a limited lifetime warranty.

# EMBRACE™ INLINE CONFIGURATIONS

**NEW**

Embrace™ Fabric Backwalls can be connected together easily with a simple clamp system to create 20ft and 30ft inline backwall displays. Embrace displays feature seamless, clean, crisp lines due to the push-fit fabric graphics that hug the collapsible frame. Embrace Inline Kits include your choice of either single or double-sided graphics and also the choice of front or full fitted graphics with end caps. The graphic is one, long piece!

## BUILD WIDE!

CREATE A 20' OR 30' INLINE DISPLAY IN MINUTES!



*clamps go in the middle of each quadrant to connect the walls*



*simply connect the clamp & twist the dial to tighten*



20'w x 10'h standard display  
footprint dimensions:  
236.25" w x 89.4" h x 29" d  
**EMB-8X3FG-SS/DS-1**  
**EMB-8X3FGE-SS/DS-1**  
(with end caps)

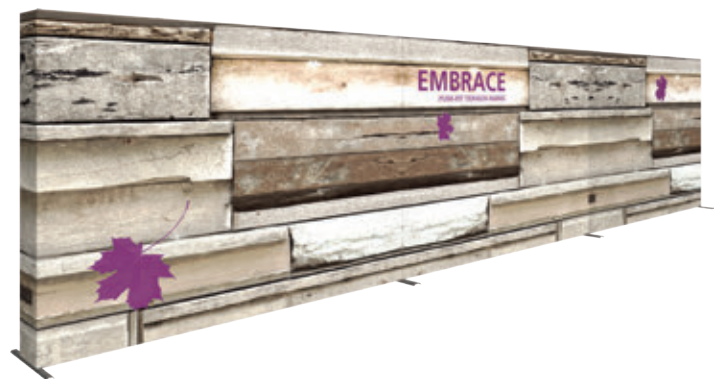

30'w x 10'h standard display  
footprint dimensions:  
353.4" w x 89.4" h x 29" d  
**EMB-12X3FG-SS/DS-1**  
**EMB-12X3FGE-SS/DS-1**  
(with end caps)



**NEW**

# EMBRACE™ INLINE CONFIGURATIONS

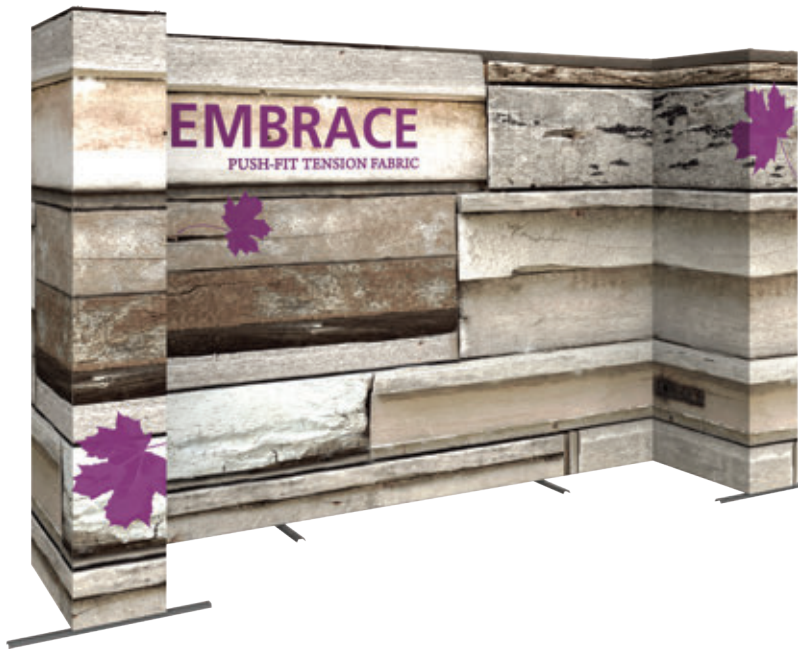

U-shape standard display  
 footprint dimensions:  
 159.6" w x 89.4" h x 51.2" d  
**EMB-U01FG-SS/DS-1**  
**EMB-U01FGE-SS/DS-1**  
 (with end caps)



**CONNECT**



**CLAMP**



**VOILA!**



L-shape standard display  
 footprint dimensions:  
 132" w x 89.4" h x 51.2" d  
**EMB-L01FG-SS/DS-1**  
**EMB-L01FGE-SS/DS-1**  
 (with end caps)



L-shape standard display  
 footprint dimensions:  
 132" w x 89.4" h x 51.2" d  
**EMB-L02FG-SS/DS-1**  
**EMB-L02FGE-SS/DS-1**  
 (with end caps)



All Embrace frames are eco-friendly, come with a carry case, and have a limited lifetime warranty.

# EMBRACE™ STACKING CONFIGURATIONS

**NEW**

Embrace™ Fabric Backwalls can be stacked one on top of another to create a near 15' tall backwall for use in tradeshow, retail environments, for events and more. With the use of a special clamping system and stabilizing feet, stacking and building high is made easy. Embrace Stacking Kits include your choice of backwall width (5ft, 7.5ft or 10ft) and your choice of either single or double-sided graphics. Graphics are individual pieces per frame.

## BUILD HIGH!

TALL BACKWALLS MADE EASY!



*stack,  
clamp,  
& repeat!*

Featured: Embrace 3X3 Quad Stack Single Sided



**STACK  
FRAMES**



**CLAMP TOP  
TO BOTTOM**



**CLAMP SIDE  
TO SIDE**



**NEW**

# EMBRACE™ STACKING CONFIGURATIONS



6.8'W x 14.8'H standard display  
footprint dimensions:  
81.5\"w x 177.25\"h x 51.2\"d  
**EMB-STCKD-2X3FG-SS/DS-1**  
**EMB-STCKD-2X3FGE-SS/DS-1**  
(with end caps)



9.2'W x 14.8'H standard display  
footprint dimensions:  
110.7\"w x 177.25\"h x 51.2\"d  
**EMB-STCKD-3X3FG-SS/DS-1**  
**EMB-STCKD-3X3FGE-SS/DS-1**  
(with end caps)



11.6'W x 14.8'H standard display  
footprint dimensions:  
138.7\"w x 177.25\"h x 51.2\"d  
**EMB-STCKD-4X3FG-SS/DS-1**  
**EMB-STCKD-4X3FGE-SS/DS-1**  
(with end caps)

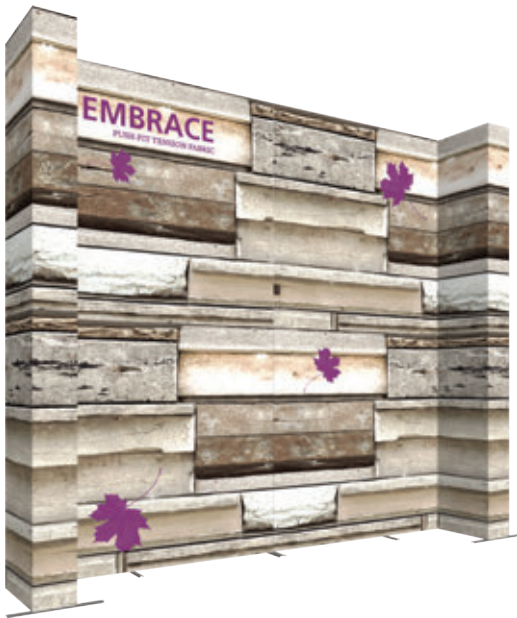

17'W x 14.8'H standard display  
footprint dimensions:  
198.25\"w x 177.25\"h x 51.2\"d  
**EMB-QD-STCKD-3X3FG-SS/DS-1**  
**EMB-QD-STCKD-3X3FGE-SS/DS-1**  
(with end caps)

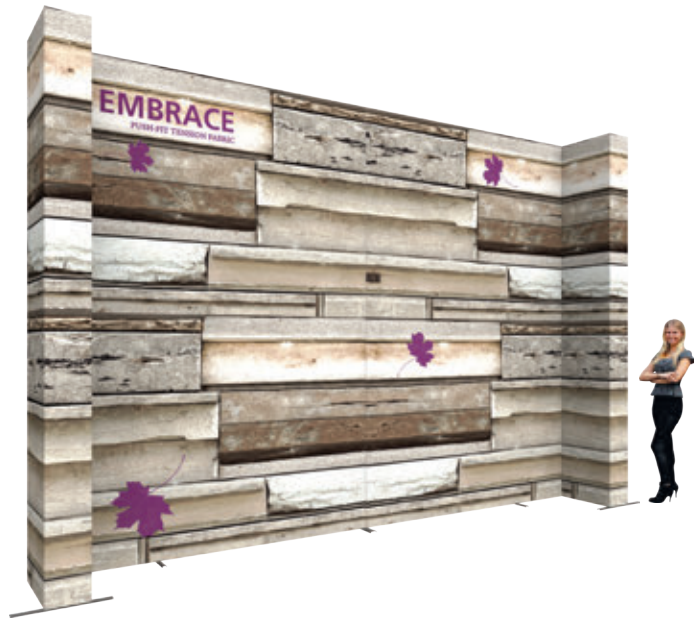

21'W x 14.8'H standard display  
footprint dimensions:  
256\"w x 177.25\"h x 51.2\"d  
**EMB-QD-STCKD-4X3FG-SS/DS-1**  
**EMB-QD-STCKD-4X3FGE-SS/DS-1**  
(with end caps)

EMBRACE | PUSH-FIT TENSION FABRIC



All Embrace frames are eco-friendly, come with a carry case, and have a limited lifetime warranty.

# XCLAIM™ FABRIC POPUP



## BOLD. VIVID. SIMPLE.

Combining dimension and simplicity • Xclaim™ couples a collapsible frame and magnetic locking arms with brilliant push-fit fabric graphics • Ease, style and the versatility Xclaim provides with simple graphic changes makes this system a top choice





## XCLAIM™ FABRIC POPUP

The Xclaim™ fabric popup system features super stretch push-fit fabric graphics that come pre-attached to the collapsible frame to create sleek, polished displays. Displays are available in a variety of sizes and configurations, and the multitude of placement possibilities of the push-fit fabric graphics are endless! Using a lightweight magnetic collapsible frame, Xclaim displays require no tools for assembly, are portable, durable and set up and pack down fast and easily. Quickly command attention with the eye-catching Xclaim display system!



**XCLAIM 3X3 KIT 03**  
XCLM-3X3-K3

# XCLAIM™ FABRIC POPUP

Xclaim™ features super stretch push-fit fabric graphics that come pre-attached to the collapsible frame to create sleek, polished displays. Displays are available in a variety of sizes and configurations, and the multitude of placement possibilities of the push-fit fabric graphics are endless! Using lightweight, magnetic collapsible frame similar to the Coyote™ Popup line, Xclaim displays are portable, durable and set up and pack down fast and easily. Quickly command attention with the eye-catching Xclaim display system!

## XCLAIM TABLETOP KITS



5' tabletop  
footprint dimensions:  
59.11" w x 59.42" h x 12.8" d  
**XCLM-2X2-K1**



5' tabletop  
footprint dimensions:  
59.11" w x 59.42" h x 12.8" d  
**XCLM-2X2-K2**



5' tabletop  
footprint dimensions:  
59.11" w x 59.42" h x 12.8" d  
**XCLM-2X2-K3**



5' tabletop  
footprint dimensions:  
59.11" w x 59.42" h x 12.8" d  
**XCLM-2X2-K4**

XCLAIM | FABRIC POPUP



All Xclaim popups are eco-friendly and have a limited lifetime warranty.

2 ½' W FULL HEIGHT KITS



2 ½' full height display  
footprint dimensions:  
30.30" w x 88.23" h x 12.8" d  
**XCLM-1X3-K1**



2 ½' full height display  
footprint dimensions:  
30.30" w x 88.23" h x 12.8" d  
**XCLM-1X3-K2**



2 ½' full height display  
footprint dimensions:  
30.30" w x 88.23" h x 12.8" d  
**XCLM-1X3-K3**



2 ½' full height display  
footprint dimensions:  
30.30" w x 88.23" h x 12.8" d  
**XCLM-1X3-K4**

5' W FULL HEIGHT KITS



5' full height display  
footprint dimensions:  
59.11" w x 88.23" h x 12.8" h  
**XCLM-2X3-K1**



5' full height display  
footprint dimensions:  
59.11" w x 88.23" h x 12.8" h  
**XCLM-2X3-K2**



push-fit  
fabric graphics



sleek hub for a  
polished look



All Xclaim popups are eco-friendly and have a limited lifetime warranty.

# XCLAIM™ FABRIC POPUP 7 ½'W FULL HEIGHT KITS



7 ½' full height display  
footprint dimensions:  
87.92" w x 88.23" h x 12.8" d  
**XCLM-3X3-K1**



7 ½' full height display  
footprint dimensions:  
87.92" w x 88.23" h x 12.8" d  
**XCLM-3X3-K2**



7 ½' full height display  
footprint dimensions:  
87.92" w x 88.23" h x 12.8" d  
**XCLM-3X3-K3**



7 ½' full height display  
footprint dimensions:  
87.92" w x 88.23" h x 12.8" d  
**XCLM-3X3-K4**



7 ½' full height display  
footprint dimensions:  
87.92" w x 88.23" h x 12.8" d  
**XCLM-3X3-K5**



7 ½' full height display  
footprint dimensions:  
87.92" w x 88.23" h x 12.8" d  
**XCLM-3X3-K6**

XCLAIM | FABRIC POPUP



All Xclaim popups are eco-friendly and have a limited lifetime warranty.

# XCLAIM™ FABRIC POPUP 10'W FULL HEIGHT KITS



10' full height display  
footprint dimensions:  
116.72" w x 88.23" h x 12.8" d  
**XCLM-4X3-K1**

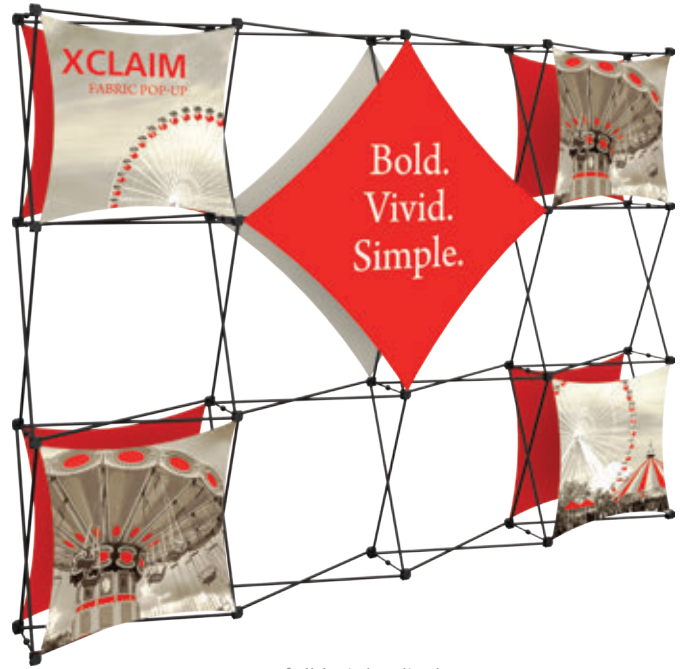

10' full height display  
footprint dimensions:  
116.72" w x 88.23" h x 12.8" d  
**XCLM-4X3-K2**



10' full height display  
footprint dimensions:  
116.72" w x 88.23" h x 12.8" d  
**XCLM-4X3-K3**



sleek hub for a  
polished look



push-fit  
fabric graphics



Add optional shelves, available  
in four color options  
**XCLM-SHLF-K**



All Xclaim popups are eco-friendly  
and have a limited lifetime warranty.

# XCLAIM™ FABRIC POPUP 10'W FULL HEIGHT KITS

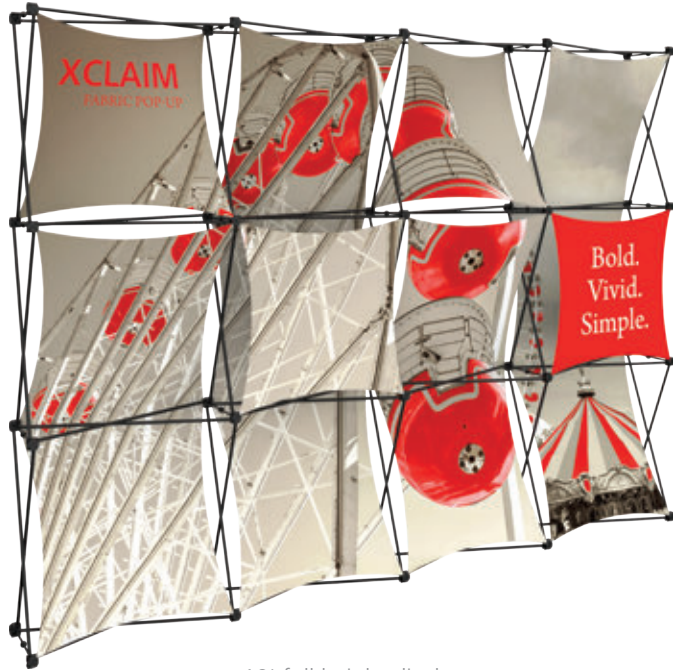

10' full height display  
footprint dimensions:  
116.72" w x 88.23" h x 12.8" d  
**XCLM-4X3-K4**



10' full height display  
footprint dimensions:  
116.72" w x 88.23" h x 12.8" d  
**XCLM-4X3-K5**



10' full height display  
footprint dimensions:  
116.72" w x 88.23" h x 12.8" d  
**XCLM-4X3-K6**



sleek hub for a  
polished look



push-fit  
fabric graphics



Add optional shelves, available  
in four color options  
**XCLM-SHLF-K**



# XCLAIM™ FABRIC POPUP

## 7'W KITS

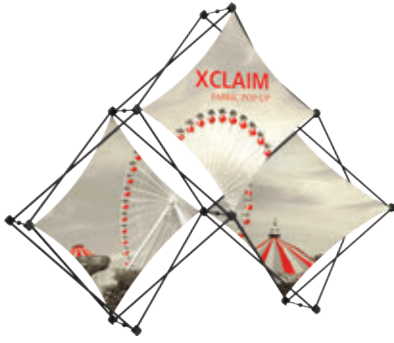

7' display  
footprint dimensions:  
83.51" w x 63.14" h x 12.8" d  
**XCLM-3QP-K1**

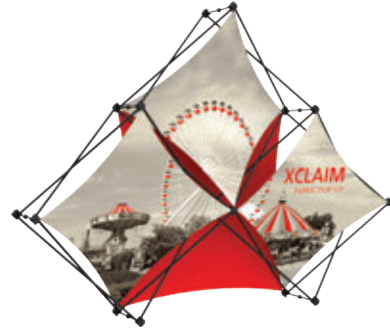

7' display  
footprint dimensions:  
83.51" w x 63.14" h x 12.8" d  
**XCLM-3QP-K2**

## 10'W KITS

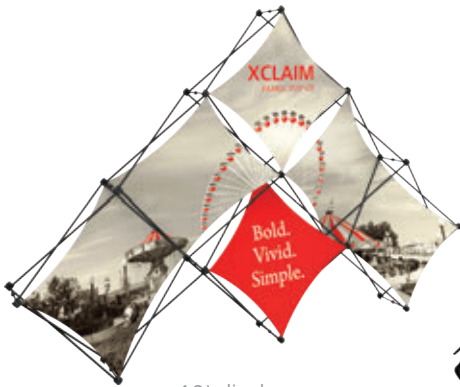

10' display  
footprint dimensions:  
124.25" w x 83.51" h x 12.8" d  
**XCLM-6QP-K1**



10' display  
footprint dimensions:  
124.25" w x 83.51" h x 12.8" d  
**XCLM-6QP-K2**

## 14'W FULL HEIGHT KITS



14' full height display  
footprint dimensions:  
164.99" w x 103.88" h x 12.8" d  
**XCLM-10QP-K1**

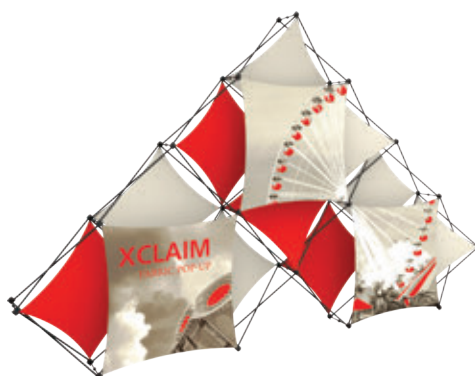

14' full height display  
footprint dimensions:  
164.99" w x 103.88" h x 12.8" d  
**XCLM-10QP-K2**

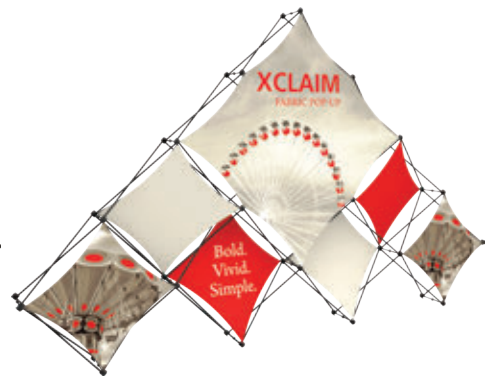

14' full height display  
footprint dimensions:  
164.99" w x 103.88" h x 12.8" d  
**XCLM-10QP-K3**



All Xclaim popups are eco-friendly and have a limited lifetime warranty.

# POPOP DISPLAY SYSTEMS



## RELIABLE. PORTABLE. ESSENTIAL.

The Coyote™ popup display system combines reliability, portability and style • State-of-the-art rare earth neo magnets on individual channel bars make Coyotes fast and easy to popup and breakdown, especially when compared to complicated “snap in” channel bars and fragile locking style systems • All Coyote displays are offered in curved or straight systems, single or double sided • Option of combining either captivating graphic mural panels or versatile Velcro-friendly fabric panels





# COYOTE™ POPUP DISPLAY SYSTEMS

This fully magnetic popup display system provides a graphic or Velcro receptive fabric backwall. Coyote™ popup displays require no tools for assembly, are portable, versatile, durable and easy to use. The Coyote line features a plethora of accessory options to add such as shelves, monitor mounts and case-to-counter conversion kits and graphics.



## FABRIC CHOICES

All Coyote popup display systems are available with printed graphic murals or "Velcro-friendly" fabric panels of your choice. Actual fabric color may vary slightly.

regal - smooth exhibit & display fabric



R01 carbon R02 chrome R03 storm R04 sapphire R28 azure blue

premier - ribbed exhibit & display fabric



R12 nebula R04 monarch R28 persian blue R29 beach D70 eggshell

R30 maroon R02 steel R03 charcoal R15 cinder R01 lava



4' tabletop  
footprint dimensions:  
45.5" w x 30.63" h x 12.5" d  
**COY-KKG-1X1-C**



6' tabletop  
footprint dimensions:  
73" w x 30.63" h x 19.25" d  
**COY-KKG-2X1-C**



6' tabletop  
footprint dimensions:  
73" w x 59.38" h x 19.25" d  
**COY-KKG-2X2-C**



8' tabletop  
footprint dimensions:  
97.25" w x 59.38" h x 25" d  
**COY-KKG-3X2-C**



6' full height  
slim-line display system  
footprint dimensions:  
73" w x 87.56" h x 19.25" d  
**COY-KKG-2X3-C**



8' full height  
standard display system  
footprint dimensions:  
97.25" w x 87.56" h x 25" d  
**COY-KKG-3X3-C**



10' full height  
standard display system  
footprint dimensions:  
118" w x 87.56" h x 36.5" d  
**COY-KKG-4X3-C**



8' serpentine  
full height display system  
footprint dimensions:  
102" w x 87.56" h x 20.25" d  
**COY-KKG-ST-8**



11' serpentine  
full height display system  
footprint dimensions:  
129" w x 87.56" h x 22" d  
**COY-KKG-ST-10**



11' standard horseshoe  
full height exhibit system  
footprint dimensions:  
113" w x 87.56" h x 54" d  
**COY-KKG-HS**



17' deluxe horseshoe  
full height exhibit system  
footprint dimensions:  
193.5" w x 87.56" h x 59.5" d  
**COY-KKG-DHS**



20' gullwing  
full height exhibit system  
footprint dimensions:  
231" w x 87.56" h x 41" d  
**COY-KKG-GW**



20' serpentine  
full height exhibit system  
footprint dimensions:  
217.75" w x 87.56" h x 60.5" d  
**COY-KKG-SPNT**



## COYOTE™ MINI

- approx. 20% smaller than standard Coyote™ tabletops
- entire display rolls up into special storage sleeve which slides into a padded carry case
- kit includes frame, channel bars, front curved graphic panels, carry case & 2 lights
- add an optional OCS hard case for shipping or extra secure storage



approx. 5' mini tabletop kit  
footprint dimensions:  
57.25" w x 48.25" h x 11.75" d  
**COY-M-KKG-2X2-C**



6.5' mini tabletop kit  
footprint dimensions:  
77.5" w x 48.25" h x 16.25" d  
**COY-M-KKG-3X2-C**



easy rollup carry bag holds Coyote™ Mini hardware and graphics

## BUBBLE PANEL

**COY-K-GBBP-O**

- forward facing, convex panel
- panel can be fabric, opaque graphic or rear illuminated graphic (light kit sold separately)
- hardware can be stored with display in case



## MONITOR MOUNT

**COY-MM**

- fully integrates with straight or curved Coyote™ systems
- one panel cut to fit the monitor\*
- VESA bolt compatible
- max weight = 50 lbs
- LCD max size = 23"

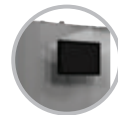

not recommended for plasma or CRT units



## INTERNAL SHELF KIT

**COY-IS-CK**

- presents products or literature
- comes with 2 clear acrylic shelves to be used horizontally or at 45° angles
- max capacity per shelf = 15 lbs, max per quadrant = 45 lbs
- for use with curved frame only
- lighting package available (not to be stored with display)



## COYOTE TOWER

**COY-3-G-TOW**

- an unexpected addition to any display; large or small, exhibit or P.O.P.
- back-lit panels illuminate your graphics (optional upgrade)
- coordinates with the look and style of your Coyote popup display



\*Monitors not included.  
All Coyotes come with a limited lifetime hardware warranty.

## OCX CASE TO COUNTER CONVERSION



### OCX

- premium latches for maximum strength
- blow molded transit case
- built in wheels, handle
- light storage in the lid
- UPS approved

### ROLL WRAP: OCX-C2C-G

- available in carpet or graphic
- converts OCX to a counter
- polymer counter surface exposed
- optional wood counter top can be added in your choice of silver, black, mahogany or natural

### STRETCH WRAP: OCX-SW-G

- stretch fabric pullover
- converts OCX to a counter
- polymer counter surface covered by fabric

## OCP-2 CASE TO COUNTER CONVERSION



### OCP-2

- new premium latches for maximum strength
- hinged lid with internal light storage
- robust, roto-molded plastic

### ROLL WRAP: OCP2-C2C-G

- available in carpet or graphic
- converts OCP-2 to a counter
- polymer counter surface exposed

### STRETCH WRAP: OCP2-SW-G

- stretch fabric pullover
- converts OCP-2 to a counter
- counter surface covered by fabric

## OCP ELITE CASE TO COUNTER CONVERSION



### OCP-ELITE

- heavy-duty shipping and storage case
- lid can be used as a step stool
- access door provides storage when unit is used as a counter
- UPS approved

### ROLL WRAP: ELITE-C2C-G

- available in carpet or graphic
- converts OCP Elite to a counter
- counter surface exposed

### STRETCH WRAP: ELITE-SW-G

- stretch fabric pullover
- converts OCP Elite to a counter
- counter surface covered by fabric



# FIND THE PERFECT FABRIC OR MODULAR DISPLAY IN THE **MODULAR CATALOG**



**FABRIC DISPLAYS**  
OFF-THE-SHELF  
TO CUSTOM



**MODULAR SYSTEMS**  
LIGHT BOXES, EXHIBITS,  
ACCESSORIES



**WIDEST RANGE OF OPTIONS**

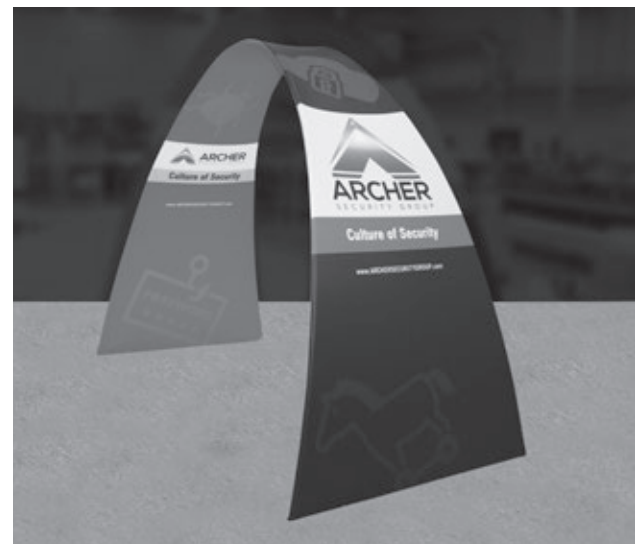

# FOLDING DISPLAY PANELS



## ADAPTABLE. FUNCTIONAL. PERFORMANCE.

Premium portable provide a professional appearance without the fuss • Our variety of portable folding panels are superbly crafted with seamless panels made of ultra-light core material • Covered on both sides with polyester fabric, which come in a plethora of color choices and options • Use the Velcro-friendly panels as a way to feature your message or add optional detachable graphics



# HERO™ DISPLAY PANELS

Hero™ panel displays are durable premium exhibit panel kits that feature the convenience of folding panels with elegant, seamless panel construction. Hero kits are available in a variety of fabric colors and feature concealed hinges with unique 2" radius curved ends to lend a polished appearance.



fits in an OCH case (case not included, see p. 84)

shown with optional graphics H16

—3'11" HIGH—  
—7'10" HIGH—

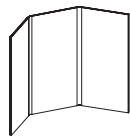

HERO H02-1  
tabletop display



HERO H03  
tabletop display with  
backlit header

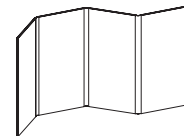

HERO H05  
tabletop display

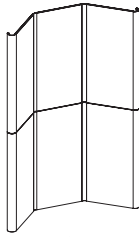

HERO H09  
full height exhibit with  
curved end caps

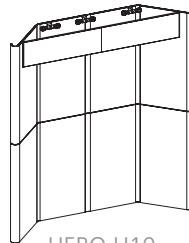

HERO H10  
full height exhibit with curved  
end caps and backlit header

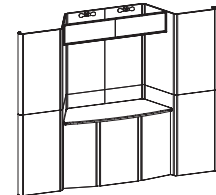

HERO H17  
10' full height exhibit kit with  
curved end caps & backlit header

## FABRIC CHOICES

All folding panel display systems are available with printed graphic murals or "Velcro-friendly" fabric panels of your choice. Actual fabric color may vary slightly.

regal - smooth exhibit & display fabric



R01 carbon R02 chrome R03 storm R04 sapphire R28 azure blue

premier - ribbed exhibit & display fabric



R12 nebula R04 monarch R28 persian blue R29 beach D70 eggshell  
R30 maroon R02 steel R03 charcoal R15 cinder R01 lava

# HORIZON™ DISPLAY PANELS



- main panel sizes approximately = 24" w x 36" h
- custom sized panel displays are available
- shown with optional detachable graphics
- available in a variety of fabric color options shown below



**WEIGHS** Horizon 3  
12 LBS HZ-TT-S

shown with premium printed table throw (p. 35)



**WEIGHS** Horizon 5  
13.5 LBS HZ-TT-M



**WEIGHS** Horizon 6  
22 LBS HZ-6



**WEIGHS** Horizon 8  
31 LBS HZ-8

## FABRIC CHOICES

All folding panel display systems are available with printed graphic murals or "Velcro-friendly" fabric panels of your choice. Actual fabric color may vary slightly.

regal - smooth exhibit & display fabric



premier - ribbed exhibit & display fabric







# VOYAGER™ FOLDING PANELS

The Voyager™ has been specially developed as a briefcase style tabletop display and is a great choice for promotions on the go. It has a rigid, thermo formed ABS exterior and a black, Velcro friendly fabric interior. Detachable graphics allow for easy message changes! Headers shown are an additional option. Extra graphics can be stored in the display case and packed away for easy storage.



WEIGHS 5 LBS **VY-1**

Voyager Mini kit (small)  
open dimensions: 48" w x 18" h  
closed dimensions: 24" w x 18" h



WEIGHS 6.5 LBS **VY-2**

Voyager Maxi kit (medium)  
open dimensions: 48" w x 24" h  
closed dimensions: 24" w x 24" h



WEIGHS 8.25 LBS **VY-3**

Voyager Mega kit (large)  
open dimensions: 48" w x 32" h  
closed dimensions: 24" w x 32" h



WEIGHS 8.25 LBS **VY-4**

Voyager Supreme kit (x-large)  
open dimensions: 64" w x 24" h  
closed dimensions: 32" w x 24" h



WEIGHS 10 LBS **VY-5**

Voyager Monster kit (xx-large)  
open dimensions: 64" w x 32" h  
closed dimensions: 32" w x 32" h



## VOYAGER CARRY BAG

- Voyager Mini bag: VY-1-BG
- Voyager Maxi bag: VY-2-BG
- Voyager Mega bag: VY-3-BG
- Voyager Supreme bag: VY-4-BG
- Voyager Monster bag: VY-5-BG



# ACCENTS & ACCESSORIES



## FINAL. FUNDAMENTAL. FINESSE.

Portable counters and kiosks provide ample storage and style to complement our vast array of 8', 10' and 20' exhibit kits and displays • Accent lighting kits and solutions help stage a powerful, impactful presence that you desire • Portable transit and shipping cases are designed to protect your exhibit investment • From sign stands and literature racks to poster frames and bag dispensers, a variety of display additions and accessories are at your fingertips



## FREESTANDING TABLET STANDS

The freestanding iPad and Tablet Stands are smart, lightweight and portable and make it easy to incorporate media into any environment.



Landscape view



Back



### IPAD STAND PAD12-02A-BLACK PAD12-02A-SILVER PAD12-02A-WHITE

- displays iPad 2<sup>nd</sup>, 3<sup>rd</sup>, 4<sup>th</sup> gen and Air models\*
- portrait or landscape
- security screws, allen key and bolts make the unit both durable and theft resistant
- base can be bolted to the floor for extra security
- offered in white, black and silver
- carry bag available as an upgrade



### UNIVERSAL TABLET STAND PAD21-04

- displays multiple tablet styles or iPad\*
- portrait or landscape
- security screws, allen key and bolts make the unit both durable and theft resistant
- base can be bolted to the floor for extra security
- features a telescopic, adjustable-height pole, height minimum 28.88" - maximum 49.81" h



## TENSION FABRIC IPAD STANDS

Are you looking to incorporate iPads into your display or environment? Sleekly designed free-standing iPad stands and kiosks make it easy to encourage interactivity, present information and engage your customers in any space. Stands feature stretch fabric graphics.



### IPAD STAND 01 TABLET-STD-01



- 30" w x 84" h x 23" d
- small monitor mount\*, holds 32" TV/32 lbs max
- iPad holder (2<sup>nd</sup>, 3<sup>rd</sup>, 4<sup>th</sup> gen and Air models)\*
- pillowcase fabric graphic



### IPAD STAND 02 TABLET-STD-02



- 20.25" w x 85.11" h x 23.8" d
- iPad holder (2<sup>nd</sup>, 3<sup>rd</sup>, 4<sup>th</sup> gen and Air models)\*
- pillowcase fabric graphic



### IPAD STAND 03 TABLET-STD-03



- 19.98" w x 64.34" h x 15.2" d
- iPad holder (2<sup>nd</sup>, 3<sup>rd</sup>, 4<sup>th</sup> gen and Air models)\*
- pillowcase fabric graphic



### IPAD STAND 04 TABLET-STD-04

- 26.26" w x 46.26" h x 22.64" d
- iPad holder (2<sup>nd</sup>, 3<sup>rd</sup>, 4<sup>th</sup> gen and Air models)\*
- pillowcase fabric graphic

\*Monitors and tablet devices not included.

# LINEAR™ KIOSKS

Linear™ Monitor Kiosks add function and flare to any space. Extrusion based construction coupled with your choice of rigid graphic infill panels or frosted plex panels make these kiosks sturdy and versatile.



## LINEAR KIOSK 01 LN-K-01

- 54.4" w x 99" h x 23.25" d
- monitor mount\*
- fabric canopy
- approximate weight = 125 lbs



## LINEAR KIOSK 05 LN-K-05

- 25.38" w x 72.25" h x 18.5" d
- monitor mount\*
- approximate weight = 30 lbs



# CHARGING STATIONS

Formulate® Charging Stations add technology and great value for visitors in need of a quick charge. Excellent for retail applications, trade shows and events.



## CHARGING TOWER FMLT-CHRG-01

- 33.56" w x 86.81" h x 33.46" d
- features 16 high-speed charging tips: (8) Micro USB for Android devices and (8) Apple 8-pin for Apple iPhone/iPad/ Lightning devices
- features a circular fabric header for branding and an illuminated fabric center structure
- base and tabletop color offered in choice of four thermoform color options

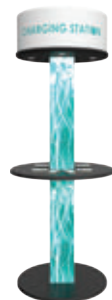

charging stations are available in your choice of finishes

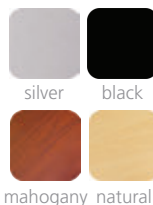

## CHARGING COUNTER FMLT-CHRG-COUNTER-01

- 23.72" w x 41.54" h x 23.62" d
- features 8 high-speed charging tips: (4) Micro USB for Android devices and (4) Apple 8-pin for Apple iPhone/iPad/ Lightning devices
- features stretch fabric graphic
- tabletop offered in choice of four thermoform color options

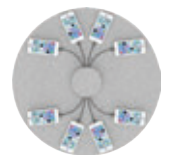

top view

\*Monitors and devices not included. See more kiosks on p. 22. (Vector Frame)



## TENSION FABRIC COUNTERS

Add modern flare to your trade show exhibit, event or POP display with Formulate® and Symphony™ fabric counters. With a variety of options to choose from, mix and match to create the ideal display or reception set up.



**PILLAR**  
W-01-C



**HALF MOON**  
W-02-C



**ELLIPSE**   
W-03-C



**BULLET**  
W-04-C



**OVAL**   
W-05-C



**BAR**  
W-06-C-04

## SYMPHONY™ COUNTERS

Symphony™ counters provide a unique, sleek design that lends an attractive element to any trade show or POP display. Symphony counters combine extrusion-based hardware with state-of-the-art PRINTED or SOLID COLOR stretch fabric silicone edge fabric graphics (SEG).



**OVAL**  
SYM-OV



**RECTANGLE**  
SYM-RCT



**BULLET**  
SYM-BLLT



**OVAL DOUBLE GRAND**  
SYM-OV-DBL-GRND



**3 QUAD KIT**  
SYM-QD-3

tension fabric counter tops are available in your choice of finishes



silver black mahogany natural

counter stretch skirts are available in custom printed options as well as the following colors:



amethyst ruby sapphire emerald silver jet

## COUNTERS & KIOSKS

Counters and kiosks can be used to accessorize any trade show, event or permanent space. With a variety of different counters and kiosks to choose from, mix and match to create the best-suited display.



### HOPUP™ COUNTER HOP-CT-2

- 41.75" w x 39.69" h x 14.25" d
- collapsible display counter
- Velcro applied fabric graphics
- includes clear internal shelf
- top available in four laminate finish options



### EMBRACE™ COUNTER EMB-CT

- 40.95" w x 40.23" h x 14.95" d
- collapsible display counter
- includes clear internal shelf
- push-fit fabric graphics
- top available in four laminate finish options



Counter tops are available in your choice of four thermoform finishes



silver black mahogany natural

**OCH2**  
wheeled  
molded case  
included  
(p. 84)



### MONITOR KIOSK VB-MK-01



- medium monitor mount\*
- max weight = 50 lbs
- comes with 1 OCH2 case
- \*monitor not included

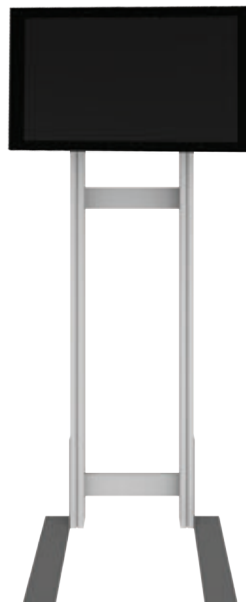

### MONITOR KIOSK PM4S3-MK-M PM4S3-MK-L



- medium or large monitor mount\*
- medium holds 32-55"
- large holds 40-65"
- max weight = 40 lbs
- OCFM case optional; ships freight
- \*monitor not included



### CAMPAIGN CP-B2

- counter dimensions not including canopy 32" w x 34.5" h x 18.5" d
- Velcro fabric graphic
- quick assembly
- strong & easy to clean plastic parts



## SIGN STANDS

Easily display a graphic or message with a versatile and easy-to-assemble sign stand. We offer stands that feature adjustable posts, portrait and landscape sign configurations and more.



### SPARTAN

- 52.75" h
- sleek, sign holder features acrylic pocket to hold 8.5" w x 11" h literature
- silver aluminum alloy post and circular black base
- add second post to hold a larger rigid graphic



### ADVOCATE ADVOCATE

- telescopic post offers variable height from 30.5" - 48"
- aluminum sign holder holds 8.5" w x 11" h paper
- frame can be rotated 360 degrees or any desired angle
- chrome finish



### SNAPPER STAND SNP-STAND

- 40" h
- stylish, easy snap-open 11" w x 17" h frame
- frame can be used in portrait and landscape configurations
- silver aluminum sign holder, post and base

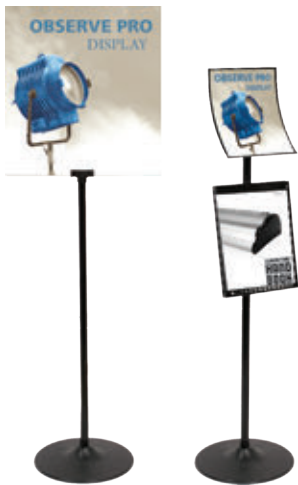

### OBSERVE PRO OBS-LP-SYS

- 48" h
- lightweight, snap-together info center with 12" dia. base
- stylish curved header & adjustable brochure holder
- accepts 8.5" w x 11" h literature & graphic



### OBSERVE DELUXE OBS-DLX

- 74.5" h
- stylish double sided curved design
- holds two 24" w x 36" h bubble graphics
- recommended printing material: .040"-.125"
- elegant brushed silver
- sturdy steel base with removable and adjustable brochure pockets



### OBSERVE GRAND OBS-G

- 68" h
- sleek info center includes sturdy base & adjustable shelf
- accepts 22.88" w x 27.5" h graphic size
- single or double sided
- holds a 3/16" thick mounted graphic

## SIGN STANDS

Easily display a graphic or message with a versatile and easy-to-assemble sign stand. We offer stands that feature adjustable posts, portrait and landscape sign configurations and more.



### TRAPPA POST

- versatile Trappa Posts feature snap sign frames & come in a variety of configurations and sizes
- sturdy aluminum posts and heavy domed steel plate ensure stability
- choice of silver or black snap frames, large or small, landscape, portrait or diagonal
- front loading graphic mechanism makes graphic changes easy
- includes clear protective lenses

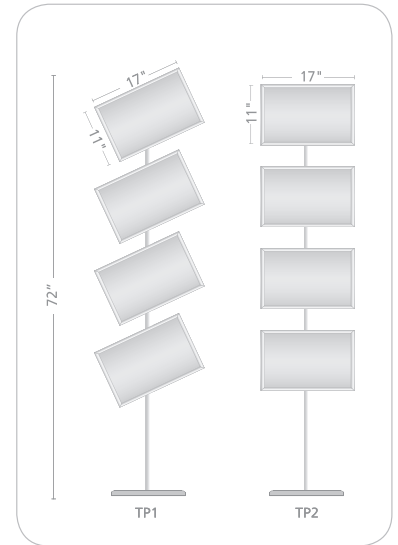

## TOWERS

Maximize your messaging in any lobby, entryway, at any event or tradeshow with a versatile display tower. From configurable to illuminated features, you are sure to find a tower that suits your messaging needs.



### TRI-TOWER DELUXE TRI-TOWER-DLX

- 26.75" w x 72" h free-standing modern-looking triangular display
- durable aluminum extrusion construction coupled with rigid graphic infill panels
- convenient sliding cam locks make graphic changes quick and easy
- heavy-duty laminated foot plate
- simple assembly
- optional lighting kit available



### TOWER

- collapsible double sided free-standing tower
- just add the optional lighting kit and turn your tower into a free-standing lightbox!
- 24" or 33" w x 72" h "bubble" panels for maximum visibility
- recommended printing material: .040"-.125"
- your choice of silver or black aluminum edge extrusions
- black laminate top & bottom plates



### CUBE TOWER PRISM TOWER

- easy-to-use snap frames featured on all sides
- variety of configurations and sizes available
- choice of silver or black snap frames
- seamlessly display multiple graphics and messages
- front loading graphic mechanism makes graphic changes easy
- frames come with clear protective lenses
- options include wheels or feet
- custom sizes also available



# LITERATURE RACKS

Literature racks are used to simply display brochures and can be used in countless applications, from trade shows, conference rooms and events to lobbies and more.



**ZEDUP 1**  
black: ZD-1-B  
silver: ZD-1-S

- 6 pocket rack
- can be stored or shipped loaded with literature



**ZEDUP LITE**  
silver: ZD-LITE

- 6 pocket rack
- collapsible
- lightweight version of the ZedUp
- constructed from aluminum & plastic for reduced weight

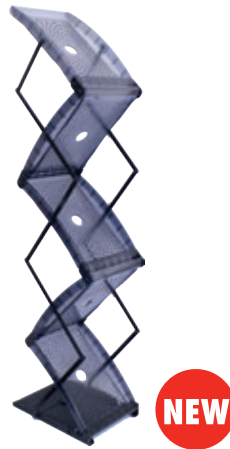

**QUANTUM DOUBLE SIDED**  
black: QNTM-DS

- 5 pocket rack
- collapsible
- constructed from plastic/lightweight



**QUANTUM SINGLE SIDED**  
black: QNTM-SS

- 4 pocket rack
- collapsible
- constructed from plastic/lightweight



**INNOVATE**  
black: INN-B  
silver: INN-S

- modular design
- 10 pockets
- packs in 3 separate parts for reduced shipping size



**ILLUSION**  
black: IL-1-B  
silver: IL-1-S

- fast-folding cantilever rack
- 4 front facing pockets



**10 UP**  
black: 10UP-B

- strong & stable
- 10 pockets
- packs flat



All literature racks come with a five year limited warranty, a carry bag, and are an eco-friendly choice.

## TRAPPA SNAP FRAMES

Trappa Snap frames snap open from the front to allow quick and easy graphic changes. No tools are required. Comes standard with clear protective lenses, fully assembled and ready to hang.



### TRAPPA POSTER FRAME



- black or silver anodized finish with precision mitered corners
- spring loaded aluminum extrusions mounted to a high-impact polystyrene backer
- trappa frame edges snap open from the front to allow quick and easy graphic changes with no tools required
- available in a wide range of standard sizes & includes a clear anti-glare lens



### POSTER SNAPPER



- adjustable hanging clips slide along the top rail to match desired spacing
- hanging clips feature both top opening for clear nylon line mount, and recessed pocket for S-hook suspension
- rails snap open and shut for quick graphic changes
- clean, simple, elegant look
- comes in 4 different standard widths: 24", 30", 36", 48"
- custom cut width available up to 60"



### TRAPPA LIGHTBOX



- only 1" thick (single sided only)
- 50,000 hr bulb life
- evenly distributed light via LED diffuser panel
- snap frames allow easy graphic changes
- wall mounting hardware
- power supply with 78" cord

#### AVAILABLE SIZES:

- LED-SNAP-01: 16" w x 20" h
- LED-SNAP-02: 22" w x 28" h
- LED-SNAP-03: 24" w x 36" h
- LED-SNAP-04: 30" w x 40" h
- LED-SNAP-05: 36" w x 48" h

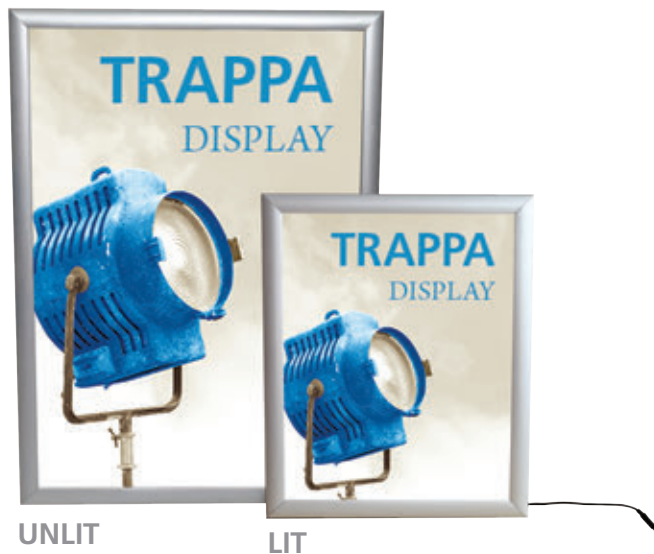



## DISPLAY ADDITIONS

From sign stands to poster frames, towers, bag dispensers and more, display accessories and accents are designed to help add the final touches, function and flare to any display or space.

### APEX APEX



- double sided plastic a-frame
- can be printed directly on the plastic for a smooth look
- for indoor or outdoor use



### WEDGE WED-1-B



- combine multiple units for longer and taller displays
- graphic size is variable
- black only
- graphics not included

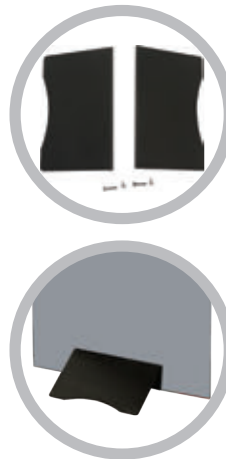

### AMBASSADOR AMBASSADOR



- magnetic name badge
- 2.94" w x 1.25" h
- silver finish



### OASIS OASIS



- highly portable
- three arm collapsible bag dispenser
- shiny silver finish



### STEP STOOL STEP STOOL-BLUE



- sturdy EZ FOLDZ step stool
- 300 lb capacity
- folds flat for storage & transport
- blue only



## SLIMLINE LED LIGHTING

Incorporate modern, bright LED lights into your display and draw attention to your brand and message with elegance. With bright, cool lights and contemporary slim profiles, you can modernize your display, set the stage and better communicating a clear message. Choose from several LED lighting solutions that will make your message and products shine.



### LED FLOOD LUM-LED4-ORL-B

- low voltage 12 watt spotlight
- 17.16" long from end to end
- mounts to dovetails and extrusion channel
- available in black only

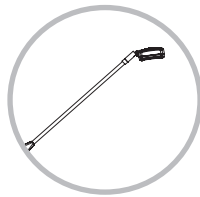

### LED SPOT LUM-LED3-ORL-B

- low voltage 5 watt slender spotlight
- 17.18" long from end to end
- mounts to banner stands
- available in black only

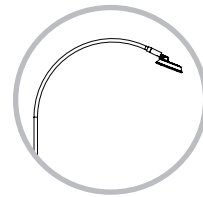

### LED STRIP LUM-LED5-ORL-B

- low voltage 12 watt
- 16.1" long from end to end
- mounts to dovetails and extrusion channel
- available in black only

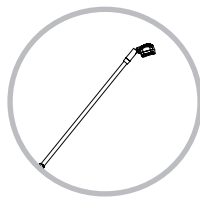

### LED EXHIBITION LUM-LED6-ORL-B

- low voltage 12 watt spotlight
- 17.13" long from end to end
- mounts to extrusion channels
- available in black only

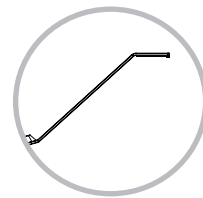

### LUMINA 200 LED black: LUM-LED2-ORL-B silver: LUM-LED2-ORL-S

- LED Lumina 200 floodlight
- Uses multi cups chip on board (MCOB) light technology and features a slim profile
- LED rated for 20,000 continuous hours
- 19" long from end to end

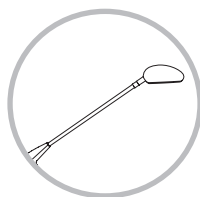

LIGHTING IS AN **IMPORTANT** ELEMENT TO ANY DISPLAY



LIGHTING DRAWS ATTENTION TO YOUR BRAND AND MESSAGE WITH ELEGANCE



# LUMINOSITY™ DISPLAY LIGHTING

Lighting can create a powerful, impactful presence or display. Illumination is an important piece of the puzzle to achieve the mood, style and staging that you desire. A variety of Luminosity™ display lights, lighting kits and solutions are available to help your clients make their projects shine!



## LUMINA 1 black: LUM-1-B chrome: LUM-1-C

- low voltage 50 watt spotlight & universal fittings kit
- "goose neck" arm
- mounts horizontally
- LED option available

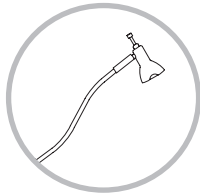

## LUMINA 2 LUM-2-1

- low voltage 50 watt slender banner stand spotlight
- mounts to a vertical pole
- brushed stainless steel finish
- LED option available

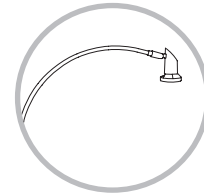

## LUMINA 5 LUM-5

- low voltage 50 watt spotlight & universal fittings kit
- deluxe chrome head
- telescopic arm
- extends from 7" - 22" long
- LED option available

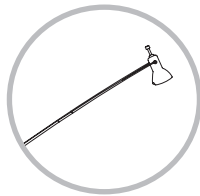

## LUMINA 6 LUM-6

- low voltage, 50 watt spotlight & universal fittings kit
- stylish curved twin arms
- silk black only
- LED option available

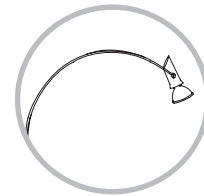

## LUMINA 8 black: LUM-8-B silver: LUM-8-C

- 12 volt spotlight with straight arm & adjustable head
- includes 110 volt UL approved transformer, 50 watt bulb & universal fittings kit
- 17" long from end to end
- LED option available

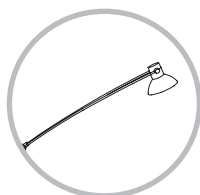

## LUMINA 200 FLOODLIGHT LUM-200-ORL

- 110 volt ETL approved wall washer floodlight with a straight arm & adjustable head
- light includes 120 watt halogen bulb
- 19.5" long from end to end
- silk black finish

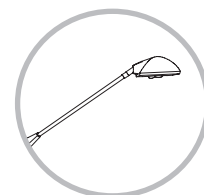

## UNIVERSAL LIGHT CLAMP KIT

UNI-LT-CLP30  
UNI-LT-CLP50

- comes standard with the Lumina 1, 3, 4, 5, 6, 8 and allows our lights to fit a majority of banners, truss & panel kits



## SPT CASE

SPT-CASE

- EVA semi-rigid lighting case
- foam-lined padded compartments
- holds two Lumina 200 lights & power supply
- fits Lumina 1, 2, 5, 6, 8 and power supply



## LED BULB OPTION

LUM-LV-LED-BLB16

- a green solution for Lumina 1, 2, 5, 6, 8
- 50 watt equivalent LED bulb



## LUMINA SPARE BULB KIT

LUM-BULB

- (2) 50 watt low voltage spare bulbs in a padded, protective EVA formed case



## FLOODLIGHTS & WALL WASHERS

### LED FLOOD LIGHT

LED-FLOOD

- 85-265 voltage, 42 watt LED Flood light (equivalent to 400 watt halogen)
- projects cool WHITE light
- 7.4" w x 9.44" l x 5.11" d
- angles to 120°
- UL approved



### MINI LED FLOOD LIGHT

LED-10W-FLOOD-RGB

LED-10W-FLOOD-W

- 10 watt LED Flood light
- projects cool WHITE or RGB spectrum light
- remote control provided with RGB version
- each light measures 4.49" w x 3.39" h x 3.98" d
- angles to 120°
- UL approved



### COLOR BLAST ACCENT LIGHTS

- 85-265 voltage, 13 watt LED blast light
- projects your choice of warm or cool WHITE, and a RGB spectrum flashing pattern
- 7" round x 7" h (when faceplate is flush with base and not angled)
- angles to 60°
- UL approved



**LED-WRM-WHT-BLAST**

Features a warm white LED light output; good for light-colored and neutral graphic prints. 3,000K



**LED-COOL-WHT-BLAST**

Features a cool LED light output; good for darker graphic prints. 6,000K



**LED-RGB-BLAST**

Features multi-pattern flashing RGB LED light output; RGB spectrum cannot be controlled.

It's critical to protect your tradeshow exhibit investment with a quality-constructed transit and shipping case. An extensive selection of exhibit and display cases and crates to choose from that are all made in North America and are designed to house specific lines of exhibits and displays for maximum portability and protection during shipping.

## LIGHTING & ACCESSORY CASE OCA-2

- ideal for lights and accessories
- secure straps help to ensure case will remain closed during transport
- interior size:  
32.81" w x 4.13" h x 13.75" d
- exterior size:  
34" w x 7" h x 15" d
- weight when empty: 8 lbs



## SMALL & LARGE GRAPHIC CASES

### SMALL: OCS

### LARGE: OCL

- premium latches for maximum strength
- built in wheels and easy-to-grip molded handle

### OCS

- interior size:  
14" w x 39.81" h x 13.25" d
- exterior size:  
18" w x 42.25" h x 16.5" d
- weight when empty: 18 lbs

### OCL

- interior size:  
14" w x 51.5" h x 13.25" d
- exterior size:  
18" w x 55.13" h x 16.5" d
- weight when empty: 20 lbs



## BANNER STAND CASE OCB

- this expandable shipping case fits up to three swivel-foot banner stands with bags or one premium stand with bag\*
- also used for Formulate® Lite displays
- interior size min/max:  
min - 12" w x 30.13" h x 3.75" d  
max - 12" w x 47.13" h x 3.75" d
- exterior size:  
min - 14.56" w x 30.38" h x 5.88" d  
max - 14.56" w x 47.38" h x 5.88" d
- weight when empty: 9 lbs
- \*case does not fit Uno, Spring 5, Contender 48 or banners over 39.37" wide



## EXPANDABLE CASE OCE

- the perfect protective shipping and/or storage case for all Formulate® exhibit kits, hanging structures and accessory products
- adjustable roto-molded expandable display case
- adjustable lid and easy pin latch
- interior size min/max:  
min - 13.75" w x 39.63" h x 11.75" d  
max - 13.75" w x 64" h x 11.75" d
- exterior size min/max:  
min - 16.75" w x 39.88" h x 16.88" d  
max - 16.75" w x 64.25" h x 16.88" d
- weight when empty: 27 lbs
- separate fabric graphic converts the case into a counter



All cases come with a one year limited warranty, are an economic & eco-friendly choice & made in North America. Shipping dimensions may vary.

## STANDARD WHEELED DISPLAY CASE

### OCX

- light storage in the lid
- premium latches for maximum strength
- interior size: 35.75" w x 23.5" h x 13" d
- exterior size: 39.5" w x 26.75" h x 17" d
- weight when empty: 32 lbs
- optional wood counter top can be added in your choice of silver, black, mahogany or natural



## PREMIUM WHEELED DISPLAY CASE

### OCP-2

- premium latches for maximum strength
- hinged lid with internal light storage
- robust, roto-molded plastic
- interior size: 22" w x 35.5" h x 14.14" d
- exterior size: 26" w x 39.56" h x 17.75" d
- approximate weight when empty: 32 lbs



## DELUXE WHEELED DISPLAY CASE

### OCP-ELITE

- lid can be used as a step stool while assembling displays
- access door provides storage when unit is used as a counter
- interior size: 14.14" w x 31.75" h x 19.75" d
- exterior size: 16.75" w x 38.25" h x 26.25" d
- weight when empty: 31 lbs



## HOPUP/MEDIUM WHEELED CASE

### OC-HOP

- ideal for Hopup backwall displays (fits up to 4x3 hopup)
- built-in handle and wheels for easy transport
- interior size: 13.5" w x 35.5" h x 13.5" d
- exterior size: 15.5" w x 35.69" h x 17" d
- weight when empty: 17 lbs



### OCH

- roto-molded case for exhibits, graphics & accessories
- secure reinforced straps help to ensure case will remain closed during transport
- strong yet lightweight
- interior size: 23.25" w x 7.63" h x 46.5" d
- exterior size: 26" w x 12" h x 50" d
- weight when empty: 22 lbs



## LARGE DISPLAY CASE

### OCH2

- heavy-duty shipping and storage case
- ideal for Linear hybrid displays
- secure reinforced straps help to ensure case will remain closed during transport
- interior size: 24.13" w x 12.25" h x 47.25" d
- exterior size: 29" w x 15" h x 52" d
- weight when empty: 30 lbs
- wheels and handles recessed



All cases come with a one year limited warranty, are an economic & eco-friendly choice & made in North America. Shipping dimensions may vary.



# MODULAR SYSTEMS

## MODULAR DISPLAYS & FABRIC STRUCTURES

Modular exhibits typically feature extrusion-based frames and fabric graphics, are sophisticated in design and are often customizable and reconfigurable. Modular display sizes span from tabletop to 10 feet and 20 feet inline to island sizes.

Fabric structures and displays combine zipper pillowcase fabric graphics with lightweight aluminum tube structures. From exhibit kits to hanging signs, arches and other architectural structures, these displays are ideal for use in tradeshow, as retail displays and in corporate spaces to add advertising with style.

# FABRIC DISPLAYS & STRUCTURES

88 | **MODULATE**

MIX & MATCH | 10', 20', 30' KITS



94 | **FORMULATE® ESSENTIAL**

BANNERS | TABLETOP DISPLAYS | 8' DISPLAYS | 10' DISPLAYS



98 | **FORMULATE MASTER**

TABLETOP DISPLAYS | 10' DISPLAYS | 20' DISPLAYS | ACCENTS



116 | **FORMULATE DESIGNER SERIES**

10' DISPLAYS | 20' DISPLAYS | 30' DISPLAYS



132 | **FORMULATE FUSION 20' X 20' ISLAND KITS**



140 | **FORMULATE HANGING & ARCHITECTURAL STRUCTURES**

HANGING SIGNS | TOWERS | ARCHES | CONFERENCE WALLS

## SYMBOLS USED:



product made in North America



economy product



standard product



premium product



product can be recycled (does not include graphic)



product comes with a carry bag or case



rental product



new product

# MODULAR EXHIBIT SYSTEMS

## HYBRID PRO™ MODULAR DISPLAYS | 160

10' DISPLAYS | 20' DISPLAYS | ISLANDS



## VECTOR FRAME™ MODULAR DISPLAYS | 170

BANNER DISPLAYS | 10' DISPLAYS | 20' DISPLAYS | ACCENTS



## LINEAR™ PRO MODULAR DISPLAYS | 184

10' DISPLAYS | 20' DISPLAYS | ACCENTS



## MERCHANDISE EXPRESS™ MODULAR DISPLAYS | 188

POINT OF PURCHASE DISPLAYS



## ORBITAL EXPRESS™ TRUSS MODULAR DISPLAYS | 192

10' DISPLAYS | 20' DISPLAYS | ISLANDS | ACCENTS

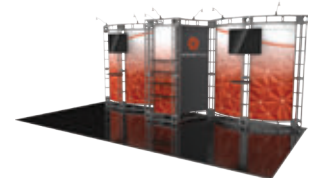

## ACCENTS & ACCESSORIES | 212

COUNTERS | LIGHTS | CASES



### WARRANTY KEY:



lifetime limited warranty (hardware)



5 year limited warranty (hardware)



1 year limited warranty (hardware)



90 day limited warranty (hardware)



graphics limited 1 year warranty (indoor products)



graphics limited 6 month warranty (outdoor & table throw products)

# FORMULATE **FABRIC** STRUCTURES

From straight and angular shapes to ergonomic, flowing forms, the Formulate® line of fabric exhibits and structures encompasses a full spectrum of beautiful fabric-based exhibits, environments and structures, off-the-shelf to custom. Formulate fabric structures and solutions combine shape, specialty fabrics, lightweight frames and lighting to create captivating and artistic presentations and spaces.

## Shapes to mix & match...

Formulate's off-the-shelf fabric structures couple lightweight aluminum tube frames with stretch, zipper pillowcase fabric graphics. Formulate fabric structures are formed with expert aluminum bending machinery and skilled welding and metal-working technicians. We offer a complete line of fabric backwalls, exhibit kits, hanging shapes and structures, towers, archways, walls, rooms and more.

## Off-the-shelf display systems and architectural structures include:

- Formulate inline tension fabric displays
- Formulate counters, kiosks, iPad stands & accessories
- Formulate hanging structures
- Formulate towers, funnels & arches
- Formulate Fusion island exhibits, conference rooms & more

With the endless off-the-shelf and customized options Formulate provides, you can mix and match to create the ideal display, booth or environment.

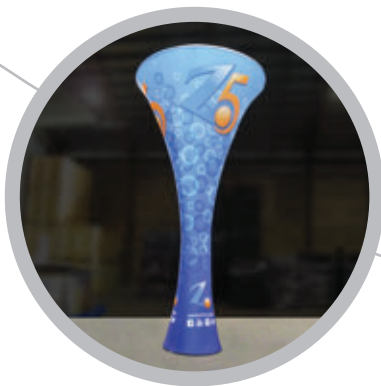

Formulate Funnel 02,  
p. 150



10' Formulate Master Vertical  
Curve Display, p. 101



Pinwheel Hanging  
Structure, p. 144

# MODULAR **EXHIBIT** SYSTEMS

Modular exhibit systems and displays provide exhibitors with sophisticated, custom-looking exhibits that stand the test of time and can adapt and evolve from show to show. Using standardized components as building blocks, modular displays can often be reconfigured to fit multiple size spaces and customized to fit unique needs.

**Modular exhibits are smart, versatile and often feature recyclable aluminum components that support longevity and reusability.**

Our modular exhibit systems are created by expert welding and metal-working technicians. With the latest state-of-the-art printing technology and large format printing capabilities, we ensure your desired message stands out from the competition; graphics are produced and finished by hand by highly-skilled sewers in North America.

**Off-the-shelf modular exhibit systems include:**

- Hybrid Pro™ Modular inline & island exhibit kits & counters
- Vector Frame™ banners, light boxes, exhibit kits, kiosks & counters
- Linear™ Pro modular inline exhibit kits, kiosks and counters
- Merchandise Express™ portable point-of-purchase displays
- Orbital Express™ Truss modular inline & island exhibit kits, counters, kiosks & accessories

With such an expansive range of off-the-shelf modular exhibit systems to choose from, you can easily create an impactful, versatile exhibit that will evolve with your exhibiting needs and demands over time.



Hybrid Pro Kit 01,  
p. 162



Hybrid Pro Kit 11,  
p. 164



Vector Frame Light  
Box, p. 172

MODULATE™  
MIX & MATCH



Modulate™ is a modular, fabric structure system that allows for hundreds of customized configurations of banners and backwalls that result in imaginative and original inline displays. Aluminum tube frames are coupled with zipper pillowcase fabric graphics to create versatile, eye-catching displays.

## DESIGN YOUR OWN COMBINATIONS

CHOOSE FROM 11 FRAME SHAPES & COMBINE TO CREATE A TAILORED INLINE DISPLAY



1

2

3

4

5



6

7

8

9

10

11

## MAKE UNIQUELY YOURS



DESIGN  
EXAMPLE

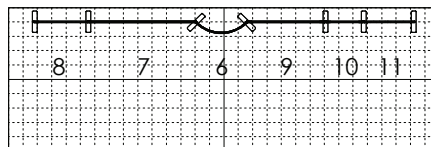

MODULATE | MIX & MATCH



Modulate displays come with a carry bag and a lifetime limited hardware warranty.

**NEW**

# MODULATE™ RECONFIGURABLE KITS

If you have a tradeshow schedule where you have multiple size spaces to plan for, Modulate™ is the perfect exhibit system. Modulate pre-defined 30' inline kits can reconfigure easily into smaller exhibit sizes with no extra parts or packaging!  
**Maximize your value in a versatile, reconfigurable system.**

## SNAP TOGETHER AND RECONFIGURE

### CONVERT A 30' INLINE



MOD-30-01

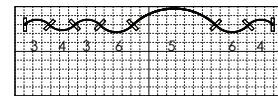

### INTO A 20' INLINE



MOD-20-01

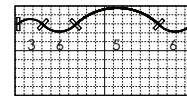

### OR TWO 10' INLINE DISPLAYS



MOD-10-01



MOD-10-02



MODULATE | RECONFIGURABLE KITS

**NEW**



**LIFE TIME**

Modulate displays come with a carry bag and a lifetime limited hardware warranty.



# PLAN FOR A VARIED TRADESHOW CIRCUIT

CONVERT A 30' INLINE



MOD-30-02

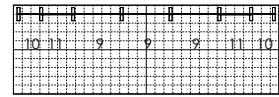

INTO A 20' INLINE



MOD-20-02

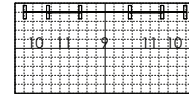

AND TWO 10' INLINE DISPLAYS



MOD-10-03



MOD-10-04



Modulate displays come with a carry bag and a lifetime limited hardware warranty.





# MAXIMIZE YOUR EXHIBIT VALUE

CONVERT A 30' INLINE



MOD-30-03



INTO A 20' INLINE



MOD-20-03

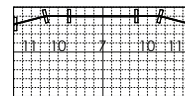

OR TWO 10' INLINE DISPLAYS



MOD-10-05



MOD-10-06



Modulate displays come with a carry bag and a lifetime limited hardware warranty.

# ENHANCE & MODERNIZE...

CONVERT A 30' INLINE

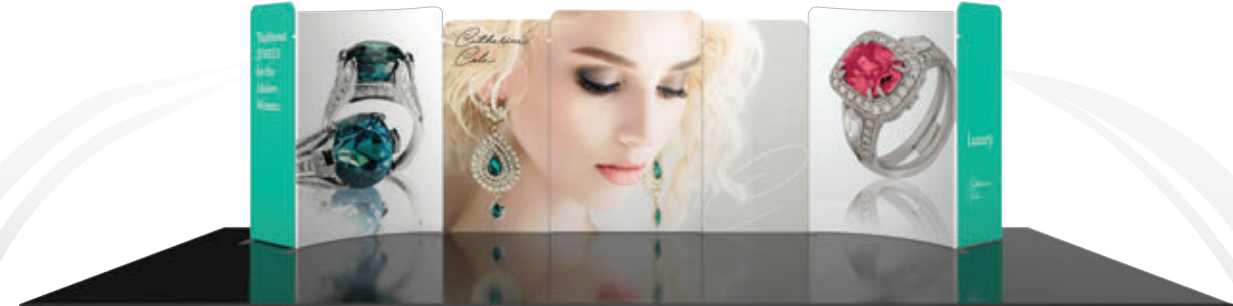

MOD-30-04

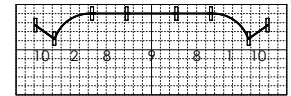

INTO A 20' INLINE

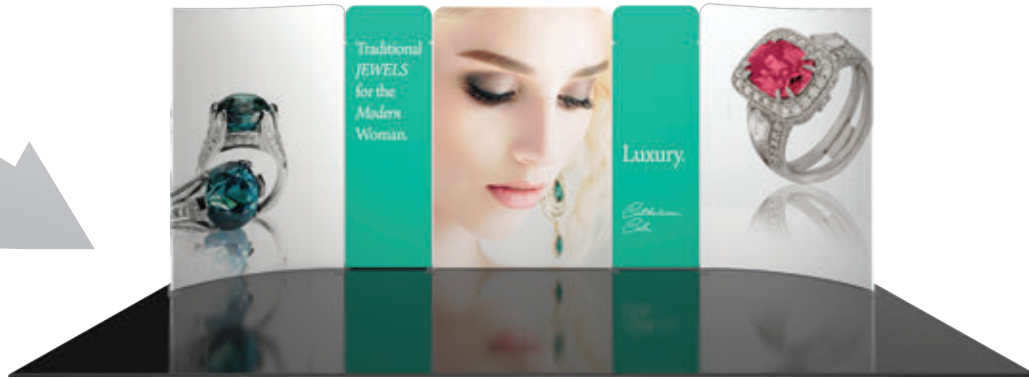

MOD-20-04



OR TWO 10' INLINE DISPLAYS



MOD-10-07



MOD-10-08



**NEW**

**MODULATE™**  
RECONFIGURABLE KITS

# TO WOW, ENGAGE & SELL

CONVERT A 30' INLINE



MOD-30-05

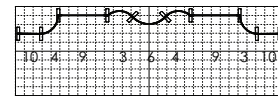

INTO A 20' INLINE



MOD-20-05

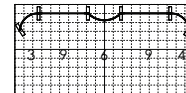

OR TWO 10' INLINE DISPLAYS



MOD-10-09



MOD-10-10



MODULATE | RECONFIGURABLE KITS

**NEW**



**LIFE TIME**

Modulate displays come with a carry bag and a lifetime limited hardware warranty.

# FORMULATE® ESSENTIAL | BANNER DISPLAYS

Formulate® Essential banner displays feature basic tubular frames coupled with pillowcase fabric graphics. The economy tube frames come with a one year limited warranty. Simply pull the graphic over the frame.

## FORMULATE ESSENTIAL BANNER – STRAIGHT

23.5" WIDE FMLT-ESS-S-600

36" WIDE FMLT-ESS-S-920

47.25" WIDE FMLT-ESS-S-1200

59" WIDE FMLT-ESS-S-1500

- standard height = 94.5"
- standard depth = 14.17"
- straight aluminum tube frame
- rounded corners
- bungee cords for easy assembly
- sturdy feet anchor the display
- pillowcase fabric graphic
- comes with carry bag



## FORMULATE ESSENTIAL BANNER – CURVED

23.5" WIDE FMLT-ESS-C-600

36" WIDE FMLT-ESS-C-920

47.25" WIDE FMLT-ESS-C-1200

59" WIDE FMLT-ESS-C-1500

- standard height = 94.5"
- standard depth = 15.75"
- curved aluminum tube frame
- rounded corners
- bungee cords for easy assembly
- sturdy feet anchor the display
- pillowcase fabric graphic
- comes with carry bag





**ENTICE**  
FMLT-ESS-ENTICE-01

31.5" w x 89.5" h x 17.88" d  
Entice is a double sided tension fabric display stand that features a small, clear acrylic shelf. Entice is offered with a curved or sloped top and allows you to dress up any space with your own graphic. Entice comes with a canvas over-the-shoulder carry bag. Shelf spans 34.5" w and is 6.25" deep, and can hold a maximum of 15 lbs.



**COBRA**  
FMLT-ESS-COBRA

36.25" w x 89.5" h x 34.5" d  
The Cobra is a single or double sided fabric banner stand. Simply connect the basic lightweight aluminum tube frame, slip the fabric graphic on and you have a sleek serpentine-curved banner stand in minutes. Includes a canvas carry bag.



*bungee corded poles allow for simple assembly\**



*easy to apply pillowcase fabric graphics*

\*select Formulate banners feature bungee cords

# FORMULATE® ESSENTIAL | TABLETOP & 8' DISPLAYS

## FORMULATE ESSENTIAL TABLETOP DISPLAYS

Formulate® Essential Tabletop displays have customary frame features, are portable and come in Straight, Vertical Curved and Horizontal Curved options. The economy aluminum tube frame features bungee cords, rounded corners and comes with a one year limited warranty. Simply pull the pillowcase fabric graphic over the frame and zip. All displays have an overall height of 5' and fit on an 8' wide table and come with a canvas carry bag.

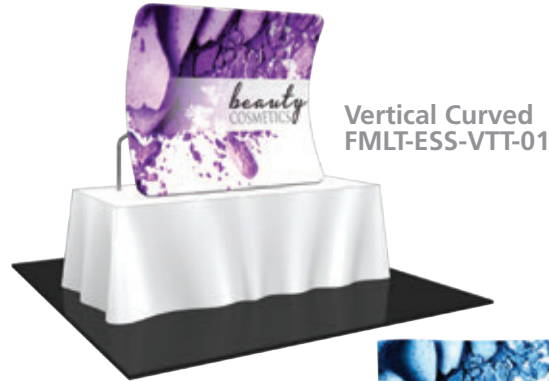

Vertical Curved  
FMLT-ESS-VTT-01



Straight  
FMLT-ESS-STT-01



Horizontal Curved  
FMLT-ESS-HTT-02

## FORMULATE ESSENTIALS 8' DISPLAYS

Formulate® Essential 8' displays have customary frame features, are portable and come in Straight, Vertical Curved and Horizontal Curved options. The economy aluminum tube frame features bungee cords, rounded corners and comes with a one year limited warranty. Simply pull the pillowcase fabric graphic over the frame and zip. All displays come with a canvas carry bag.



Straight  
FMLT-ESS-S08-01



Horizontal Curved  
FMLT-ESS-H08-02



Vertical Curved  
FMLT-ESS-V08-01

FORMULATE ESSENTIAL  
10' DISPLAYS

Formulate® Essential 10' displays have customary frame features, are portable and come in Straight, Vertical Curved, Horizontal Curved and Serpentine Curved options. The economy aluminum tube frame features bungee cords, rounded corners and comes with a one year limited warranty. Simply pull the pillowcase fabric graphic over the frame and zip. All displays come with a canvas carry bag.



Vertical Curved  
FMLT-ESS-V10-01



Straight  
FMLT-ESS-S10-01



Horizontal Curved  
FMLT-ESS-H10-02



Serpentine Curved  
FMLT-ESS-SC10-01



Formulate Essential displays come with a carry bag and a one year limited hardware warranty.

# FORMULATE® LITE | 8' & 10' DISPLAYS

## FORMULATE LITE 8'/10' DISPLAYS

Looking for a sharp, simple, portable fabric backwall that sets up in 5 minutes or less? Look no further. The Formulate® Lite 8' x 10' fabric backdrop is one of the fastest and easiest solutions you can find. In addition to the standard landscape/horizontal configuration, Formulate Lite can be turned on its side to create a portrait/vertical wall as well.

The sturdy, lightweight 30mm aluminum frame assembles with simple push-buttons. Simply stretch the graphic over the corners of the frame and you're done. You have an instant, impressive fabric backwall!

The Formulate Lite kit is supplied in a carry bag. Shown with an optional, upgraded OCB case.



Formulate Lite - portrait/vertical graphic  
FMLT-LT-01



Formulate Lite -  
landscape/horizontal graphic

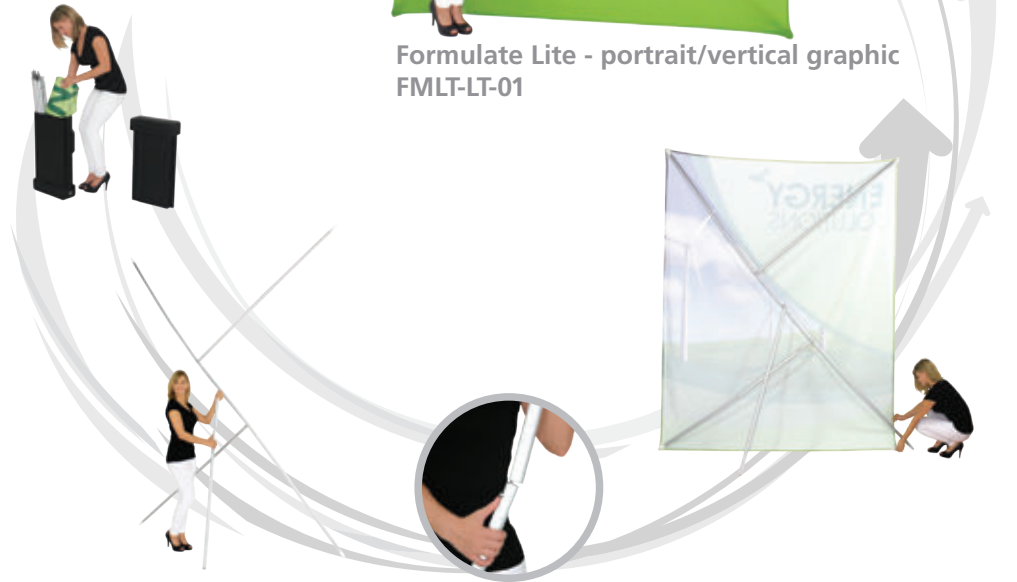

## FORMULATE MASTER 8' DISPLAYS

Simplicity and style make Formulate® Master 8' displays an ideal solution. Available in Straight, Vertical Curved and Horizontal Curved options, Formulate Master 8' displays are easy-to-assemble with snap-buttons and pull-over zipper pillowcase fabric graphics. All displays come in a portable, wheeled transit case.



Formulate 8S  
FMLT-WS8-01

Formulate 8H  
FMLT-WH8-01

Formulate 8V  
FMLT-WV8-01





**Formulate TT1**  
FMLT-WTT-V01

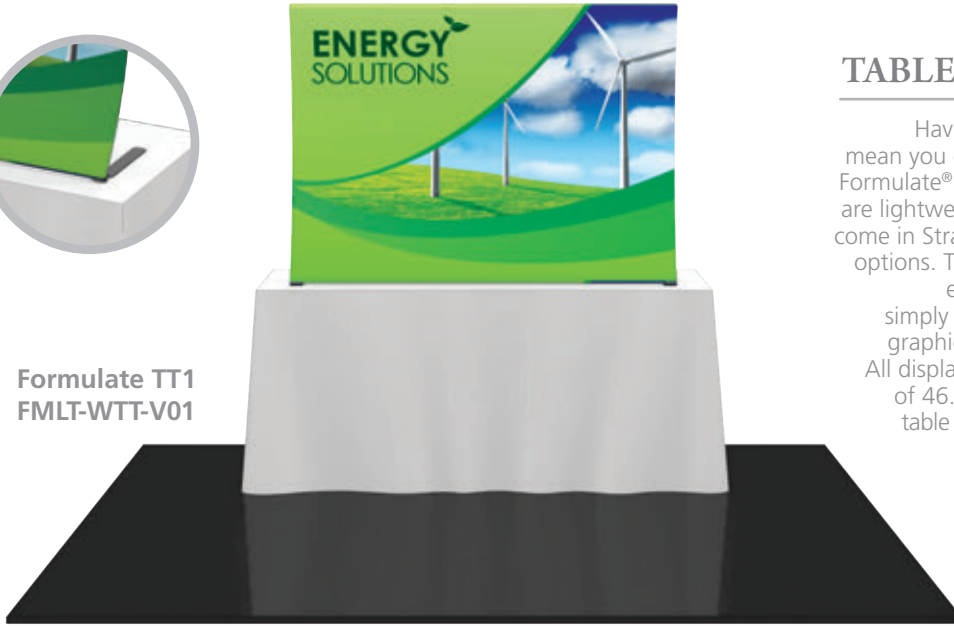

**FORMULATE**  
**TABLETOP DISPLAYS**

Having a small space doesn't mean you can't make a big impact! Formulate® Master Tabletop displays are lightweight, highly-portable and come in Straight and Vertical Curved options. The frame assembles with easy-to-use snap buttons; simply pull the pillowcase fabric graphic over the frame and zip. All displays have an overall height of 46.5 inches, fit on a 6' wide table and come in a convenient transit case.

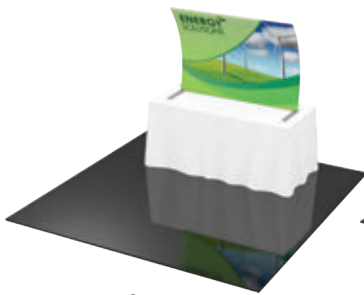

**Formulate TT2**  
FMLT-WTT-V02

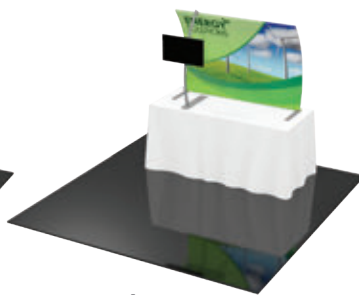

**Formulate TT3**  
FMLT-WTT-V03

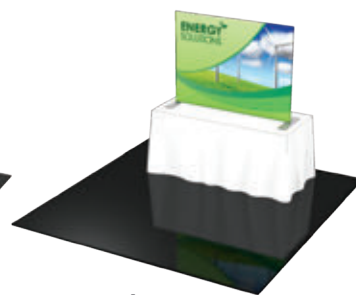

**Formulate TT4**  
FMLT-WTT-S01

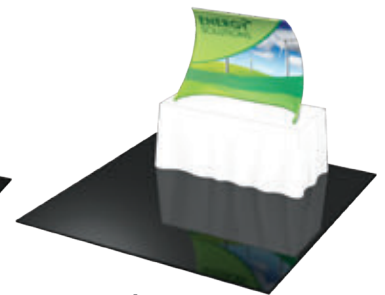

**Formulate TT5**  
FMLT-WTT-S02



**CLAMP**  
UC-FMLT



**TABLET HOLDER**  
UC-VESA-BRKT-01



**LIT HOLDER BRACKET**  
UC-LIT-BRKT-ABH-02  
UC-LIT-BRKT-ABH-03



**SHELF BRACKET**  
UC-SHLF-BRKT-01-CIR  
UC-SHLF-BRKT-02-TRI  
UC-SHLF-BRKT-03-SQU

**FORMULATE**  
**UNIVERSAL**  
**CONNECTORS**  
**& ACCESSORIES**

The Formulate Universal Accessory system is designed to give you the freedom to add and change your accessories when you need to. Using a clamp that fits into the tube, easily attach a literature holder, shelf or iPad holder.



Formulate Lite and Master displays come with a portable carry bag or case and a limited lifetime hardware warranty.

# FORMULATE® MASTER | 10' VERTICAL CURVED DISPLAYS

## FORMULATE MASTER 10' VERTICAL CURVED DISPLAYS

Slightly arched from top to bottom, Formulate® Master 10' Vertical Curved exhibits combine pillowcase fabric graphics with lightweight aluminum tube frames to form fashionable and functional exhibits. Accessories such as headers, adjustable literature holders, tables and accents provide enhanced functionality and more real estate for messaging. The wide array of Formulate Master Vertical Curved kits and accessories make it easy to glamorize any 10' space.



Formulate VC10  
FMLT-WV10-10



Courtesy of: CamelbackDisplays.com



Courtesy of:  
Motif Events



Courtesy of: Worldwide  
Graphics & Sign Company

# 10' VERTICAL CURVED DISPLAYS | FORMULATE® MASTER



Formulate VC1  
FMLT-WV10-01



Formulate VC2  
FMLT-WV10-02



Formulate VC3  
FMLT-WV10-03



Formulate VC4  
FMLT-WV10-04



Formulate VC5  
FMLT-WV10-05



Formulate VC6\*  
FMLT-WV10-06



Formulate VC7\*  
FMLT-WV10-07



Formulate VC8\*  
FMLT-WV10-08



Formulate VC9\*  
FMLT-WV10-09



Formulate VC11  
FMLT-WV10-11

\*Monitors not included.



Formulate Master displays come with a portable carry bag or case and a limited lifetime hardware warranty.

# FORMULATE® MASTER | 10' HORIZONTAL CURVED DISPLAYS

## FORMULATE MASTER 10' HORIZONTAL CURVED DISPLAYS

Ergonomically designed, Formulate® Master 10' Horizontal Curved exhibits combine the latest developments in fabric printed technology with a gently curved aluminum frame to create a seamless, elegant exhibit that enhances the message of your exhibit or environment. Accents provide added functionality and messaging areas. With so many choices, you're sure to find a design that suits your desire for style!



Formulate HC6\*  
FMLT-WH10-06



Formulate HC1



Formulate HC2



Courtesy of: Hanscom  
Federal Credit Union

FORMULATE MASTER | 10' HORIZONTAL CURVED DISPLAYS

10' HORIZONTAL CURVED DISPLAYS | FORMULATE® MASTER



Formulate HC1  
FMLT-WH10-01



Formulate HC2  
FMLT-WH10-02

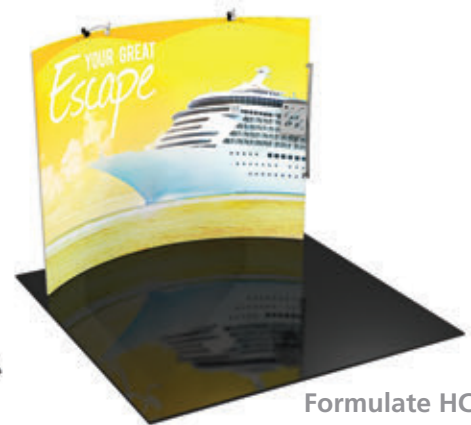

Formulate HC3  
FMLT-WH10-03



Formulate HC4  
FMLT-WH10-04



Formulate HC5  
FMLT-WH10-05



Formulate HC7\*  
FMLT-WH10-07



Formulate HC8\*  
FMLT-WH10-08



Formulate HC9  
FMLT-WH10-09



Formulate HC10  
FMLT-WH10-10

FORMULATE MASTER | 10' HORIZONTAL CURVED DISPLAYS



\*Monitors not included.

Formulate Master displays come with a portable carry bag or case and a limited lifetime hardware warranty.

# FORMULATE® MASTER | 10' STRAIGHT DISPLAYS

## FORMULATE MASTER 10' STRAIGHT DISPLAYS

Space maximizing Formulate® Master 10' Straight exhibits incorporate sleek, straight aluminum frames with zipper pillowcase fabric graphics to create a sharp, bold backwall that clearly conveys who you are and what you do. With a variety of accents including graphic headers, adjustable literature pockets, shelves, tables, counters and more, you are sure to find a design that best suits your space needs!



Formulate S5  
FMLT-WS10-05



Formulate S1  
FMLT-WS10-01



Formulate S2  
FMLT-WS10-02



Formulate S3  
FMLT-WS10-03



Formulate S4  
FMLT-WS10-04



Formulate S6  
FMLT-WS10-06



Formulate S7  
FMLT-WS10-07



Formulate Master displays come with a portable carry bag or case and a limited lifetime hardware warranty.

FORMULATE MASTER ACCENTS

Formulate® Master Accents enhance the functionality of most Formulate Master 10' and 20' backwalls and add more real estate for messaging too! With monitor supports, literature pockets, shelves, tables, counters and more, you are sure to find the accent that best suits your needs. Side tables and graphic headers also available.

FORMULATE  
BACKWALL CONNECTOR  
FMLT-WBWC

The Formulate® Master Backwall Connector is an ideal accessory to connect two 10' or 20' Formulate backwalls. It features a pillowcase fabric graphic and connects easily to create the appearance of one seamless display.

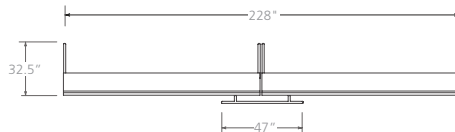

CONNECTOR 02  
FMLT-WBWC-02

Pillowcase fabric graphic

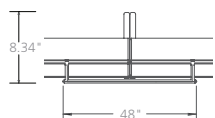

CONNECTOR 03  
FMLT-WBWC-03\*

Pillowcase fabric graphic and monitor mounts for a medium sized monitor\*

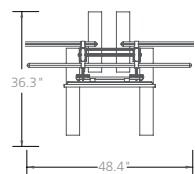

CONNECTOR 04  
FMLT-WBWC-04

Pillowcase fabric graphic

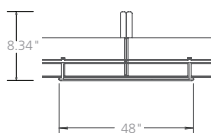

CONNECTOR 05  
FMLT-WBWC-05\*

Pillowcase fabric graphic and monitor mounts for a medium sized monitor\*

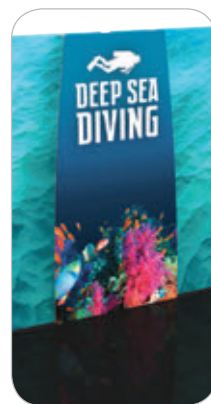
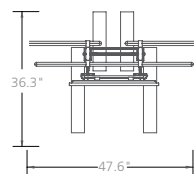

CONNECTOR 06  
FMLT-WBWC-06

Pillowcase fabric graphic

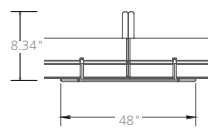

CONNECTOR 07  
FMLT-WBWC-07\*

Pillowcase fabric graphic and monitor mount for a medium sized monitor\*

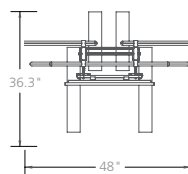

\*Monitors not included.

# FORMULATE® MASTER | ACCENTS

## FORMULATE MASTER ACCENTS

Formulate® Master Accents enhance the functionality of many Formulate Master 10' and 20' backwalls and add more real estate for messaging too! With monitor supports, literature pockets, shelves, tables, counters and more, you are sure to find the accent that best suits your needs. Side tables and graphic headers also available.

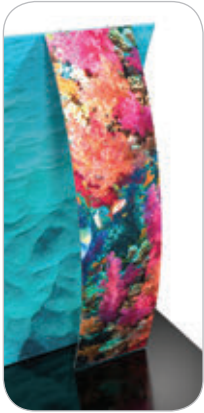

**ACCENT 01**  
FMLT-WL01

Pillowcase fabric graphic



**ACCENT 02**  
FMLT-WL02

Three 20" w shelves and top and bottom printed infill panels



**ACCENT 03**  
FMLT-WL03/ -L, -R\*

Choice of right-hand or left-hand arm tables, no table, top and bottom printed infill panels; fits a medium sized monitor\*



**ACCENT 04**  
FMLT-WL04\*

Features a 36" w table top, top and bottom velcro applied printed fabric graphics and hardware mounts for a medium sized monitor\*



**ACCENT 05**  
FMLT-WLLH

Three literature pockets, and top and bottom printed infill panels



**ACCENT 06**  
FMLT-WLC

Features a 20" w shelf and top and bottom printed infill panels



Accent 02, 03, 03-R, 03-L & 06 are also available for rent



**ACCENT 07**  
FMLT-WL07

Two 30" w shelves and a 36" w fabric counter adds space for small products to be displayed with style

**ACCENT 08**  
FMLT-WL08

A 36" w rectangular graphic accent adds ample space for additional messaging; a wooden base in your choice of color provides stability

**ACCENT 09**  
FMLT-WL09

A sleek trapezoidal shaped graphic adds additional real estate for branding and messages



\*Monitors not included.

Formulate Master accents are made in North America, come with a portable case and a limited lifetime hardware warranty.



FORMULATE MASTER ACCENTS



**ACCENT 10**  
FMLT-WL10\*

The multi-purpose accent features a 36" w shelf, fabric graphic and medium monitor mount for demonstrations

**ACCENT 11**  
FMLT-WL11

A uniquely designed triangular shaped wall offers two shelves to display small products

**ACCENT 12**  
FMLT-WL12\*

A dimensional pillowcase fabric graphic adds space for messaging; three 18.5" w shelves provide space to display products and a small monitor mount allows for presentations



**ACCENT 13**  
FMLT-WL13

This 36" w S-shaped fabric graphic accent adds dimension and accessorizes a Formulate backwall

**ACCENT 14**  
FMLT-WL14

Make a bold statement to compliment your backwall with this 52" w graphic wall; perfect to add company branding and messaging

**ACCENT 15**  
FMLT-WL15

Display company literature with style! Featuring a 18" w pillowcase fabric graphic and three literature holders



\*Monitors not included.

Formulate Master accents are made in North America, come with portable cases and a limited lifetime hardware warranty.

## FORMULATE MASTER ACCENTS

Formulate® Master Accents enhance the functionality of the Formulate Master 20' Straight backwall and add more real estate for messaging too!



### BACKWALL ACCENT 01 FMLT-WBWA-01

- 232" w x 57.46" h x 9.22" d
- curved pillowcase fabric graphic attaches to a Formulate 20' Straight Master backwall

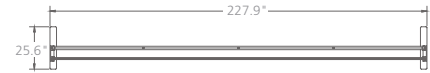

### BACKWALL ACCENT 02 FMLT-WBWA-02

- 232" w x 45.83" h x 9.22" d
- slanted pillowcase fabric graphic attaches to a Formulate 20' Straight Master backwall



### BACKWALL ACCENT 03 FMLT-WBWA-03

- 232" w x 45.78" h x 9.22" d
- pillowcase fabric graphic attaches to a Formulate 20' Straight Master backwall



FORMULATE MASTER ACCENTS

**BACKWALL ACCENT 04**  
 (straight) FMLT-WBWA-04S-L/-R  
 (curved) FMLT-WBWA-04C-L/-R

- (straight) 39.37" w x 35.43" h x 114.41" d
- (curved) 59.06" w x 35.43" h x 114.41" d
- L-shaped pillowcase divider walls attach to any Formulate Master Straight backwall

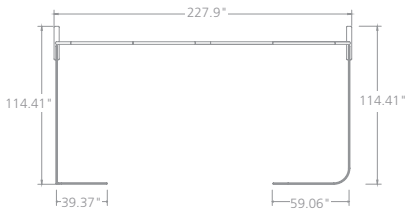

**BACKWALL ACCENT 05**  
 FMLT-WBWA-05

- 51.82" w x 96.87" h x 103.65" d
- L-shaped pillowcase fabric graphic attaches to any Formulate Master Straight style backwall
- 48.82" w tabletop included on interior of accent

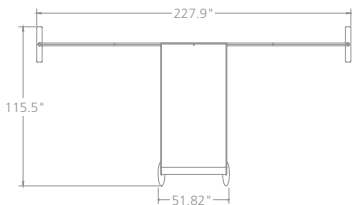

*\* only for use in peninsula or island tradeshow spaces*

**BACKWALL ACCENT 06**  
 FMLT-WBWA-06

- 51.9" w x 98.99" h x 107.47" d
- one straight and one curved panel connect and attach to any Formulate Master Straight style backwall
- 44.94" w x 41.18" h x 14" d laminate counter included on interior of accent provides lockable storage

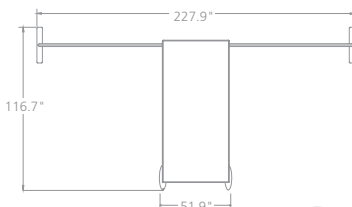

*\* only for use in peninsula or island tradeshow spaces*



Formulate Master accents are made in North America, come with portable cases and a limited lifetime hardware warranty.

# FORMULATE® MASTER | 20' SERPENTINE CURVED DISPLAYS

## FORMULATE MASTER 20' SERPENTINE CURVED DISPLAYS

The gentle and organic S-shaped curves of the Formulate® Master Serpentine line of 20' exhibits create an elegant flow within a space. These displays can feature a single or double sided fabric graphic, which provides more real estate for branding and messaging. Pillowcase style fabric graphics are coupled with sturdy, yet lightweight aluminum frames to create the unique and flowing Serpentine shape. Accents provide shelving, surface areas, monitor displays and additional messaging areas.



Formulate SC2\*  
FMLT-WSC-20-02

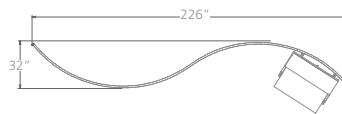
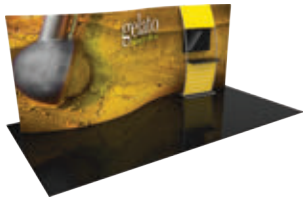

Formulate SC1



Courtesy of:  
Hamilton Exhibits

20' SERPENTINE CURVED DISPLAYS | **FORMULATE® MASTER**



**Formulate SC1**  
FMLT-WSC20-01

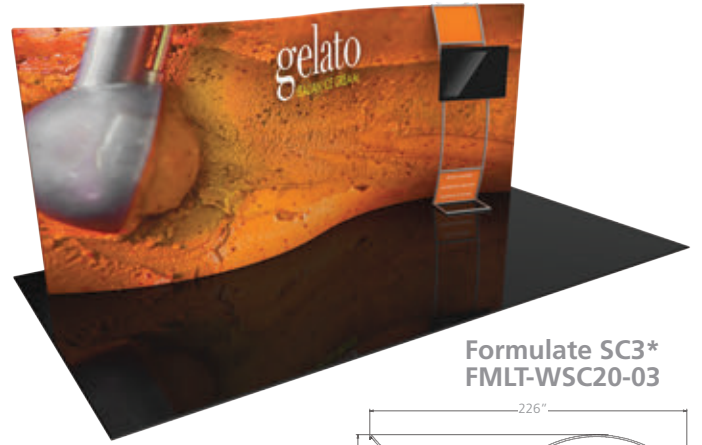
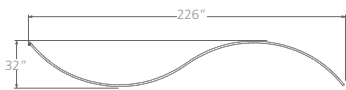

**Formulate SC3\***  
FMLT-WSC20-03

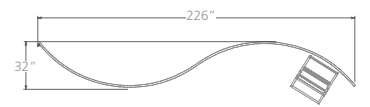

**Formulate SC4\***  
FMLT-WSC20-04

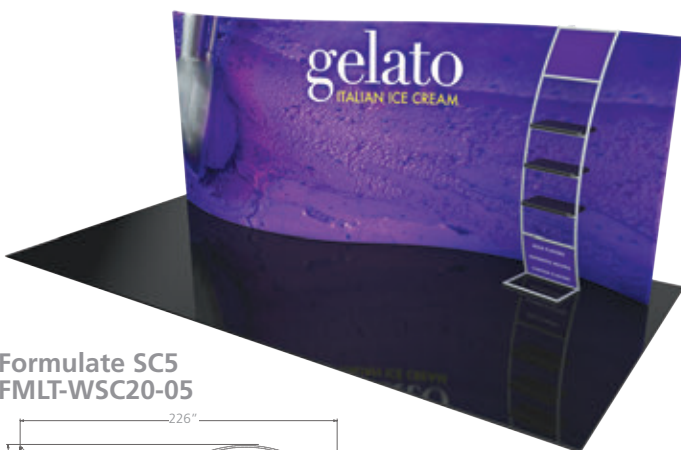
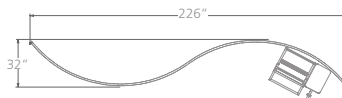

**Formulate SC5**  
FMLT-WSC20-05

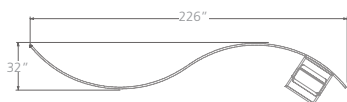

**Formulate SC6**  
FMLT-WSC20-06

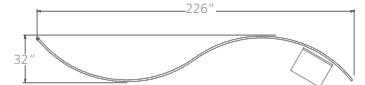

\*Monitors not included.

Formulate Master accents are made in North America, come with portable cases and a limited lifetime hardware warranty.

# FORMULATE® MASTER | 20' VERTICAL CURVED DISPLAYS

## FORMULATE MASTER 20' VERTICAL CURVED DISPLAYS

Slightly arched from top to bottom, Formulate® Master 20' Vertical Curved displays combine pillowcase fabric graphics with lightweight aluminum tube frames to form fashionable and functional exhibits. Accents provide enhanced functionality and more real estate for messaging. The wide array of Formulate Master Vertical Curved kits and accessories make it easy to glamorize any 20' space. Easily convert the 20' Master Vertical Curve Formulate to a 10' backwall with the purchase of a 10' graphic. No additional hardware needed.



Formulate WV3\*  
FMLT-WV20-03

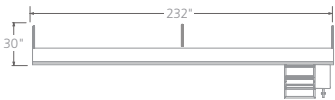

*easily converts to  
a 10' backwall*



10' Vertical  
Curved Backwall

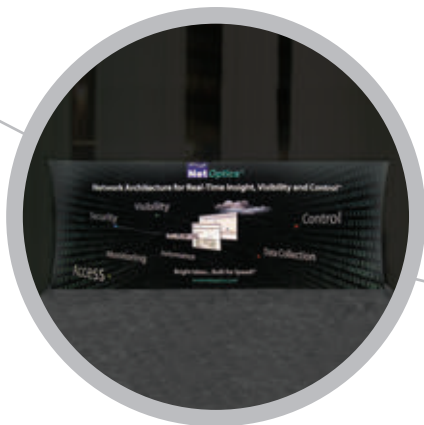

Courtesy of: Eco Exhibits/  
Advantum Displays



Courtesy of: Eye  
Catching Solutions

# 20' VERTICAL CURVED DISPLAYS | FORMULATE® MASTER



Formulate WV1  
FMLT-WV20-01



Formulate WV2\*  
FMLT-WV20-02



Formulate WV4  
FMLT-WV20-04



Formulate WV5  
FMLT-WV20-05



FORMULATE MASTER | 20' VERTICAL CURVED DISPLAYS



\*Monitors not included.

Formulate Master accents are made in North America, come with portable cases and a limited lifetime hardware warranty.

# FORMULATE® MASTER | 20' HORIZONTAL CURVED DISPLAYS

## FORMULATE MASTER 20' HORIZONTAL CURVED DISPLAYS

Ergonomically designed, Formulate® 20' Master Horizontal Curved exhibit kits combine the latest developments in fabric printed technology with a gently curved aluminum frame to create a seamless, elegant exhibit that enhances the message of your exhibit or environment. Accents provide added functionality and messaging areas. With so many choices, you're sure to find a design that suits your desire for style! Easily convert the 20' Master Horizontal Curve Formulate to a 10' backwall with the purchase of a 10' graphic. No additional hardware needed.



Formulate WH4\*  
FMLT-WH20-04



easily converts to  
a 10' backwall



10' Horizontal  
Curved Backwall

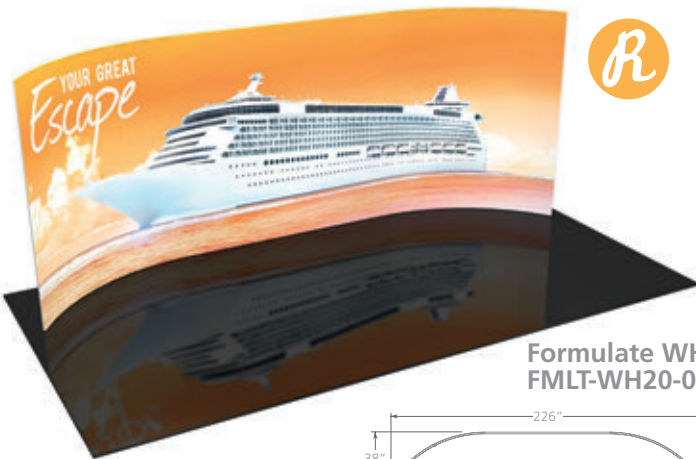

Formulate WH1  
FMLT-WH20-01

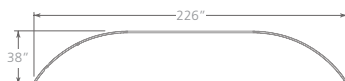

Formulate WH2\*  
FMLT-WH20-02

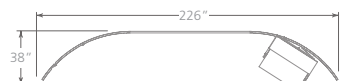

\*Monitors not included.





**Formulate WH3\***  
FMLT-WH20-03



**Formulate WH5**  
FMLT-WH20-05



**Formulate WH6**  
FMLT-WH20-06

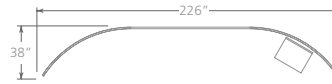

**Formulate 20 Straight**  
FMLT-WS20-30MM-01



### FORMULATE MASTER 20' STRAIGHT DISPLAY

The Formulate® 20' Master Straight backwall incorporates a sleek, straight aluminum frame with a zipper pillowcase fabric graphic to create a sharp, bold backwall that clearly conveys who you are and what you do. Print on just one side or on both sides of the graphic to maximize your message and brand exposure!



\*Monitors not included.

Formulate Master accents are made in North America, come with portable cases and a limited lifetime hardware warranty.

# FORMULATE® DESIGNER SERIES | 10' DISPLAYS

## FORMULATE DESIGNER SERIES 10' DISPLAYS

Formulate® Designer Series exhibits and structures feature unique stylistic elements, making them modern and sophisticated in style. Formulate Designer Series structures couple lightweight aluminum frames with push-fit and zipper pillowcase fabric graphics. Formulate Designer Series fabric structures are formed with expert aluminum bending machinery and skilled welding and metal-working technicians.



FORMULATE DESIGNER SERIES  
KIT 08  
FMLT-DS-10-08\*



FORMULATE DESIGNER SERIES | 10' DISPLAYS



Formulate Designer Series displays are made in North America, come with portable cases and a limited lifetime hardware warranty.

# 10' DISPLAYS | FORMULATE® DESIGNER SERIES

## FORMULATE DESIGNER SERIES 10' DISPLAYS

Formulate® Designer Series 10' displays have unique stylistic features and shapes, are portable and easy to assemble. The aluminum tube frame features snap-buttons and zipper pillowcase fabric graphics. All displays come in portable, wheeled transit cases. Simply pull the pillowcase fabric graphic over the frame and zip.



FMLT-DS-10-01\*

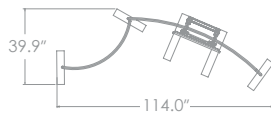

FMLT-DS-10-02

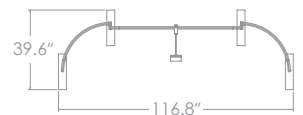

FMLT-DS-10-03

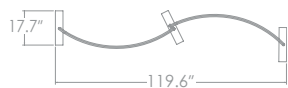

FMLT-DS-10-04



\*Monitors not included.

Formulate Designer Series displays are made in North America, come with portable cases and a limited lifetime hardware warranty.



# FORMULATE® DESIGNER SERIES | 10' DISPLAYS

## FORMULATE DESIGNER SERIES 10' DISPLAYS

Formulate® Designer Series 10' displays have unique stylistic features and shapes, are portable and easy to assemble. The aluminum tube frame features snap-buttons and zipper pillowcase fabric graphics. All displays come in portable, wheeled transit cases. Simply pull the pillowcase fabric graphic over the frame and zip.



FMLT-DS-10-05



FMLT-DS-10-06\*

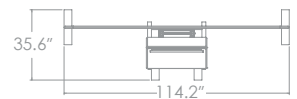

FMLT-DS-10-07\*

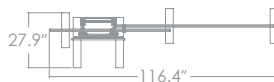

FMLT-DS-10-09\*

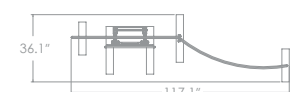

\*Monitors not included.

Formulate Designer Series displays are made in North America, come with portable cases and a limited lifetime hardware warranty.



# 10' DISPLAYS | FORMULATE® DESIGNER SERIES

FORMULATE DESIGNER SERIES  
10' DISPLAYS



FMLT-DS-10-10\*

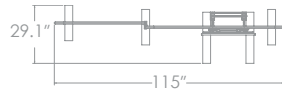

FMLT-DS-10-11\*



FMLT-DS-10-12

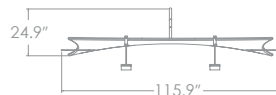

FMLT-DS-10-13



\*Monitors not included.

Formulate Designer Series displays are made in North America, come with portable cases and a limited lifetime hardware warranty.



# FORMULATE® DESIGNER SERIES | 20' DISPLAYS

## FORMULATE DESIGNER SERIES 20' DISPLAYS

Formulate® Designer Series 20' inline exhibits feature unique stylistic elements, making them modern and sophisticated in style. Formulate Designer Series structures couple lightweight aluminum frames with stretch, zipper pillowcase fabric graphics. Formulate Designer Series fabric structures are formed with expert aluminum bending machinery and skilled welding and metal-working technicians.



FMLT-DS-20-01

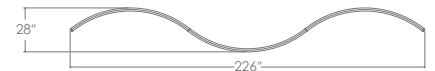

FMLT-DS-20-02

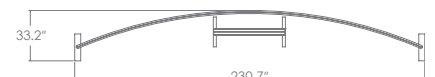

FORMULATE DESIGNER SERIES | 20' DISPLAYS



Formulate Designer Series displays are made in North America, come with portable cases and a limited lifetime hardware warranty.

20' DISPLAYS | **FORMULATE® DESIGNER SERIES**

FORMULATE DESIGNER SERIES  
20' DISPLAYS



FMLT-DS-20-03

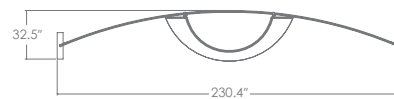

FMLT-DS-20-04



FMLT-DS-20-05\*

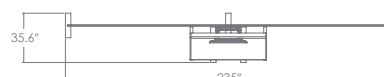

\*Monitors not included.



Formulate Designer Series displays are made in North America, come with portable cases and a limited lifetime hardware warranty.

# FORMULATE® DESIGNER SERIES | 20' DISPLAYS

## FORMULATE DESIGNER SERIES 20' DISPLAYS

Formulate® Designer Series 20' inline exhibits feature unique stylistic elements, making them modern and sophisticated in style. Formulate Designer Series structures couple lightweight aluminum frames with stretch, zipper pillowcase fabric graphics. Formulate Designer Series fabric structures are formed with expert aluminum bending machinery and skilled welding and metal-working technicians.

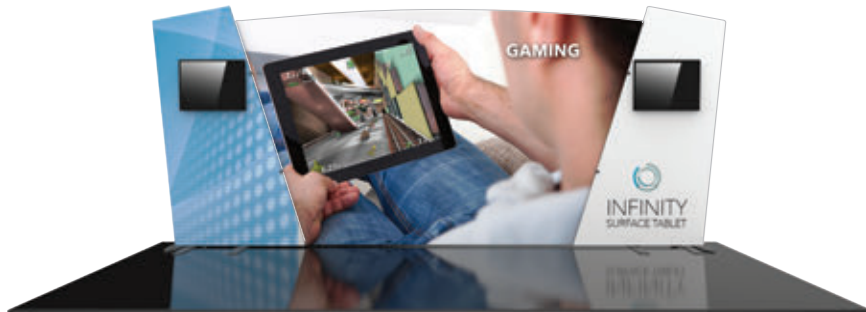

FMLT-DS-20-06\*



FMLT-DS-20-07\*



FMLT-DS-20-08\*



FMLT-DS-20-09



\*Monitors not included.

Formulate Designer Series displays are made in North America, come with portable cases and a limited lifetime hardware warranty.





# 20' DISPLAYS | FORMULATE® DESIGNER SERIES

## FORMULATE DESIGNER SERIES 20' DISPLAYS



FMLT-DS-20-10

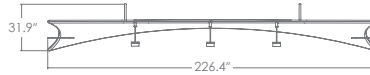

FMLT-DS-20-11\*

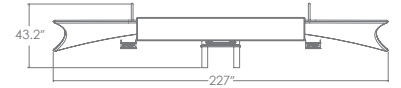

FMLT-DS-20-12\*



FMLT-DS-20-13\*



\*Monitors not included.

Formulate Designer Series displays are made in North America, come with portable cases and a limited lifetime hardware warranty.



# FORMULATE® DESIGNER SERIES | 30' DISPLAYS

## FORMULATE DESIGNER SERIES 30' DISPLAYS

Formulate® Designer Series 30' kits come in Straight, Straight Layered, Vertical Curve, Horizontal Curve and Serpentine Curve options. Formulate Designer Series 30' displays feature USA-made lightweight aluminum tube frames and pillowcase fabric graphics that simply slide over the frame and zip at the bottom.



FMLT-DS-30-01



FMLT-DS-30-02

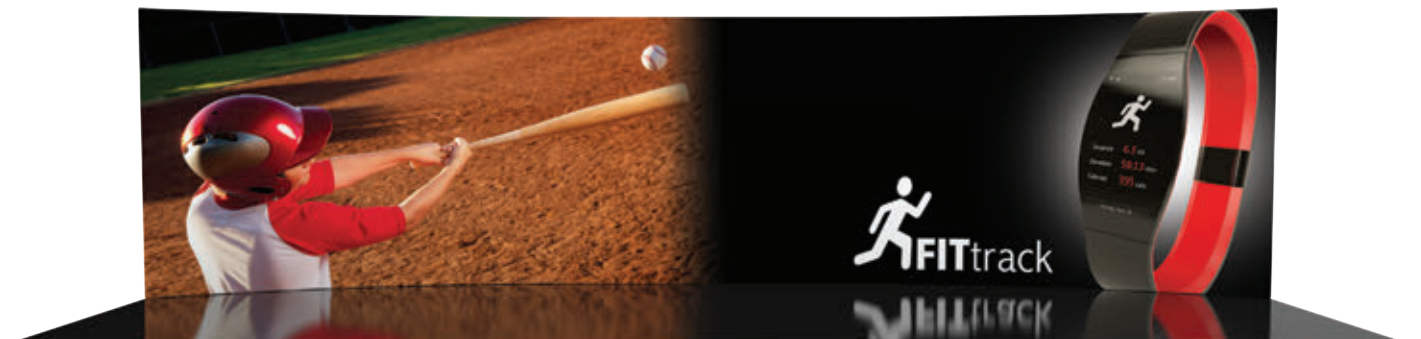
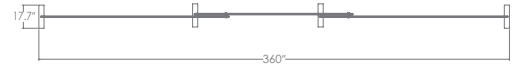

FMLT-DS-30-03



Formulate Designer Series displays are made in North America, come with portable cases and a limited lifetime hardware warranty.

30' DISPLAYS | **FORMULATE® DESIGNER SERIES**

FORMULATE DESIGNER SERIES  
30' DISPLAYS



FMLT-DS-30-04

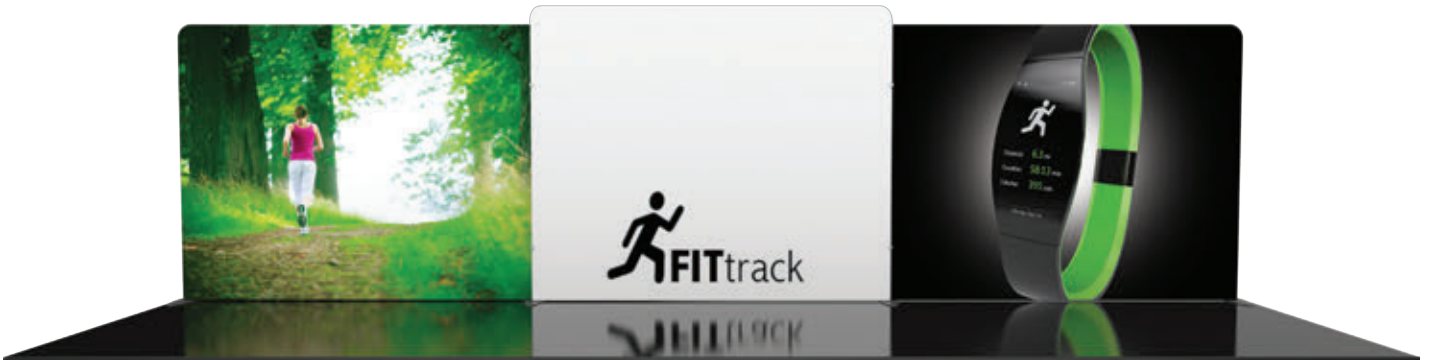

FMLT-DS-30-05



FMLT-DS-30-06

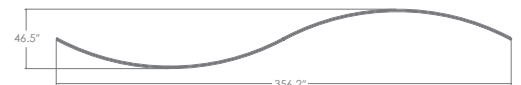

FORMULATE DESIGNER SERIES | 30' DISPLAYS



Formulate Designer Series displays are made in North America, come with portable cases and a limited lifetime hardware warranty.

# SPIN OR FLIP

TO CREATE A DIFFERENT LOOK  
& SHOW A NEW MESSAGE!

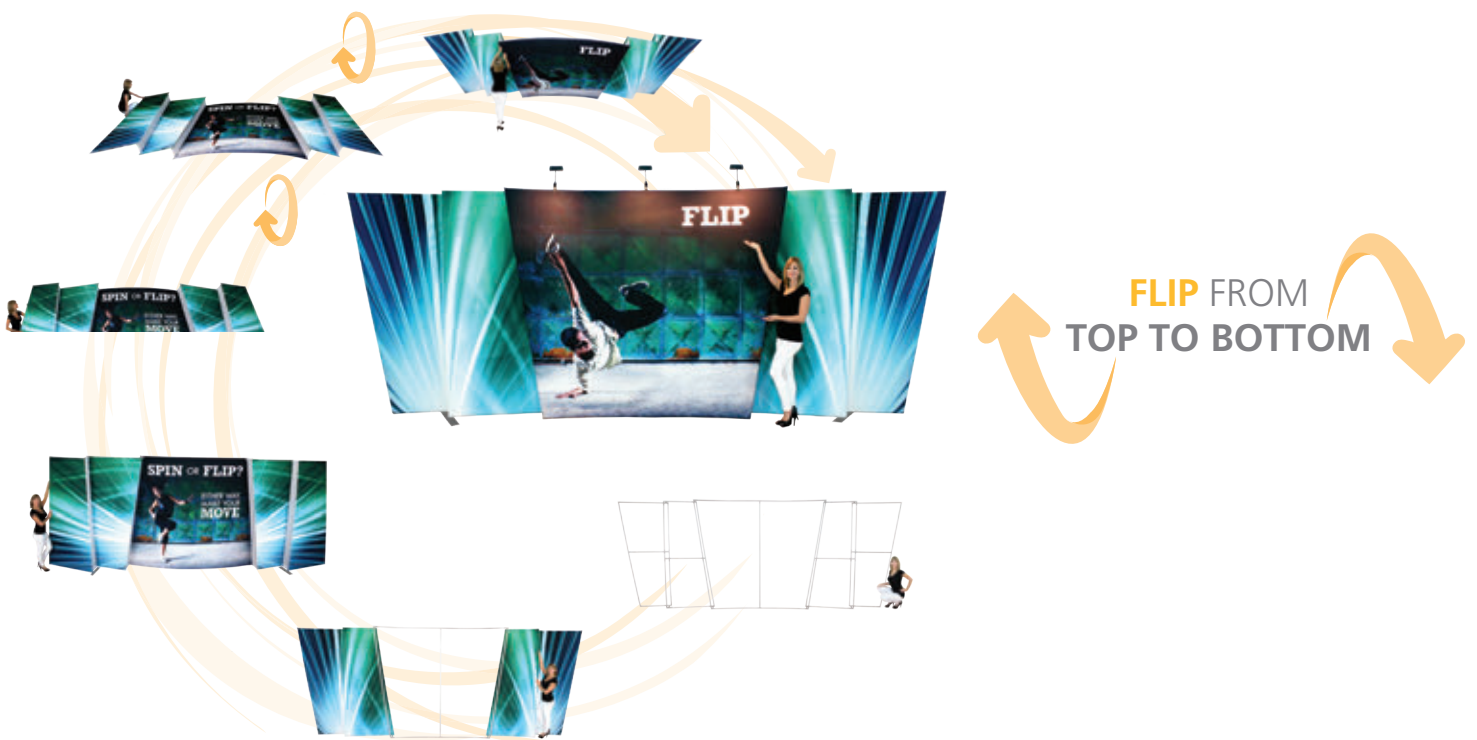
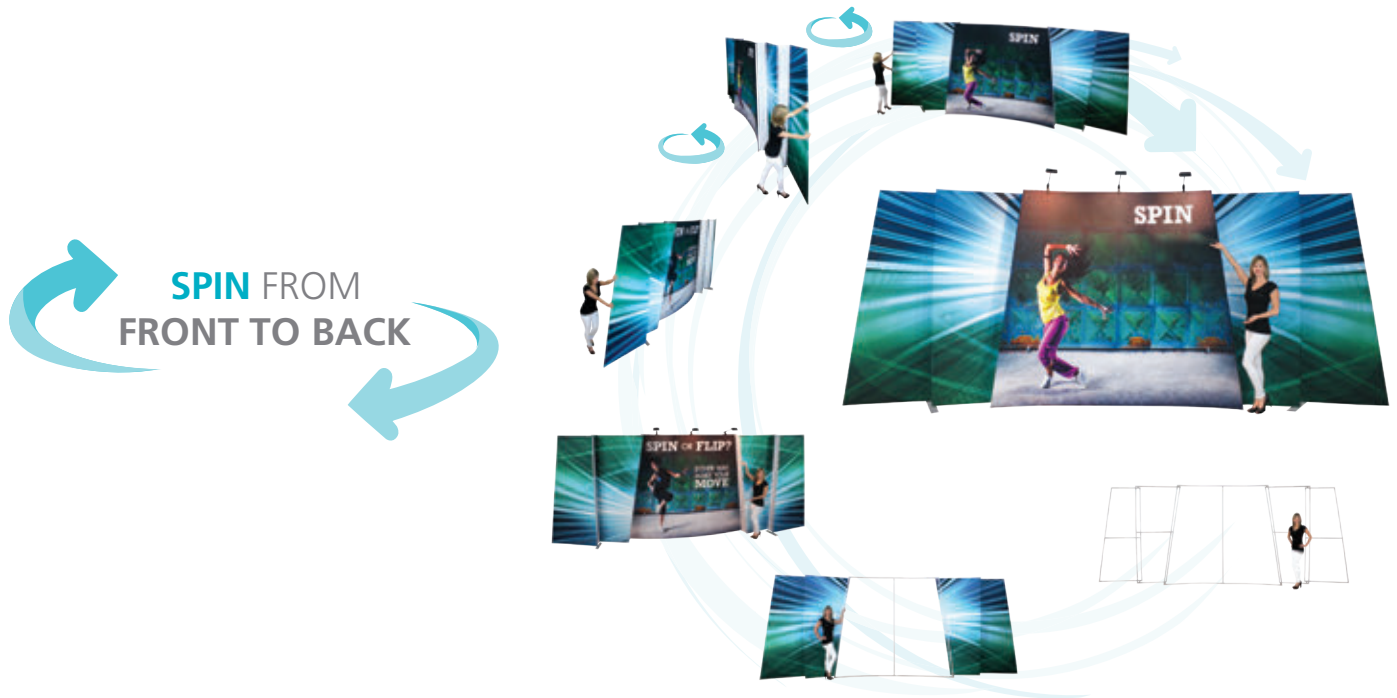

FLIP 20' EXHIBIT KITS

FLIP™ 20' exhibits incorporate layered, staggered walls that are connected to create a unique, dimensional and versatile display. Ask to incorporate LED lights to make your FLIP™ display shine.

SO FLIPPIN' COOL

Double sided graphics enable you to feature a different look, brand or messaging so you can **SPIN from front to back** OR use as a creative space divider for a larger space. With an easy graphic change, you can also **FLIP from top to bottom** to create a new, different exhibit and look for your next event.

SO FLIPPIN' EASY

FLIP kits combine 30mm lightweight aluminum frames with your choice of single or double sided zipper pillowcase fabric graphics. Simply join the aluminum tubes together with strong internal spigots, slide the fabric graphics over the frames, then zip. It's that easy.



FLIP-01

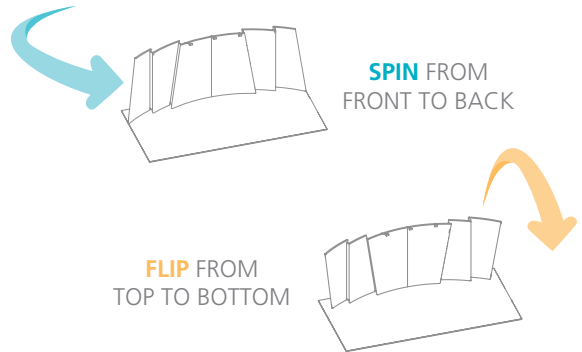

FLIP-03

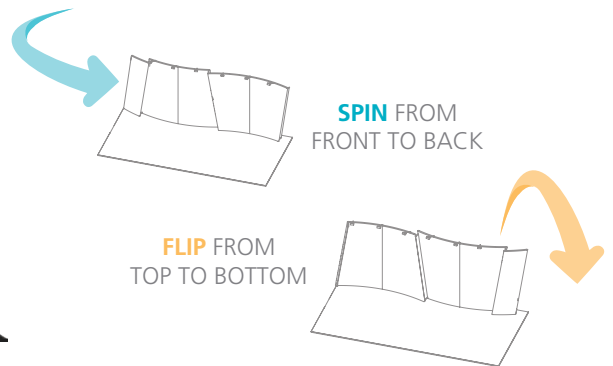

FLIP-04

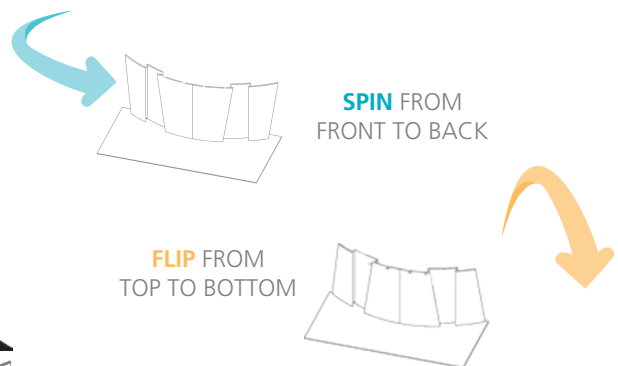

\*Counters, lighting and lighting hardware not included in kits. A la carte counter options presented on pages 130-131.

# FORMULATE® | VIBE™ 10' EXHIBIT KITS

## VIBE 10' EXHIBIT KITS

Vibe™ is a collection of cleverly-designed, dimensionally layered 10' exhibit kits. Vibe combines layered lightweight aluminum tube frames with zippered pillowcase printed fabric graphics. Unique shapes, angles and exposed framework create a truly unique appearance and experience. Where featured, kits include graphic headers, lights and monitor kiosks to provide additional branding and messaging areas.



KIT 05  
VBK-5



Vibe kits are made in North America, come with portable carry cases and a limited lifetime hardware warranty.



**KIT 01**  
VBK-1



**KIT 02**  
VBK-2



**KIT 03**  
VBK-3

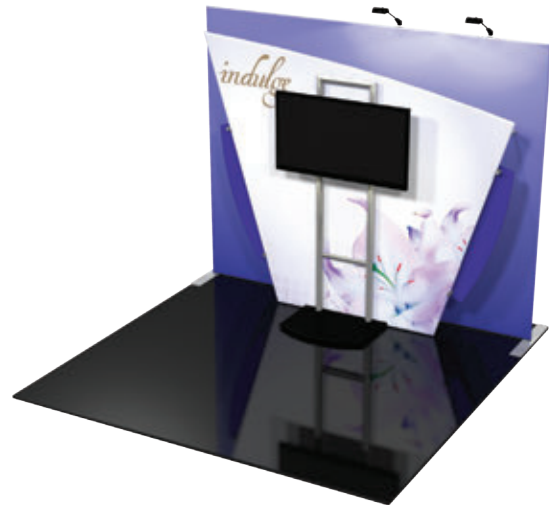
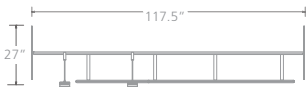

**KIT 06**  
VBK-6



**VIBE MONITOR  
KIOSK**

**VB-MK-01**

Simply add the Vibe™ kiosk to create an interactive, multimedia display. Kiosk comes with a monitor bracket that holds a max weight of 50 lbs and a convenient, portable shipping case. Monitor is not included with kiosk or kit.

# CUSTOM EXHIBIT SOLUTIONS



## SOLUTION STRATEGY

We help inspire, guide and manage your project from concept to completion and help transform your goals and objectives into a success-driven tradeshow strategy.



## EXHIBIT DESIGN

No matter what your company's needs, our exhibit designers approach each and every project as an "original", incorporating a wide range of aluminum extrusions, laminates, fabrics, media and graphics resulting in an exhibit that's uniquely yours.



## CUSTOM FABRICATION

From wood to fabrics, steel to alloys, plastics to glass, we create and build exhibits and displays out of all types of materials. These – coupled with state-of-the-art manufacturing facilities, printing technology and expert craftsmen – results in custom exhibits that are as unique and original as you and your brand.



## DISPLAY GRAPHICS

We unite wonderfully skilled craftspeople with cutting-edge print technologies and techniques to produce the highest quality display graphics and trade show graphics in the industry. Our high-quality graphics are matched to the G7® Master Print specification. This designation assures that every graphic we print will look exactly as our clients intended.



## LOGISTICS MANAGEMENT

We provide a wide array of trade show services designed to simplify the process and decisions you need to make. In every phase, we work to keep costs down while ensuring your display is taken excellent care of every step. Show up and we take care of the rest.



# CUSTOM ISLAND EXHIBITS



Rental Island 20' x 20'

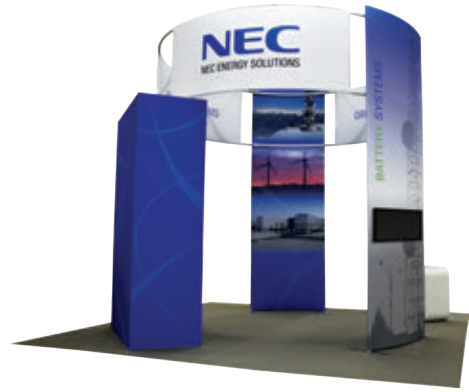

Custom Island 20' x 20'

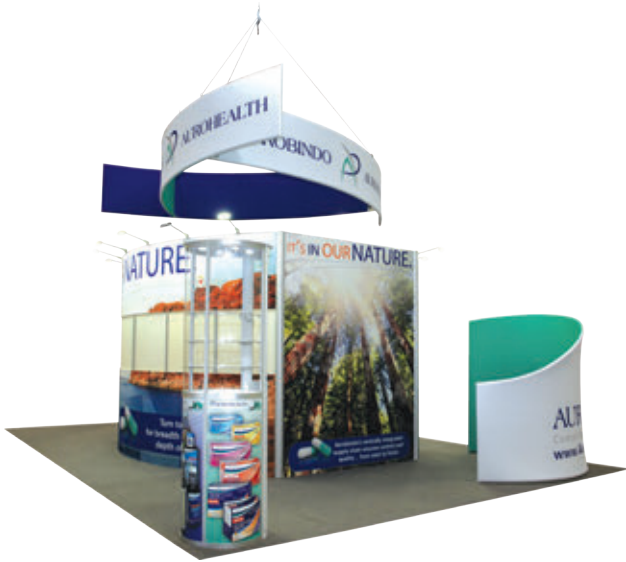

Custom Island 20' x 30'

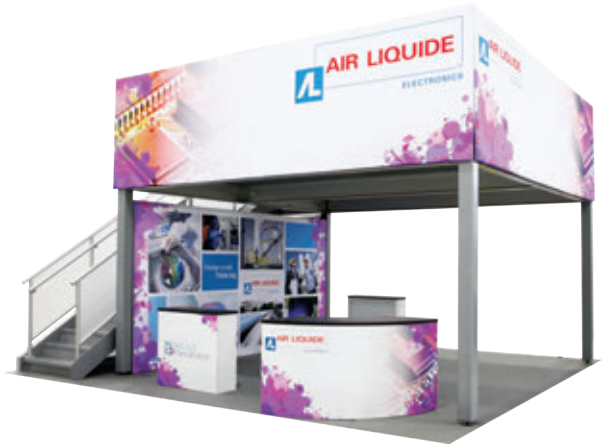

Rental Deck 20' x 30'



Custom Island 40' x 40'



Custom Island 40' x 100'

**FORMULATE FUSION KIT 05**  
CFAB-K-05



- Fabric covered tower centerpiece, zippered white fabric columns, laminate counter, three monitor mounts\* and 1 woodcrate
- Combines 50mm aluminum tubing w/ heavy-duty spigot connectors with state-of-the-art zipper pillowcase dye-sublimated fabric graphics
- Laminate counter with UV printed slat walls provides a welcoming reception area and lockable storage

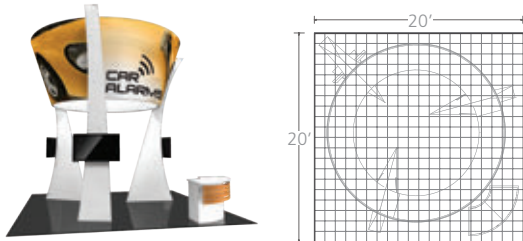

**FORMULATE FUSION KIT 06**  
CFAB-K-06

- Fabric center tower structure, two side fabric tower structures, rigid graphic accents, chip wall conference wall, oval counter, six monitor mounts\* and 1 woodcrate
- Combines 50mm aluminum tubing w/ heavy-duty spigot connectors with state-of-the-art zipper pillowcase dye-sublimated fabric graphics

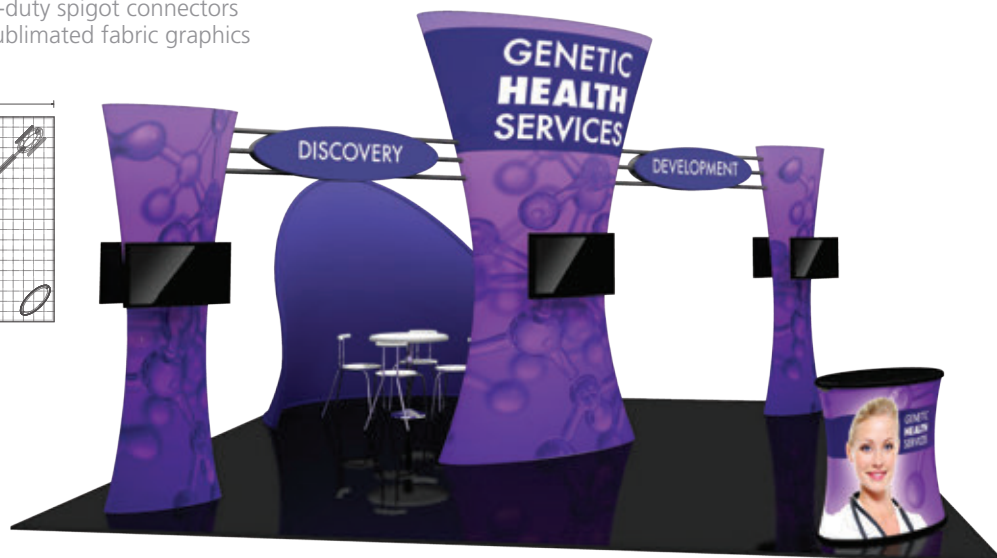
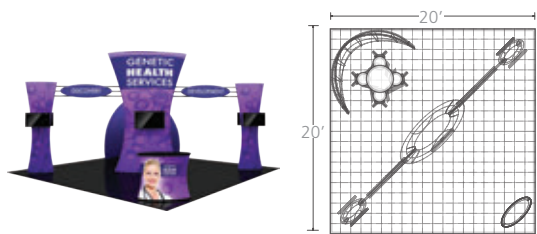

\*Monitors not included.

Formulate Fusion Kits are made in North America and have a limited lifetime hardware warranty.

## FORMULATE FUSION KIT 07

CFAB-K-07

- Aluminum tube frames and dye-sublimated zipper pillowcase fabric graphics for the two arch structures, three fabric accents in between arches, six shelves, two monitor mounts\* and 1 WOODCRATE-H
- Combines state-of-the-art zipper pillowcase dye-sublimated fabric graphics with advanced lightweight aluminum tubing

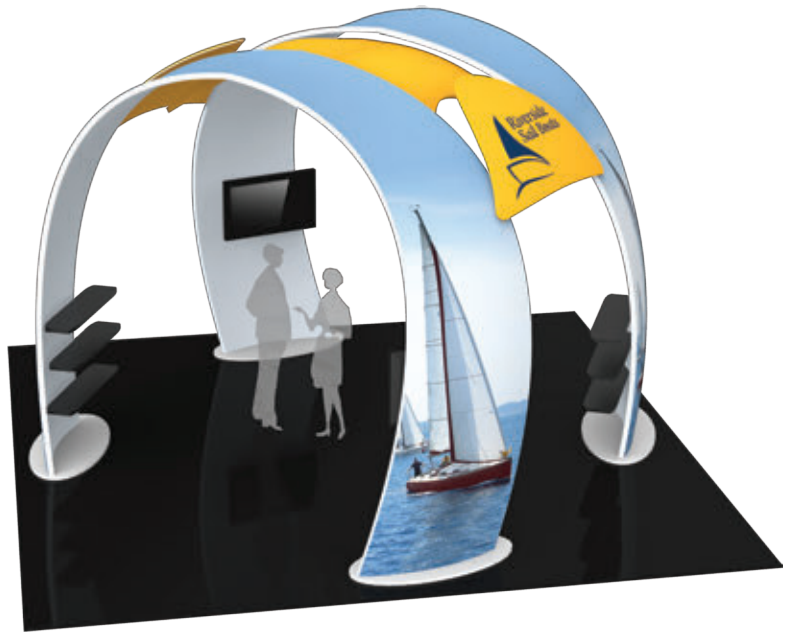
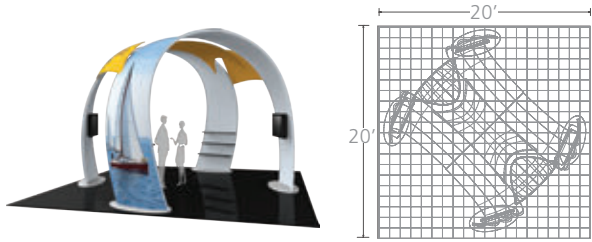

## FORMULATE FUSION KIT 08

CFAB-K-08

- Lightweight, aluminum tube frames and dye-sublimated zipper pillowcase fabric graphics for the backlit arch structure and four accent graphics
- Structural illuminated accents are 42" W x 105" H and feature three 29.5" illuminated squares each
- Tubular/fabric conference room
- Oval counter

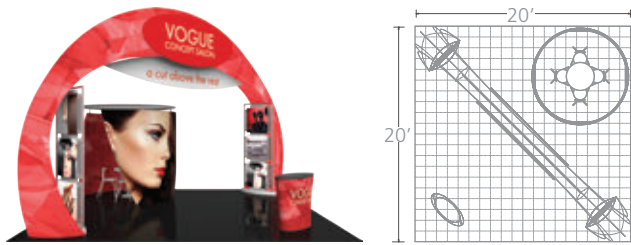

\*Monitors not included.

Formulate Fusion Kits are made in North America and have a limited lifetime hardware warranty.

**FORMULATE FUSION KIT 09**

**CFAB-K-09**

- Combines state-of-the-art zipper pillowcase dye-sublimated fabric graphics with advanced lightweight aluminum tubing
- L-shaped structure features a roof-top that extends 18' into exhibit space
- Structurally supported by laminated counter and anchors to two accent walls
- Two double-sided fabric graphic walls set at a 45 degree angle

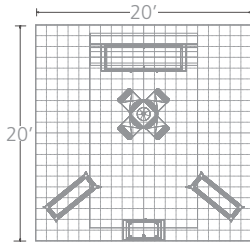

**FORMULATE FUSION KIT 10**

**CFAB-K-10**

- Combines state-of-the-art zipper pillowcase dye-sublimated fabric graphics with advanced lightweight aluminum tubing
- Rounded corner 16' square hanging structure; requires rigging
- Four 10' tall, 5' wide towers anchor to each corner
- Each tower includes two medium monitor mounts\* which hold 40"-50" monitors
- Semi-private fabric meeting space
- Freestanding pillar-shaped fabric counter

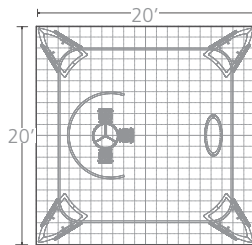

\*Monitors & furniture not included.  
Formulate Fusion Kits are made in North America and have a limited lifetime hardware warranty.

## FORMULATE FUSION KIT 11 CFAB-K-11

- Trapezoidal-shaped fabric structure hangs above four mirrored trapezoidal-shaped corner towers
- Four wood counters stand in front of towers
- Above each of the four towers are areas for large TV monitors; monitor mounts\* included
- Two L-shaped fabric dividers for semi-private meetings
- Hanging structure requires rigging

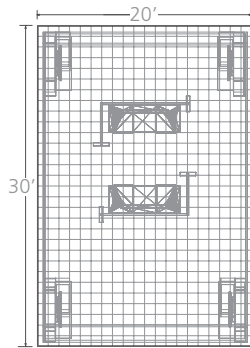
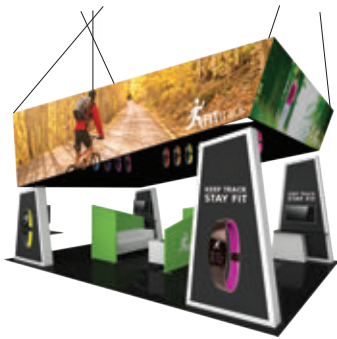

WHETHER YOU ARE LOOKING FOR IDEAS, AN OFF-THE-SHELF ISLAND DISPLAY TO SAVE TIME OR WANT A COMPLETELY CUSTOMIZED DESIGN, WE CAN HELP. WE DELIVER UNIQUE, MODERN AND FUNCTIONAL EXHIBITS THAT HELP YOU ACHIEVE YOUR FACE TO FACE TRADESHOW GOALS.



# FORMULATE® | TENSION FABRIC COUNTERS



## FORMULATE COUNTERS

Formulate® counters couple lightweight hardware with state-of-the-art printed stretch silicone edge push-fit fabric graphics to create funky and functional reception stands.



**PILLAR**  
W-01-C



**HALF MOON**  
W-02-C



**ELLIPSE**  
W-03-C



**BULLET**  
W-04-C



**OVAL**  
W-05-C



**BAR**  
W-06-C-04



HALF MOON



ILLUMINATED OVAL



BULLET

SYMPHONY™ COUNTERS

Symphony™ counters provide a unique, sleek design that lends an attractive element to any trade show or POP display. Symphony counters combine extrusion-based hardware with state-of-the-art PRINTED or SOLID COLOR stretch push-fit fabric graphics.



**OVAL**  
SYM-OV



**RECTANGLE**  
SYM-RCT



**BULLET**  
SYM-BLLT



**OVAL DOUBLE GRAND**  
SYM-OV-DBL-GRND



**3 QUAD KIT**  
SYM-QD-3

tension fabric counter tops are available in your choice of finishes



silver black mahogany natural

counter stretch skirts are available in custom printed options as well as the following colors:



amethyst ruby sapphire emerald silver jet



HALF MOON



HALF MOON



HALF MOON

FORMULATE CHARGING STATIONS



Formulate® Charging Stations add technology and great value for visitors in need of a quick charge. Excellent for retail applications, trade shows and events.

**CHARGING TOWER**  
FMLT-CHRG-01

- 33.56" w x 86.81" h x 33.46" d
- features 16 high-speed charging tips: (8) Micro USB for Android devices and (8) Apple 8-pin for Apple iPhone/iPad/ Lightning devices
- features a circular fabric header for branding and an illuminated fabric center structure
- base and tabletop color offered in choice of four thermoform color options



**CHARGING COUNTER**  
FMLT-CHRG-COUNTER-01

- 23.72" w x 41.54" h x 23.62" d
- features 8 high-speed charging tips: (4) Micro USB for Android devices and (4) Apple 8-pin for Apple iPhone/iPad/ Lightning devices
- features stretch fabric graphic
- tabletop offered in choice of four thermoform color options



TENSION FABRIC IPAD STANDS

Are you looking to incorporate iPads into your display or environment? Sleekly designed free-standing iPad stands and kiosks make it easy to encourage interactivity, present information and engage your customers in any space. Stands feature stretch fabric graphics.



**IPAD STAND 01**  
TABLET-STD-01

- 30" w x 84" h x 23" d
- small monitor mount\*, holds 32" TV/32lbs max
- iPad holder (2<sup>nd</sup>, 3<sup>rd</sup>, 4<sup>th</sup> gen and Air models)\*
- pillowcase fabric graphic



**IPAD STAND 02**  
TABLET-STD-02

- 20.25" w x 85.11" h x 23.8" d
- iPad holder (2<sup>nd</sup>, 3<sup>rd</sup>, 4<sup>th</sup> gen and Air models)\*
- pillowcase fabric graphic



**IPAD STAND 03**  
TABLET-STD-03

- 19.98" w x 64.34" h x 15.2" d
- iPad holder (2<sup>nd</sup>, 3<sup>rd</sup>, 4<sup>th</sup> gen and Air models)\*
- pillowcase fabric graphic



**IPAD STAND 04**  
TABLET-STD-04

- 26.26" w x 46.26" h x 22.64" d
- iPad holder (2<sup>nd</sup>, 3<sup>rd</sup>, 4<sup>th</sup> gen and Air models)\*
- pillowcase fabric graphic



Charging stations and kiosks are available in your choice of four thermoform finishes



FORMULATE KIOSKS

Formulate® Kiosks couple lightweight aluminum tube frames with state-of-the-art printed stretch zipper pillowcase fabric graphics to create funky and functional multimedia kiosks.



**KIOSK 1**  
FMLT-KIOSK-01

- 29.53" w x 98.53" h x 31.78" d
- pillowcase fabric graphic
- supports medium monitor\*

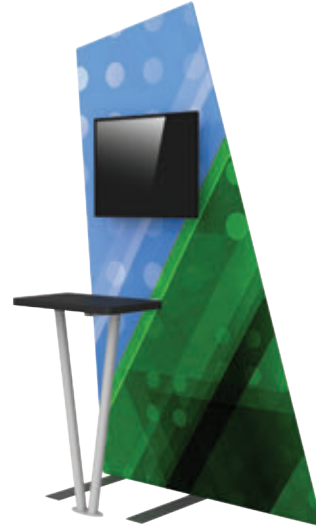

**KIOSK 2**  
FMLT-KIOSK-02

- 61.72" w x 98.16" h x 34.57" d
- pillowcase fabric graphic
- supports medium monitor\*



**KIOSK 3**  
FMLT-KIOSK-03

- 55.12" w x 98.61" h x 36.03" d
- pillowcase fabric graphic
- supports medium monitor\*



**KIOSK 4**  
FMLT-KIOSK-04

- 39.37" w x 92.52" h x 35.75" d
- pillowcase fabric graphic
- supports medium monitor\*

\*Monitors not included.



## FORMULATE ESSENTIAL HANGING STRUCTURES

Formulate® Essential fabric hanging structures are an economy range of standard, simple hanging structure shapes. The customary, economy aluminum tube frame features bungee cords and comes with a one year limited hardware warranty. Simply pull the pillowcase fabric graphic over the frame and zip. Essential hanging structure graphics do not come with a liner.

### RING

8' diam. x 2'h/3'h/4'h  
 10' diam. x 2'h/3'h/4'h  
 12' diam. x 2'h/3'h/4'h

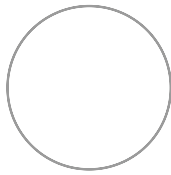

double sided graphic



bottom graphic

### SQUARE

8'w x 2'h/3'h/4'h  
 10'w x 2'h/3'h/4'h  
 12'w x 2'h/3'h/4'h

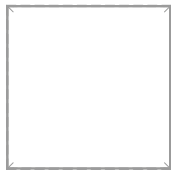

double sided graphic



bottom graphic

### TRIANGLE

8'w x 2'h/3'h/4'h  
 10'w x 2'h/3'h/4'h  
 12'w x 2'h/3'h/4'h

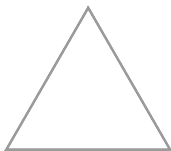

double sided graphic



bottom graphic



Formulate Essential hanging structures come with a one year limited hardware warranty.

## FORMULATE MASTER HANGING STRUCTURES

Formulate® tension fabric hanging structures are made in North America and are of the utmost quality and durability. Formulate combines state-of-the-art zipper pillowcase dye-sublimated stretch fabric coverings with advanced, lightweight aluminum structures to provide unique design, functionality, and style. The excellence of the Formulate line of hanging structures is simply unmatched!

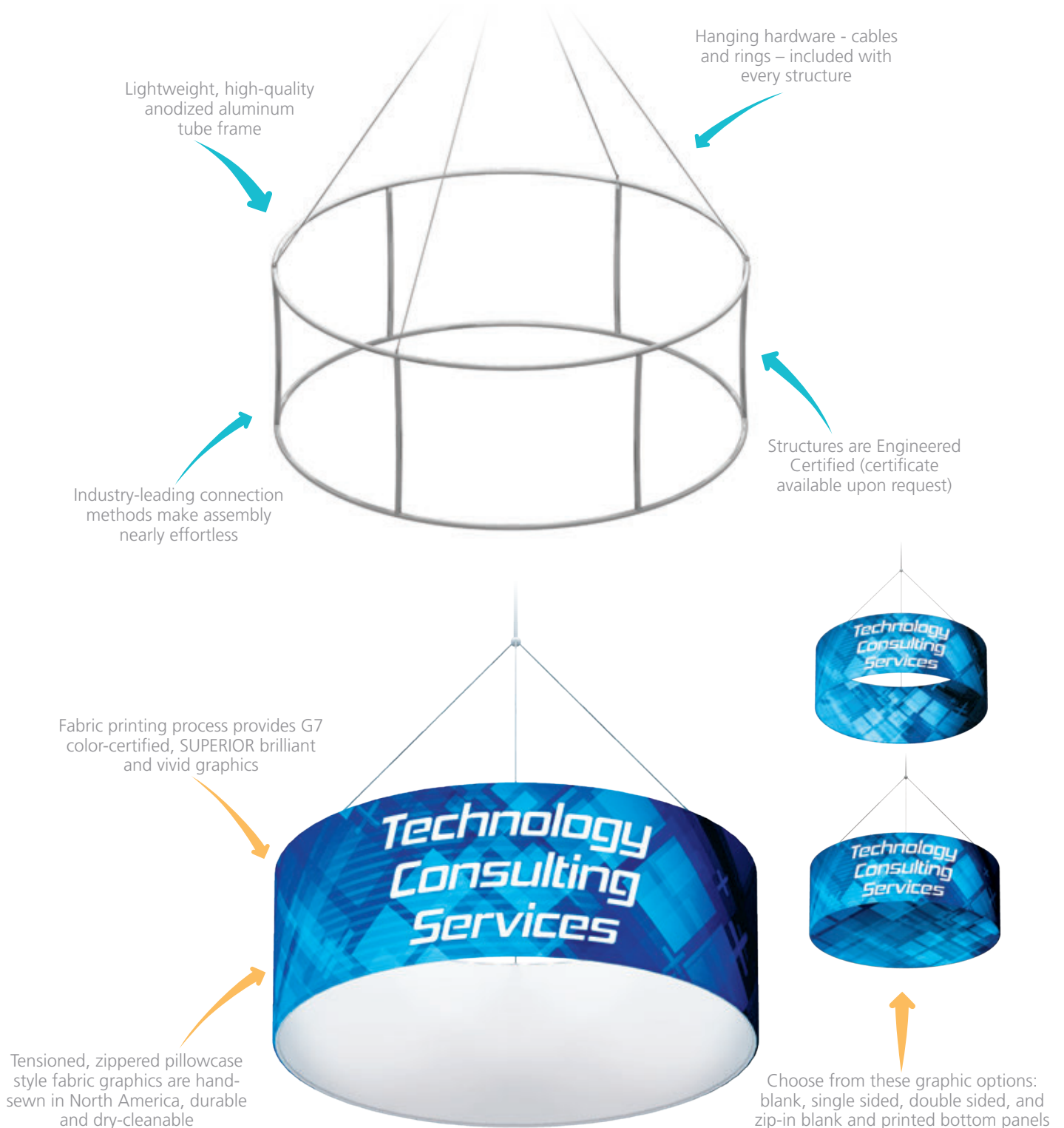

Formulate Master hanging structures are made in North America and have a limited lifetime hardware warranty.

**RING**

8' diam. x 2'h/3'h/4'h/5'h/6'h  
 10' diam. x 2'h/3'h/4'h/5'h/6'h  
 12' diam. x 2'h/3'h/4'h/5'h/6'h  
 14' diam. x 2'h/3'h/4'h/5'h/6'h  
 16' diam. x 2'h/3'h/4'h/5'h/6'h  
 18' diam. x 2'h/3'h/4'h/5'h/6'h  
 20' diam. x 2'h/3'h/4'h/5'h/6'h

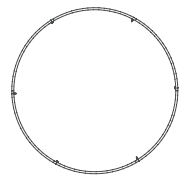

double sided graphic



bottom graphic

**TAPERED RING**

8' diam. x 2'h/3'h/4'h/5'h/6'h  
 10' diam. x 2'h/3'h/4'h/5'h/6'h  
 12' diam. x 2'h/3'h/4'h/5'h/6'h  
 14' diam. x 2'h/3'h/4'h/5'h/6'h  
 16' diam. x 2'h/3'h/4'h/5'h/6'h  
 18' diam. x 2'h/3'h/4'h/5'h/6'h  
 20' diam. x 2'h/3'h/4'h/5'h/6'h

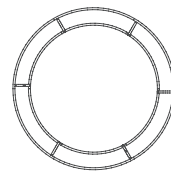

double sided graphic

**SQUARE**

8'w x 2'h/3'h/4'h/5'h/6'h  
 10'w x 2'h/3'h/4'h/5'h/6'h  
 12'w x 2'h/3'h/4'h/5'h/6'h  
 14'w x 2'h/3'h/4'h/5'h/6'h  
 16'w x 2'h/3'h/4'h/5'h/6'h  
 18'w x 2'h/3'h/4'h/5'h/6'h  
 20'w x 2'h/3'h/4'h/5'h/6'h

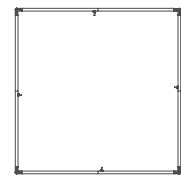

double sided graphic



bottom graphic

**TAPERED SQUARE**

8'w x 2'h/3'h/4'h/5'h/6'h  
 10'w x 2'h/3'h/4'h/5'h/6'h  
 12'w x 2'h/3'h/4'h/5'h/6'h  
 14'w x 2'h/3'h/4'h/5'h/6'h  
 16'w x 2'h/3'h/4'h/5'h/6'h  
 18'w x 2'h/3'h/4'h/5'h/6'h  
 20'w x 2'h/3'h/4'h/5'h/6'h

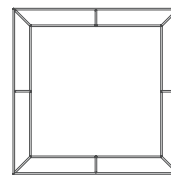

double sided graphic



certain shapes and sizes also available for rent



Formulate Master hanging structures are made in North America and have a limited lifetime hardware warranty.

### CONCAVE SQUARE

- 8'w x 2'h/3'h/4'h/5'h/6'h
- 10'w x 2'h/3'h/4'h/5'h/6'h
- 12'w x 2'h/3'h/4'h/5'h/6'h
- 14'w x 2'h/3'h/4'h/5'h/6'h
- 16'w x 2'h/3'h/4'h/5'h/6'h
- 18'w x 2'h/3'h/4'h/5'h/6'h
- 20'w x 2'h/3'h/4'h/5'h/6'h



double sided graphic

### TRIANGLE

- 8'w x 2'h/3'h/4'h/5'h/6'h
- 10'w x 2'h/3'h/4'h/5'h/6'h
- 12'w x 2'h/3'h/4'h/5'h/6'h
- 14'w x 2'h/3'h/4'h/5'h/6'h
- 16'w x 2'h/3'h/4'h/5'h/6'h
- 18'w x 2'h/3'h/4'h/5'h/6'h
- 20'w x 2'h/3'h/4'h/5'h/6'h

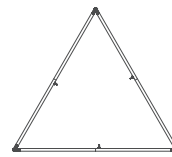

double sided graphic



bottom graphic

### TAPERED TRIANGLE

- 8'w x 2'h/3'h/4'h/5'h/6'h
- 10'w x 2'h/3'h/4'h/5'h/6'h
- 12'w x 2'h/3'h/4'h/5'h/6'h
- 14'w x 2'h/3'h/4'h/5'h/6'h
- 16'w x 2'h/3'h/4'h/5'h/6'h
- 18'w x 2'h/3'h/4'h/5'h/6'h
- 20'w x 2'h/3'h/4'h/5'h/6'h

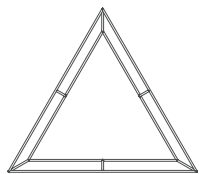

double sided graphic

### CONVEX TRIANGLE (SHIELD)

- 8'w x 2'h/3'h/4'h/5'h/6'h
- 10'w x 2'h/3'h/4'h/5'h/6'h
- 12'w x 2'h/3'h/4'h/5'h/6'h
- 14'w x 2'h/3'h/4'h/5'h/6'h
- 16'w x 2'h/3'h/4'h/5'h/6'h
- 18'w x 2'h/3'h/4'h/5'h/6'h
- 20'w x 2'h/3'h/4'h/5'h/6'h

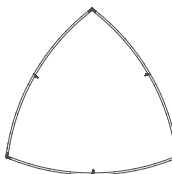

double sided graphic



OCE - Formulate Expandable Case

Structures collapse to a fraction of their size and come in standard carry bags and heavy-duty shipping and storage box(es).

Expandable, rugged molded shipping and transportation cases available as an upgrade.



certain shapes and sizes also available for rent



Formulate Master hanging structures are made in North America and have a limited lifetime hardware warranty.

**PINWHEEL**

8'w x 2'h/3'h/4'h/5'h/6'h  
 10'w x 2'h/3'h/4'h/5'h/6'h  
 12'w x 2'h/3'h/4'h/5'h/6'h  
 14'w x 2'h/3'h/4'h/5'h/6'h  
 16'w x 2'h/3'h/4'h/5'h/6'h  
 18'w x 2'h/3'h/4'h/5'h/6'h  
 20'w x 2'h/3'h/4'h/5'h/6'h



double sided graphic

**RECTANGLE**

8'w x 2'h/3'h/4'h/5'h/6'h  
 10'w x 2'h/3'h/4'h/5'h/6'h  
 12'w x 2'h/3'h/4'h/5'h/6'h  
 14'w x 2'h/3'h/4'h/5'h/6'h  
 16'w x 2'h/3'h/4'h/5'h/6'h  
 18'w x 2'h/3'h/4'h/5'h/6'h  
 20'w x 2'h/3'h/4'h/5'h/6'h

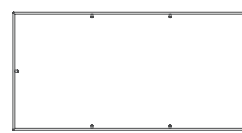

double sided graphic

**FOOTBALL**

8'w x 2'h/3'h/4'h/5'h/6'h  
 10'w x 2'h/3'h/4'h/5'h/6'h  
 12'w x 2'h/3'h/4'h/5'h/6'h  
 14'w x 2'h/3'h/4'h/5'h/6'h  
 16'w x 2'h/3'h/4'h/5'h/6'h  
 18'w x 2'h/3'h/4'h/5'h/6'h  
 20'w x 2'h/3'h/4'h/5'h/6'h

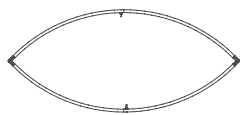

double sided graphic

**FOUR-SIDED PYRAMID**

10'w x 5'h  
 12'w x 6'h  
 16'w x 8'h  
 20'w x 10'h

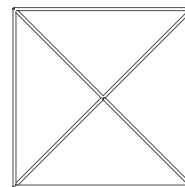

certain shapes and sizes also available for rent



Formulate Master hanging structures are made in North America and have a limited lifetime hardware warranty.

**CURVE**

- 8'w x 2'h/3'h/4'h/5'h/6'h
- 10'w x 2'h/3'h/4'h/5'h/6'h
- 12'w x 2'h/3'h/4'h/5'h/6'h
- 14'w x 2'h/3'h/4'h/5'h/6'h
- 16'w x 2'h/3'h/4'h/5'h/6'h
- 18'w x 2'h/3'h/4'h/5'h/6'h
- 20'w x 2'h/3'h/4'h/5'h/6'h



**PANEL**

- 8'w x 2'h/3'h/4'h/5'h/6'h
- 10'w x 2'h/3'h/4'h/5'h/6'h
- 12'w x 2'h/3'h/4'h/5'h/6'h
- 14'w x 2'h/3'h/4'h/5'h/6'h
- 16'w x 2'h/3'h/4'h/5'h/6'h
- 18'w x 2'h/3'h/4'h/5'h/6'h
- 20'w x 2'h/3'h/4'h/5'h/6'h



**DISC**

- 8' diameter
- 10' diameter
- 12' diameter
- 14' diameter
- 16' diameter
- 18' diameter
- 20' diameter



**S-CURVE**

- 8'w x 2'h/3'h/4'h/5'h/6'h
- 10'w x 2'h/3'h/4'h/5'h/6'h
- 12'w x 2'h/3'h/4'h/5'h/6'h
- 14'w x 2'h/3'h/4'h/5'h/6'h
- 16'w x 2'h/3'h/4'h/5'h/6'h
- 18'w x 2'h/3'h/4'h/5'h/6'h
- 20'w x 2'h/3'h/4'h/5'h/6'h

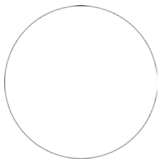

**WIDEST** RANGE OF OPTIONS!  
BEST IN **QUALITY.**

### CUBE

- 3'w x 3'h
- 4'w x 4'h
- 6'w x 6'h
- 8'w x 8'h
- 10'w x 10'h

\*illuminated cube also available

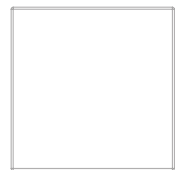

illuminated cube

### ROUNDED SQUARE

- 8'w x 2'h/3'h/4'h/5'h/6'h
- 10'w x 2'h/3'h/4'h/5'h/6'h
- 12'w x 2'h/3'h/4'h/5'h/6'h
- 14'w x 2'h/3'h/4'h/5'h/6'h
- 16'w x 2'h/3'h/4'h/5'h/6'h
- 18'w x 2'h/3'h/4'h/5'h/6'h
- 20'w x 2'h/3'h/4'h/5'h/6'h

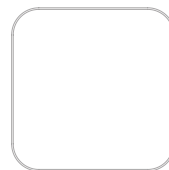

double sided graphic

### FOUR-SIDED PINWHEEL

- 8'w x 2'h/3'h/4'h/5'h/6'h
- 10'w x 2'h/3'h/4'h/5'h/6'h
- 12'w x 2'h/3'h/4'h/5'h/6'h
- 14'w x 2'h/3'h/4'h/5'h/6'h
- 16'w x 2'h/3'h/4'h/5'h/6'h
- 18'w x 2'h/3'h/4'h/5'h/6'h
- 20'w x 2'h/3'h/4'h/5'h/6'h

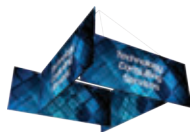
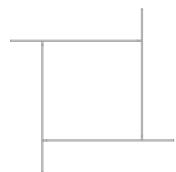

double sided graphic

### HEXAGON

- 8'w x 2'h/3'h/4'h/5'h/6'h
- 10'w x 2'h/3'h/4'h/5'h/6'h
- 12'w x 2'h/3'h/4'h/5'h/6'h
- 14'w x 2'h/3'h/4'h/5'h/6'h
- 16'w x 2'h/3'h/4'h/5'h/6'h

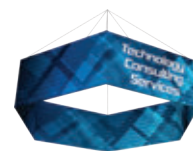
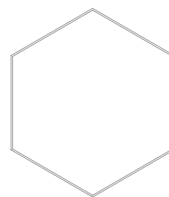

double sided graphic



Formulate Master hanging structures are made in North America and have a limited lifetime hardware warranty.



**EYE**

- 8'w x 2'h/3'h/4'h/5'h/6'h
- 10'w x 2'h/3'h/4'h/5'h/6'h
- 12'w x 2'h/3'h/4'h/5'h/6'h
- 14'w x 2'h/3'h/4'h/5'h/6'h
- 16'w x 2'h/3'h/4'h/5'h/6'h

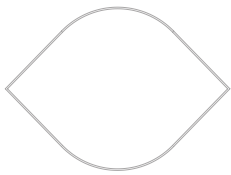

double sided graphic

**ILLUMINATED 3D OVAL**

- 10'w x 4'h
- 14'w x 6'h
- 18'w x 8'h



double sided graphic

**ILLUMINATED CAPSULE**

- 10'w x 4'h
- 14'w x 6'h
- 18'w x 8'h



- 10'w x 3'h
- 14'w x 4'h
- 18'w x 5'h

\*tiered bullet also available



double sided graphic

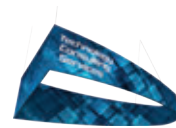

double sided graphic



Formulate Master hanging structures are made in North America and have a limited lifetime hardware warranty.

### TIERED SQUARE

10'w x 5'h  
12'w x 5'h  
14'w x 5'h  
16'w x 5'h

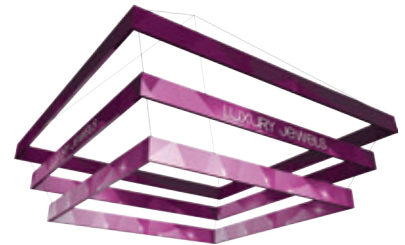
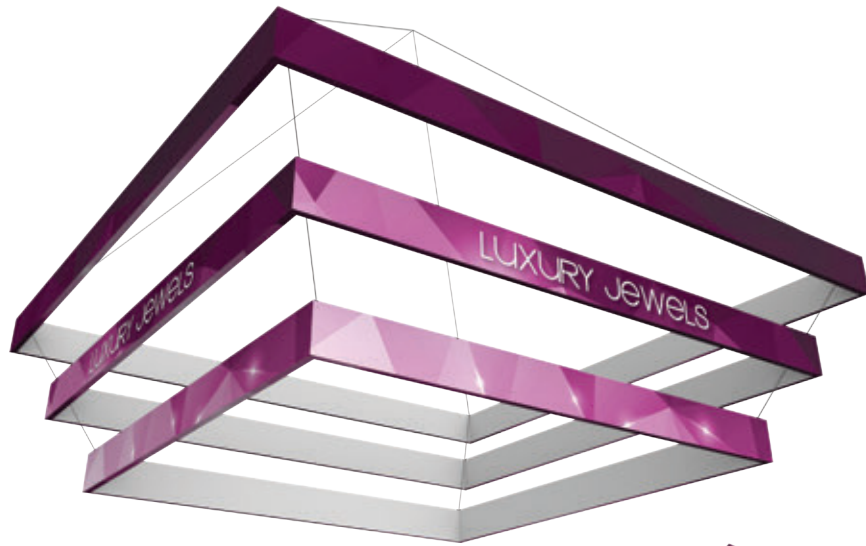
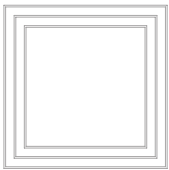

double sided graphic

### SQUARE MOBILE

15'w x 13'h

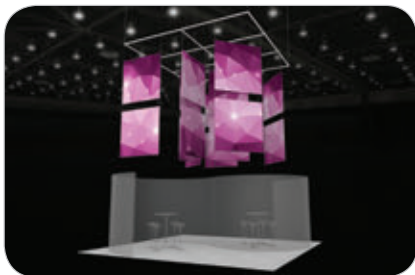
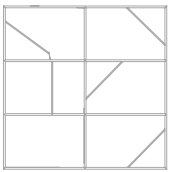

Formulate Designer Series hanging structures are made in North America and have a limited lifetime hardware warranty.

**TIERED RING**

10'diam. x 5'h  
 12'diam. x 5'h  
 14'diam. x 5'h  
 16'diam. x 5'h

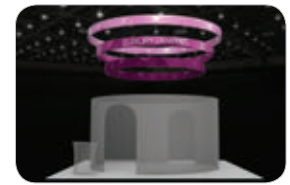
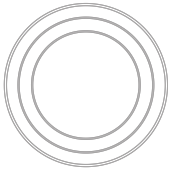

double sided graphic

**TIERED RING FLAT**

10'diam. x 3'h  
 12'diam. x 4'h  
 14'diam. x 5'h  
 16'diam. x 6'h

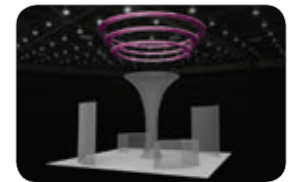
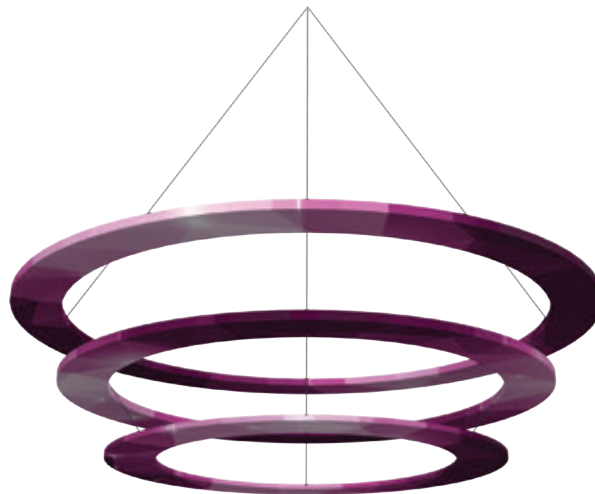
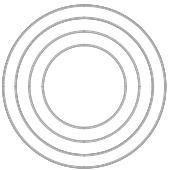

**TIERED BULLET**

10'w x 5'h  
 14'w x 7'h  
 18'w x 8.5'h

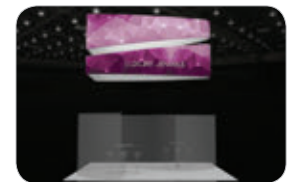

double sided graphic



Formulate Designer Series hanging structures are made in North America and have a limited lifetime hardware warranty.

# FORMULATE® | FUNNELS

## FORMULATE FUNNELS

When you are looking for a way to draw attention and captivate your audience at a tradeshow, special event, or in a permanent environment, these Formulate® tension fabric architectural structures are designed to impress.

Versatile Formulate Funnels transform any environment through form, fabric and lighting. Formulate Funnels have an hourglass shape, come in 20', 16' and 12' heights and have 8' diameters at the top and 3 ½' diameters at the bottom. Funnels feature a heavy-duty, wooden base and silver brushed coated truss interior to create a dynamic, towering structure that commands attention. Fabric graphics feature a zipper at the top and a silicone edge at the bottom for easy assembly. Accent LED light not included, but can be incorporated to add a glow within the funnel structures. Custom sizes also available.



16' FUNNEL  
FUN-04\*

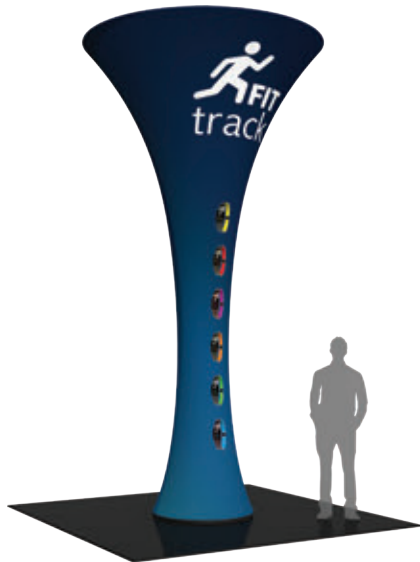

20' FUNNEL  
FUN-01



 16' FUNNEL  
FUN-02



12' FUNNEL  
FUN-03

\*Tablets not included.



Formulate structures are made in North America and a limited lifetime hardware warranty.

FORMULATE TOWERS

Mix and match the Formulate® line of towers to add architecture and drama to any event or interior space. Cylinder-shaped, Rectangular-shaped and Shield-shaped towers come in 12', 10' and 8' heights and 3' square/diameters at the tops and bottoms. They combine the latest developments in fabric printed technology with aluminum tube frames to add dimension, décor and sculpture to any event, stage set, tradeshow booth or interior space. Formulate towers accommodate internal LED lighting. Accent LED light not included, but can be incorporated to add a glow within the structures. Custom sizes also available.



12' FOUR SIDED TOWER  
COL-01



**R** 10' FOUR SIDED TOWER  
COL-02



8' FOUR SIDED TOWER  
COL-03



12' CYLINDER TOWER  
CYL-01



**R** 10' CYLINDER TOWER  
CYL-02



8' CYLINDER TOWER  
CYL-03



Formulate structures are made in North America and a limited lifetime hardware warranty.

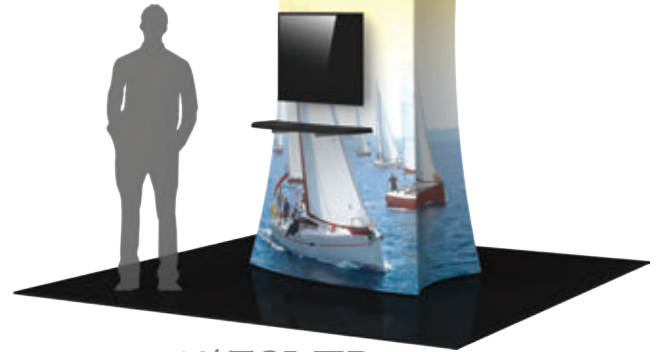

**10' TOWER**  
TOWER-02\*

**FORMULATE TOWERS**

When you are looking for a way to draw attention and captivate your audience at a tradeshow, special event, or in a permanent environment, these Formulate® tension fabric architectural structures are designed to impress.

Mix and match the Formulate line of towers to add architecture and drama to any event or interior space. Cylinder, Rectangular and Shield-shaped towers come in 12', 10' and 8' heights and 3' square/diameters at the tops and bottoms.



overhead view of shield towers



**12' SHIELD TOWER**  
SHD-TOWER-03

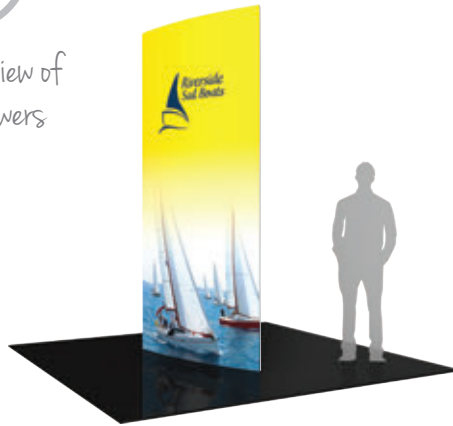

**10' SHIELD TOWER**  
SHD-TOWER-02



**8' SHIELD TOWER**  
SHD-TOWER-01

**INFLATABLE COLUMNS**

This free-standing inflatable column is great for indoor and outdoor use and can be customized with your own graphics. The hollow plastic base can be filled with water or sand for added stability. Ground stakes are sold separately.



**LARGE INFLATABLE COLUMN**  
INF-COL-L



**MEDIUM INFLATABLE COLUMN**  
INF-COL-M



**SMALL INFLATABLE COLUMN**  
INF-COL-S

\*Monitor not included.



# BROWSE OUR FULL LINE OF PORTABLE EXHIBITS & DISPLAYS IN THE **PORTABLE CATALOG**

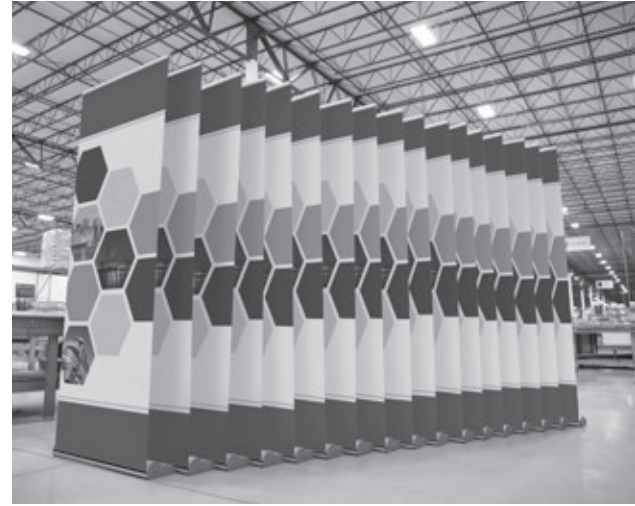

**OUTDOOR DISPLAYS**  
TENTS, FLAGS, SIGNS



**BANNER STANDS**  
WIDEST RANGE OF OPTIONS



**COLLAPSIBLE DISPLAYS**  
FAST, FABRIC DISPLAY SYSTEMS



## FORMULATE ARCHES

Formulate® Arches add architecture and design to any event or interior space! Easily create and define a stunning entryway, focal point or stage set at your next tradeshow or event with Formulate Arches.

Formulate Arches combine pillowcase style stretch fabric graphics with curved aluminum tube frames; these super structures are made in North America and collapse to a fraction of their size. Custom sizes also available.



overhead perspective

### ARCH 01 12' ARCH-01\*

The Formulate Arch 01 is 8' tall, spans 11 ½' wide and is nearly 8' deep at the bases. Two monitor mounts\* are included, externally facing, adding a bonus opportunity to display messaging and branding. Shown in a 12' space.

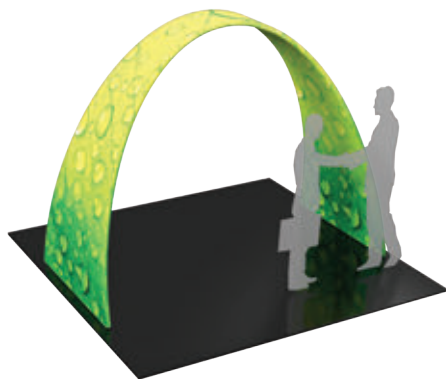

### ARCH 02 10' ARCH-02

The Formulate Arch 02 is 7 ⅔' tall, spans 9 ½' wide and is nearly 5' deep at the bases. Shown in a 10' space.

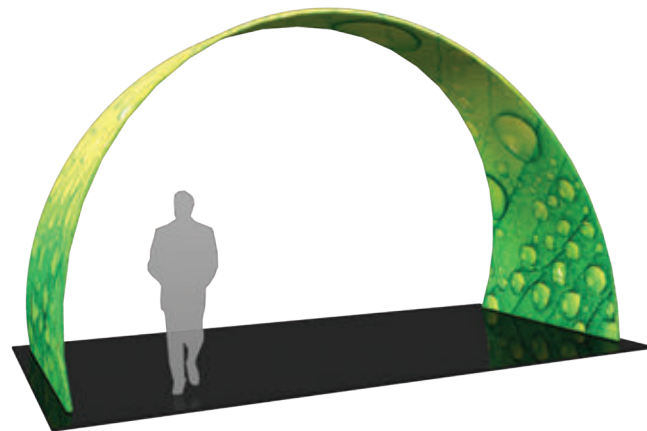

### ARCH 03 20' ARCH-03

The Formulate Arch 03 is 11 ½' tall, spans 19 ½' wide and is 8' deep at the bases. The Arch fits perfectly in a 20' x 20' island space. Shown in a 20' space.

\*Monitor not included.

Formulate structures are made in North America and a limited lifetime hardware warranty.





FORMULATE ARCHES

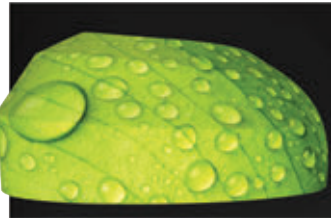
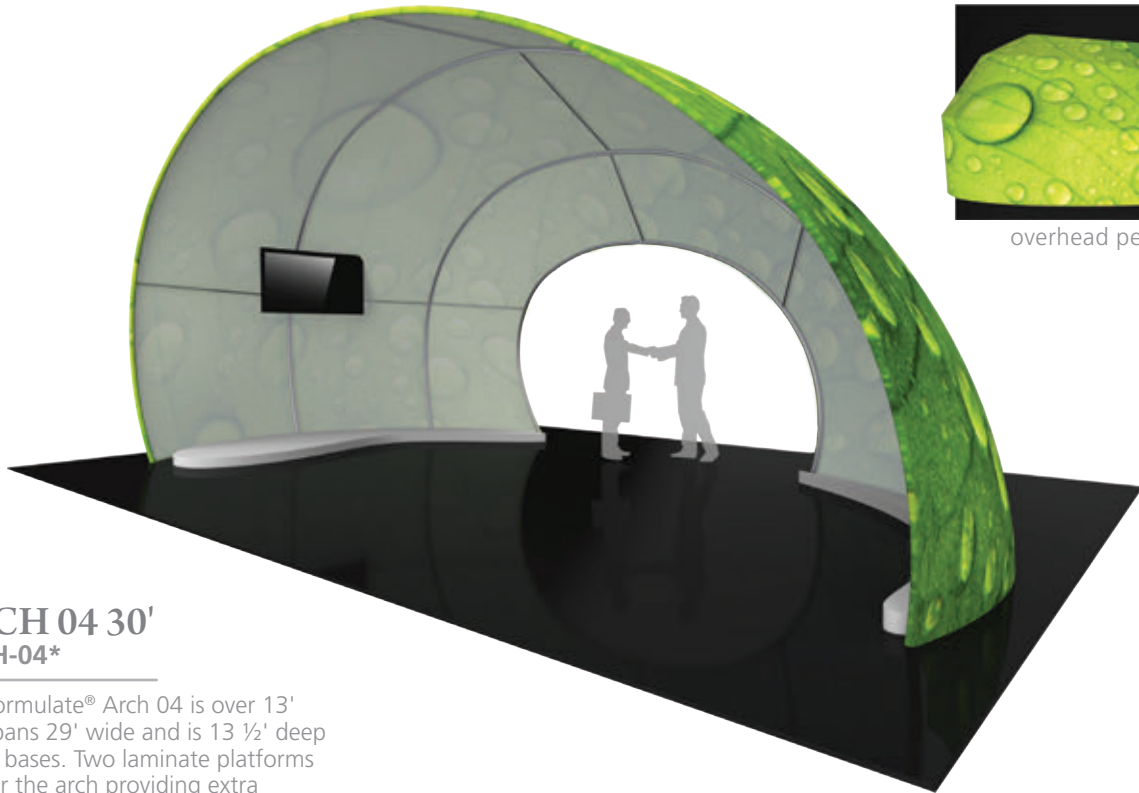

overhead perspective

**ARCH 04 30'**  
**ARCH-04\***

The Formulate® Arch 04 is over 13' tall, spans 29' wide and is 13 ½' deep at the bases. Two laminate platforms anchor the arch providing extra stability. Shown in a 30' space.

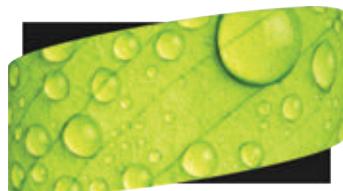
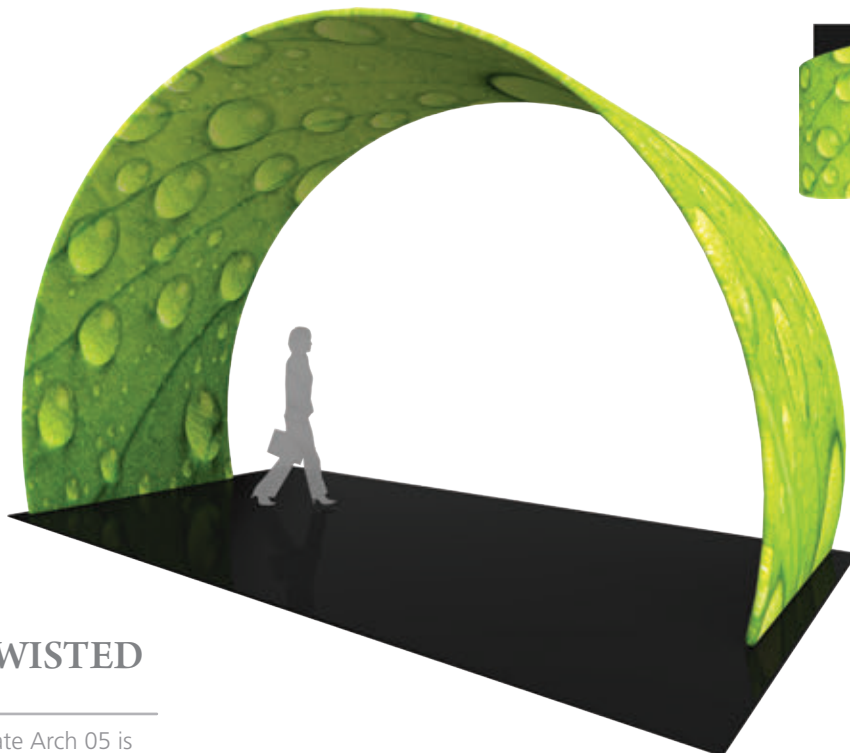

overhead perspective

**ARCH 05 TWISTED**  
**ARCH-05**

The Twisted Formulate Arch 05 is 12' tall, spans 19 ½' wide and is 10' deep at the bases. The twisted shape provides a unique style element. Shown in a 20' space.

\*Monitor not included.

## FORMULATE CONFERENCE WALLS

Whether you are looking to create a semi-private meeting area within a tradeshow exhibit, special event, or in an interior environment, Formulate® tension fabric conference walls are lightweight, stylish solutions to your meeting space needs.

Ergonomically designed, Formulate C-shaped, Chip-shaped and Serpentine-shaped walls combine the latest developments in fabric printed technology with gently curved 50mm aluminum frames to create private, cozy and stylish conference areas within any space.

### C-SHAPED WALL C-WALL

The Formulate C-Wall stands 7' tall at its highest point and is 7' 4" diameter. Perfect for a small table and chairs or benches for seating, this mini-conference area combines function and flare to create a stylish, semi-private space.

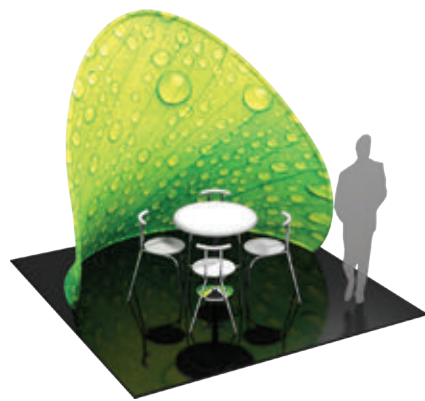
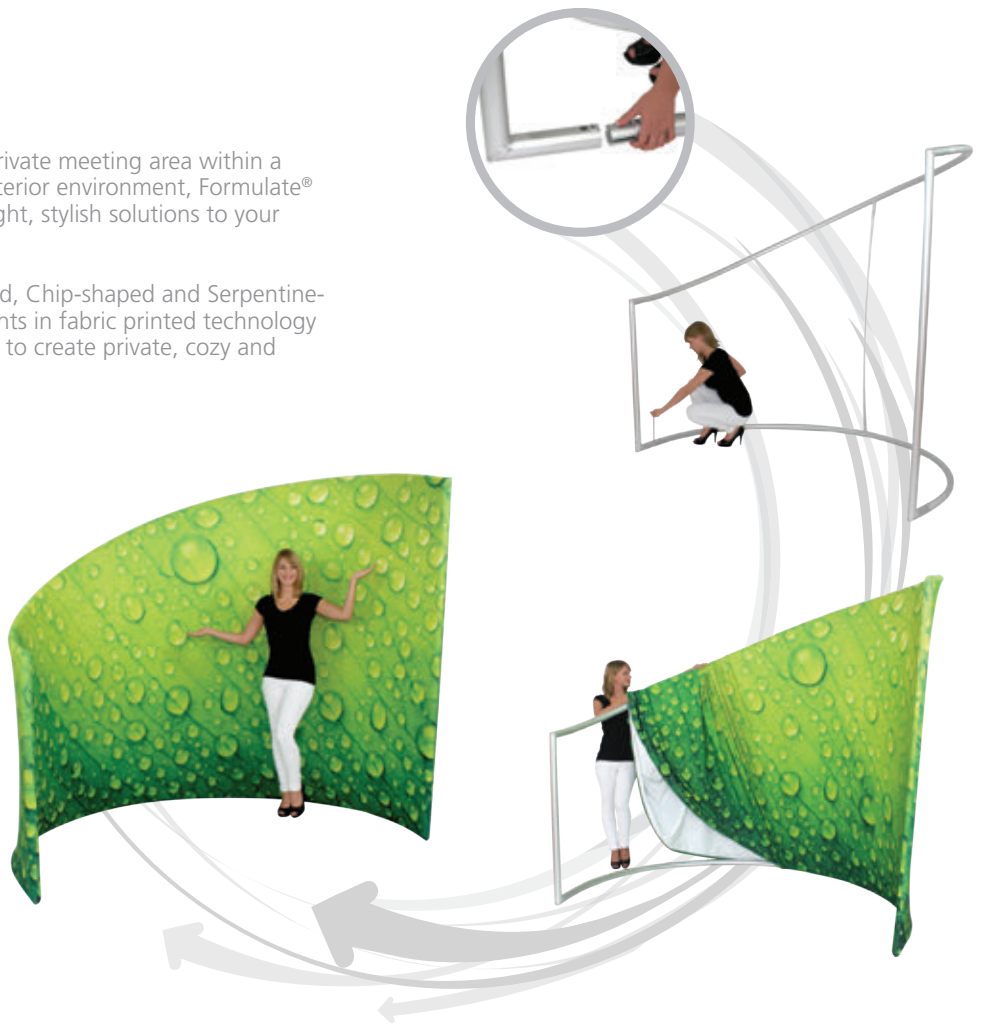

### CHIP-SHAPED WALL CHIP-WALL\*



The Formulate Chip-Shaped Wall is a potato chip shaped structure that stands 8' tall and is 9' 3" wide. It is an ideal structure to create a semi-private conference/meeting area or projection wall within a space.



### CHIP-SHAPED WALL CHIP-WALL-02\*

The Formulate Chip Wall 02 is a curved conference room divider that stands 6' 4" tall and is 9' 5" wide. It is an ideal structure to create a semi-private conference/meeting area or projection wall within a space.

\*Furniture not included.

Formulate structures are made in North America and a limited lifetime hardware warranty.



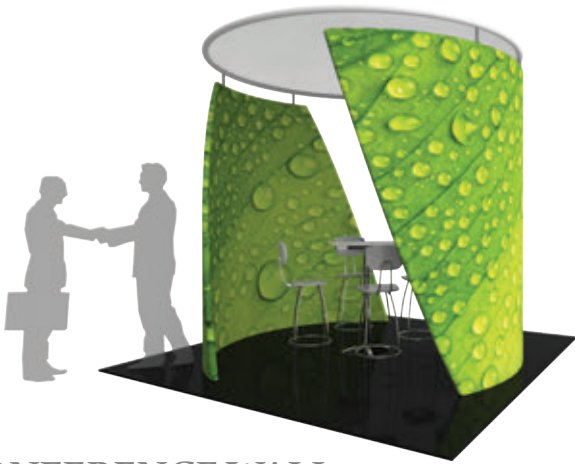

**CONFERENCE WALL**  
**C-WALL-02\***

The Formulate® standalone conference room features two fabric walls and a sheer fabric canopy to create a stylish semi-private conference space. The conference room is large enough to house a small table and four chairs. Conference Wall 02 is 8'6" tall and has a diameter of 9'. Furniture not included.

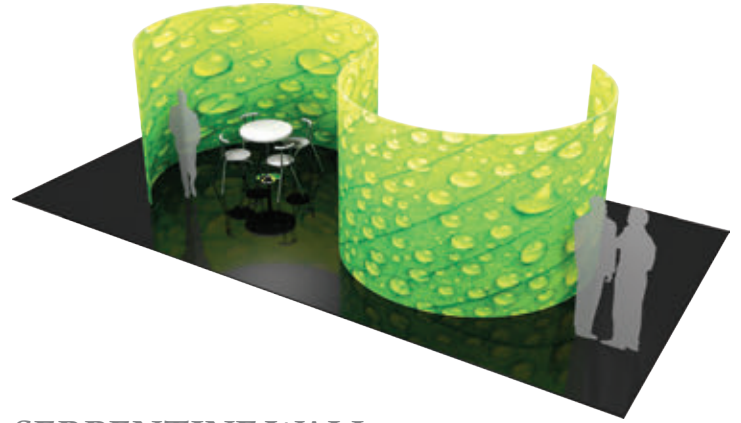

**SERPENTINE WALL**  
**S-WALL\***

The Formulate Serpentine shaped wall connects two C-shaped structures to create a multipurpose, Serpentine shaped display. The Serpentine Wall is ideally used as a wall that separates two mini-conference and meeting areas. The Formulate Serpentine Wall is 7' 7" tall and spans 22' 10" wide – perfect for use in a large island space. Furniture not included.

**FORMULATE VIDEO WALLS & ROOMS**

Heavy-duty 50mm aluminum frames are coupled with stretch, zipper pillowcase fabric graphics to create flowing, uniquely-shaped Formulate curved walls and architectural structures that are ideal for tradeshow, events, corporate environments and interior spaces. With a variety of options, you can mix and match with other Formulate fabric structures to create the ideal display, booth or environment. Custom sizes also available.

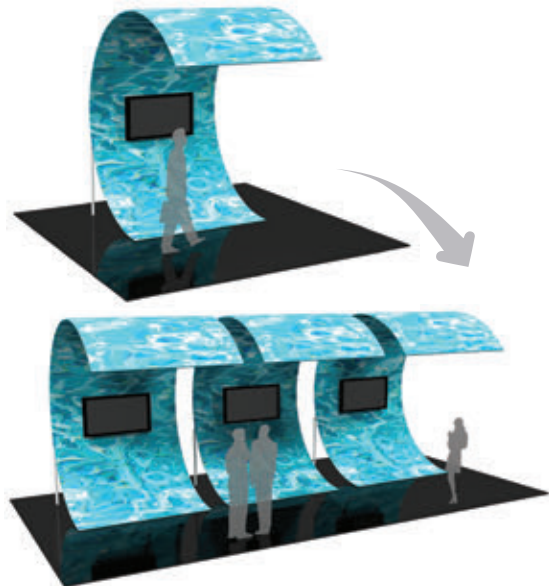

**SURF**  
**SURF-WALL\***

The Formulate Surf Wall is a C-shaped multimedia display that stands 11' 4" tall with a width of 7' 7". With an organic, curved shape sustained by supporting legs, and a monitor mount for a monitor/TV, the Surf makes a distinctive statement in any space.



**TREE HOUSE**  
**TREEHOUSE-RM**



The Formulate Tree House is a cylinder-shaped space perfect for meetings, graphical displays, projected presentations, a theater setting and much more. The Tree House is 15' in diameter, 8' tall and features two 7' tall doorways, encouraging traffic flow through the structure.

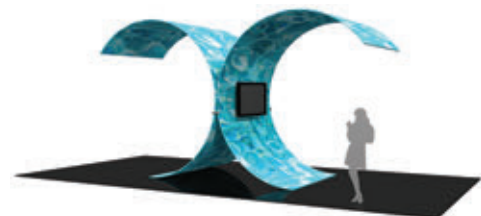

**TREE**  
**TREE\***

Two C-shaped structures are fused together to create a Tree shape with this sculptural, multimedia display. The Formulate Tree stands 11' 4" tall and spans to 20' 6" wide. The Formulate Tree includes two monitor mounts for use as a multimedia display.

\*Monitor and furniture not included.



Hybrid Pro Modular  
Kit 03  
HP-K-03



Hybrid Pro Modular  
Kit 03, p. 162



Hybrid Pro Modular  
Kit 11, p. 164



Vector Frame Light Box,  
p. 172

## MODULAR **EXHIBIT** SYSTEMS

Modular exhibit systems and displays provide exhibitors with sophisticated, custom-looking exhibits that stand the test of time, and can adapt and evolve from show to show. Using standardized components as building blocks, modular displays can often be reconfigured to fit multiple size spaces and customized to fit unique needs.

Modular displays are used in tradeshows and events, and are often used as permanent displays in museums and educational environments and in retail settings.

Many of our modular exhibit systems combine aluminum extrusion frames with push-fit fabric graphics. North American-made modular exhibit systems are created by expert welding and metal-working technicians. Graphics are printed with the latest state-of-the-art large format printers, and all graphics are produced and finished by hand by highly-skilled sewers in North America.

Our variety of modular display systems offer displays of many types and sizes, from banners and light boxes to table-top displays, through to 10' and 20' inline exhibit kits, as well as 20' by 20' island exhibit kits. Display accent pieces and accessories such as charging stations, counters, multi-media kiosks, lighting and more help add functionality and the final finishing touches.

## BOLD EXHIBITS, MADE **INGENIOUSLY** SIMPLE.



Magellan Orbital Express  
Truss, p. 203



Hybrid Pro Modular  
Kit 19, p. 167



HYBRID PRO KIT 01  
HP-K-01



## HYBRID PRO **MODULAR**

The sophisticated, striking appearance of Hybrid Pro™ Modular exhibits takes exhibiting to a new level.

The Hybrid Pro Modular series is a collection of modular and reconfigurable exhibit backwalls and counters that feature heavy-duty aluminum frames, push-fit fabric graphics and high-end features such as tables, monitor mounts, interior LED lighting and more. The intricacy of the details makes these exhibits impossible not to notice.

Versatile inline 10' x 20' Hybrid Pro Modular displays reconfigure to 10' x 10' versions, increasing the value and lifecycle of the exhibit, as well as the investment. Counters can be mixed and matched and are often used for non-tradeshow applications as well; the quality is like a custom-made furniture piece!

All Hybrid Pro Modular display frames are quality crafted and manufactured in North America. All push-fit and pillowcase fabric graphics are produced in North America, printed on state-of-the-art, G7 color certified printers and are finished by hand.

## **MAXIMIZE YOUR INVESTMENT AND IMPACT WITH A HYBRID PRO MODULAR DISPLAY!**



10' x 10' Displays



10' x 20' Exhibits



20' x 20' Island Kits

# HYBRID PRO™ MODULAR | 10' EXHIBIT KITS

## HYBRID PRO 10' MODULAR BACKWALLS

If you are a serious exhibitor looking to make a lasting impression with a sophisticated, feature-rich exhibit, the Hybrid Pro™ Modular line of exhibits, counters and accessories will help you make a big splash. The Hybrid Pro line of modular exhibits feature heavy-duty aluminum extrusion frames and easy-to-apply silicone edge push-fit fabric graphics.

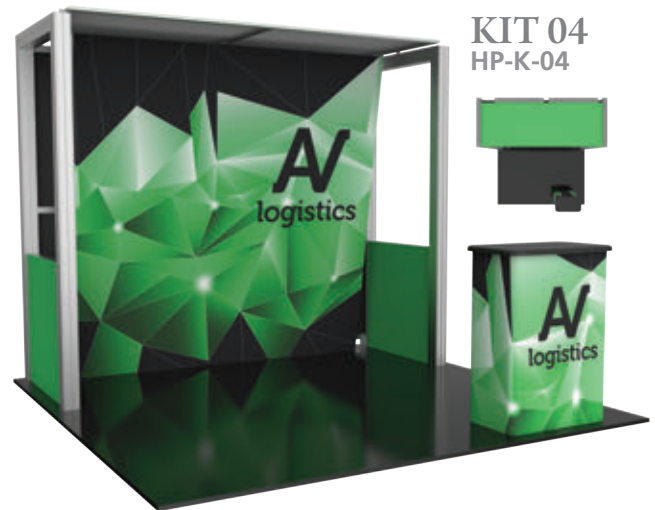
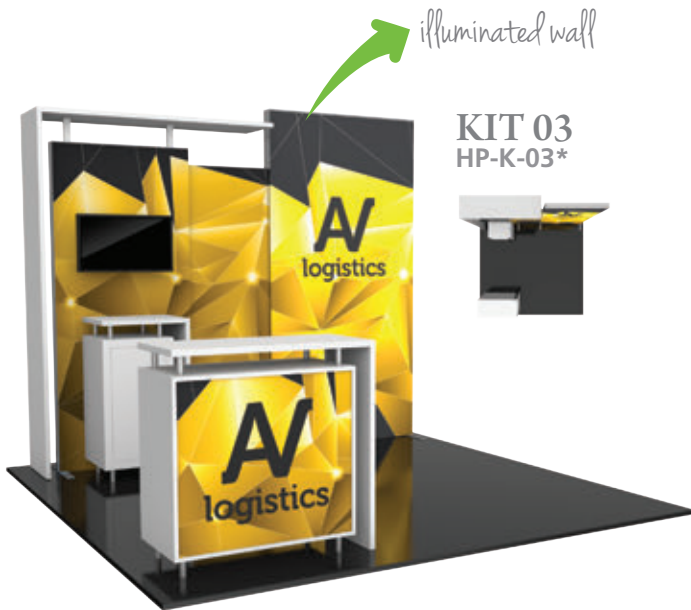
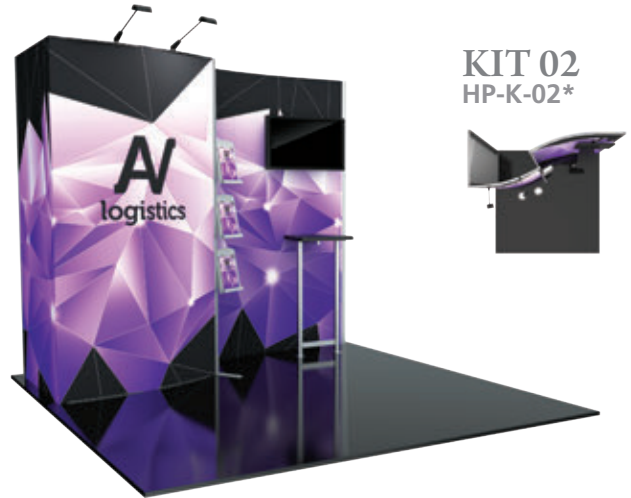
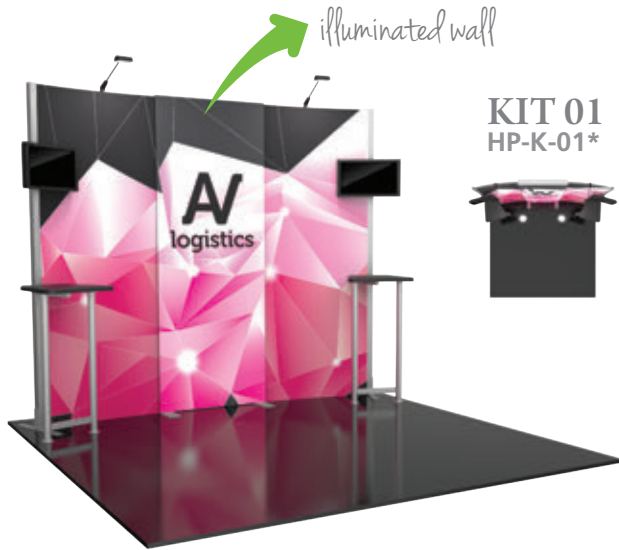

easy to apply push-fit fabric graphics





# 10' EXHIBIT KITS | HYBRID PRO™ MODULAR



All Hybrid Pro Modular kits are also available for rent

**KIT 05**  
HP-K-05

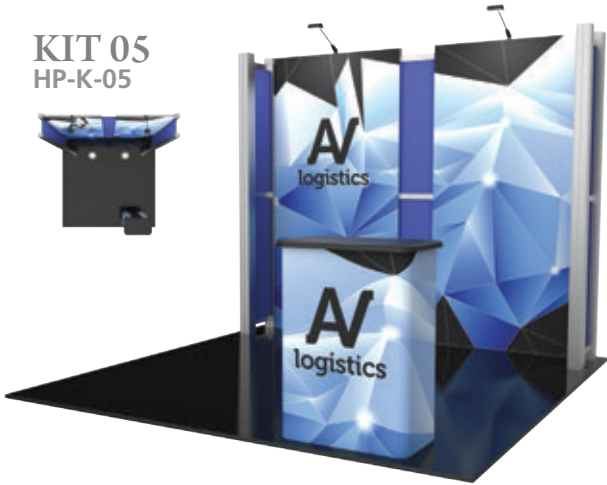

**KIT 06**  
HP-K-06\*

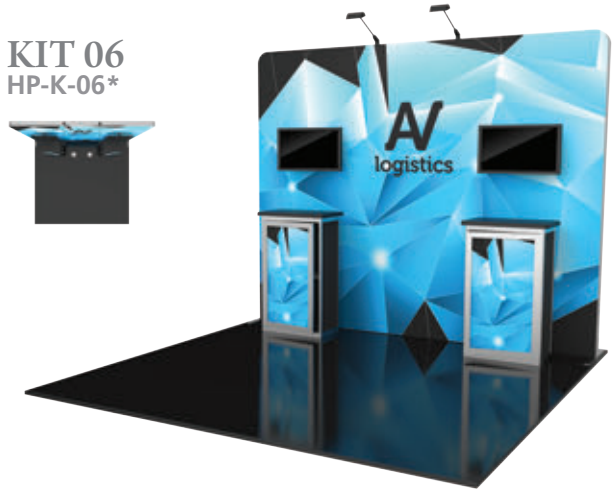

**KIT 07**  
HP-K-07\*



**KIT 08**  
HP-K-08\*



Counters featured on p.133

Hybrid Pro counter tops are available in your choice of four thermoform finishes



silver black mahogany natural

\*Monitors not included.

Counters featured in foreground sold separately; see pages 132-133 for options.

# HYBRID PRO™ MODULAR | 20' EXHIBIT KITS

## HYBRID PRO 20' MODULAR BACKWALLS

If you are a serious exhibitor looking to make a lasting impression with a sophisticated, feature-rich exhibit, the Hybrid Pro™ Modular line of exhibits, counters and accessories will help you make a big splash. The Hybrid Pro line of modular exhibits feature heavy-duty aluminum extrusion frames and easy-to-apply silicone edge push-fit fabric graphics.

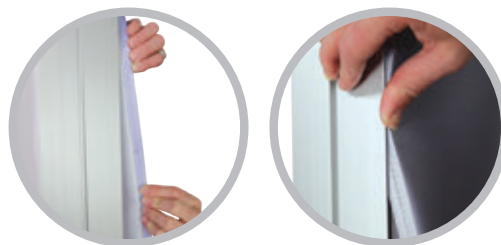
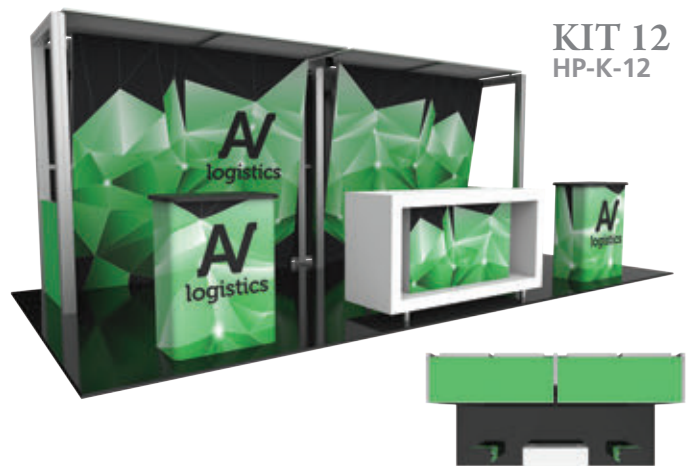
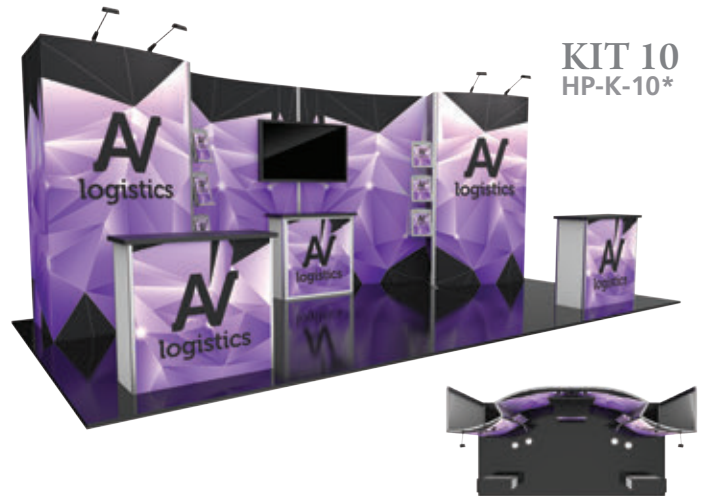
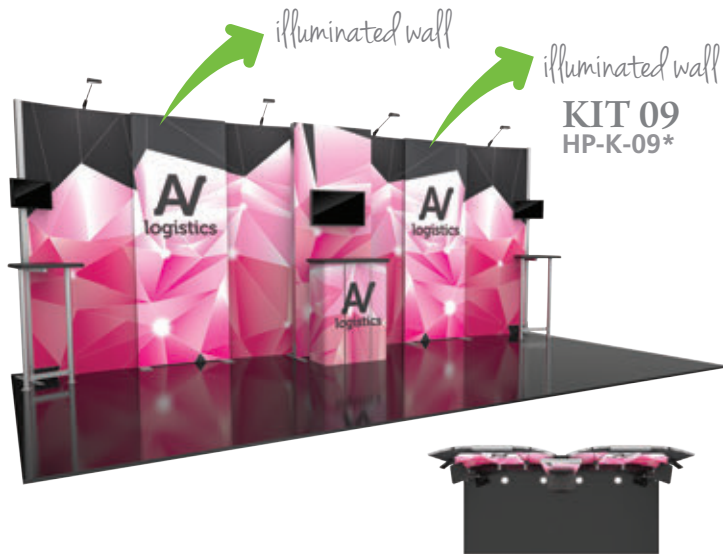

easy to apply push-fit fabric graphics



All Hybrid Pro Modular displays are made in North America and come with a limited lifetime hardware warranty.

# 20' EXHIBIT KITS | HYBRID PRO™ MODULAR



All Hybrid Pro Modular kits are also available for rent

**KIT 13**  
HP-K-13\*

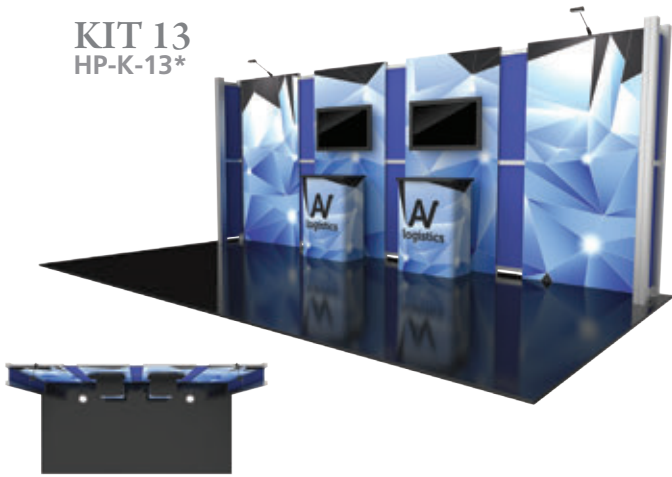

**KIT 14**  
HP-K-14\*

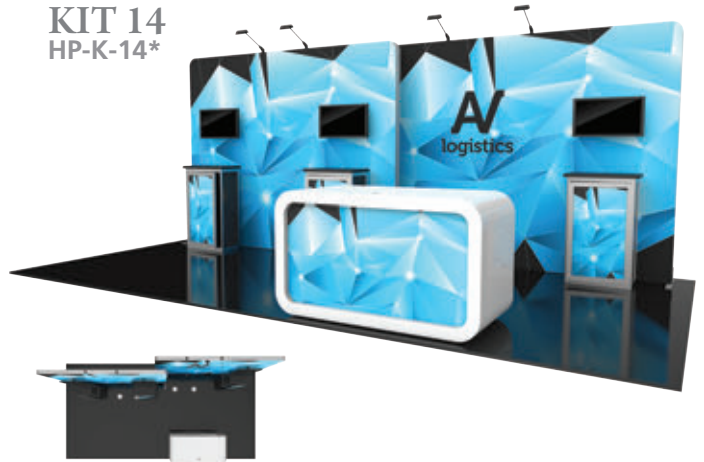

**KIT 15**  
HP-K-15\*



**KIT 16**  
HP-K-16\*

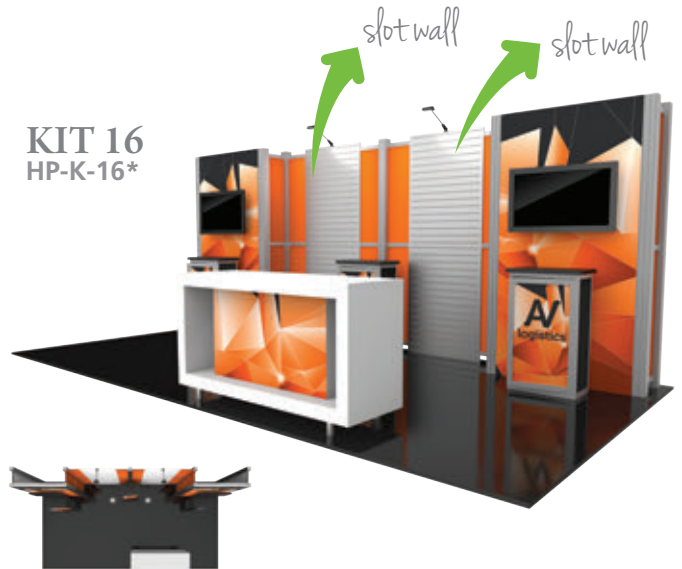

Counters featured on p.133

Hybrid Pro counter tops are available in your choice of four thermoform finishes



silver black mahogany natural

\*Monitors not included.

Counters featured in foreground sold separately; see pages 132-133 for options.

# HYBRID PRO™ MODULAR | 20' x 20' ISLAND EXHIBIT KITS

Hybrid Pro™ Modular island exhibit kits provide an unparalleled dynamic that elevates and accentuates a message and brand, but also maximizes the return on tradeshow investment. Hybrid Pro Modular is a collection of 20' x 20' exhibit kits and custom solutions. Heavy-duty aluminum is coupled with dynamic graphics to create sophisticated, commanding and unforgettable island spaces. All Hybrid Pro Modular exhibits and graphics are made in North America.

## HYBRID PRO MODULAR KIT 17 HP-K-17\*

- 15'9" tall 20' x 20' island display
- Heavy-duty aluminum extrusion frame coupled with seamless push-fit SEG fabric graphics
- Base structure features white laminate panels with accessible storage closet
- Kit includes frame, accessible lockable storage space, four pillowcase graphics, two fabric graphic panels, three shaped Sintra panels, three counters, six small monitor mounts\*, six 200 LED floodlights, two molded OCE storage cases and one woodcrate



Isometric View

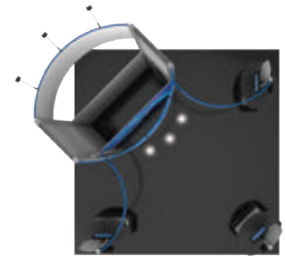

Overhead View

## HYBRID PRO MODULAR KIT 18 HP-K-18\*

- 11'10" tall square shaped island display
- Square-shaped, heavy-duty aluminum extrusion frame coupled with seamless push-fit SEG fabric graphics
- Kit includes frame, 16 fabric graphic panels, one white laminate counter, eight literature holders, 16 200 LED floodlights and one woodcrate
- Accessible storage and locking door
- Reception counter (HCP-11) and flooring not included



Isometric View

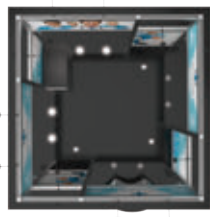

Overhead View



\*Monitor not included.

All Hybrid Pro Modular displays are made in North America and come with a limited lifetime hardware warranty.

# 20' x 20' ISLAND EXHIBIT KITS | HYBRID PRO™ MODULAR



All Hybrid Pro Modular Island Exhibit kits are also available for rent

## HYBRID PRO MODULAR KIT 19 HP-K-19\*

- 15'9" tall island display
- Heavy-duty aluminum extrusion frame coupled with seamless push-fit SEG fabric graphics
- Features two semi-private meeting alcoves with curved frosted plex infills
- Storage room features white laminate panels, locking door & monitor mount
- Kit includes frame, eight fabric graphic panels, two curved plex infills, laminate storage room, four tables, four small monitor mounts\*, one large monitor mount\*, 16 200 LED floodlights and one woodcrate
- Flooring and HPC-04 counter not included



Isometric View

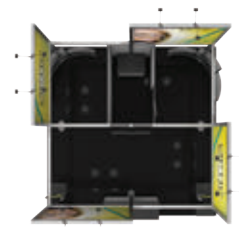

Overhead View

## HYBRID PRO MODULAR KIT 20 HP-K-20\*

- Stands approximately 14' tall and features a 12'd x 4'h circular ring structure, laminated wood structures and fabric graphic walls
- Single-sided dye-sublimated push-fit fabric graphics with Velcro on perimeter
- Four internally facing shelving areas feature three 24" x 24" shelves each
- Kit includes laminate walls, ten fabric graphic panels, one pillowcase fabric graphic, two large monitor mounts, two large monitor mounts\*, 12 shelves, one molded OCE case, two woodcrates and one NCRATE
- Flooring and center counter REC-42 not included



Isometric View



Overhead View



\*Monitor not included.

All Hybrid Pro Modular displays are made in North America and come with a limited lifetime hardware warranty.

# HYBRID PRO™ MODULAR | COUNTERS

## HYBRID PRO COUNTERS

All Hybrid Pro™ Modular counters feature accessible storage and locking doors. Printed fabric graphics or rigid infill panels allow for your messaging and branding. Choose the size and counter shape that will match your backwall and space best.



### HYBRID PRO COUNTER 01

**HPC-01**

- 39.38" w x 39.38" h x 17.75" d
- white laminate cabinet with fabric graphic on the front, opaque or backlit



### HYBRID PRO COUNTER 02

**HPC-02**

- 70.88" w x 39.38" h x 23.63" d
- white laminate cabinet with fabric graphic on the front, opaque or backlit



### HYBRID PRO COUNTER 03

**HPC-03**

- 39.38" w x 36.63" h x 15.75" d
- white laminate panel cabinet with UV graphic on the front and laminate top



### HYBRID PRO COUNTER 04

**HPC-04**

- 73.75" w x 36.5" h x 25.38" d
- white laminate panel cabinet with UV graphic on the front and laminate top



Counter 01



Counter 03



Counter 04



All Hybrid Pro Modular counters are also available for rent.

# COUNTERS | HYBRID PRO™ MODULAR

Select Hybrid Pro counter tops are available in your choice of four thermoform finishes



Select Hybrid Pro counter bodies are available in your choice of four laminate colors



## HYBRID PRO COUNTER 09

**REC-42**

- 46" w x 37.5" h x 23" d
- white laminate cabinet with UV graphic on the front, opaque or backlit



## HYBRID PRO COUNTER 10

**REC-52**

- 64" w x 37.5" h x 30" d
- white laminate cabinet with UV graphic on the front, opaque or backlit



## HYBRID PRO COUNTER 11

**RCK-06**

- 71.06" w x 36.61" h x 32.72" d
- white laminate panel cabinet with UV graphic on the front and laminate top



Counter 11



Counter 09



Counter 02



All Hybrid Pro Modular counters are also available for rent.



VECTOR FRAME KIT 15  
VF-K-15





## VECTOR FRAME **GEOMETRIC**

The innovative, contemporary and clean appearance of the Vector Frame™ line of geometric displays will captivate and **WOW** your audience.

The Vector Frame series is a collection of geometric shaped backwalls, banners, exhibit kits, counters and light boxes that feature durable, easy-to-assemble aluminum extrusion frames and push-fit fabric graphics. Vector Frame exhibit kits come with accent lighting, tables, counters, literature accessories, monitor mounts and interior LED edge lighting where indicated.

Vector Frame can be reconfigured and customized to create completely tailored exhibits and interior display solutions.

All Vector Frame display frames are quality crafted and manufactured in North America. All push-fit fabric graphics are produced in North America, printed on state-of-the-art, G7 color certified printers and are finished by hand.

You will certainly make a strong and lasting impression with Vector Frame exhibits, counters and light boxes at your tradeshow or event.

## MAKE AN IMPACT WITH A **CLEAN, CONTEMPORARY** FABRIC DISPLAY.



Banners



Light Boxes



Essential Kits



Master Kits

**VECTOR FRAME LIGHT BOXES**

Vector Frame™ fabric light boxes feature durable 4" aluminum extrusion frames, push-fit INTENSITY backlit fabric graphics and LED edge lighting. Single and double sided graphic options are available.



LED lights come adhered to the frame, making set-up as simple as:

1. assembling the frame
2. applying the push-fit graphics
3. plugging in the electrical cord!

04 Rectangle  
**VF-LB-R-04**



48.11" w x 94.74" h x 19.69" d  
comes in OCH case

**LIGHT BOXES**



01 Square  
**VF-LB-S-01**  
36.3" w x 35.68" h x 19.69" d  
comes in 1 OCE case



02 Square  
**VF-LB-S-02**  
48.11" w x 47.49" h x 19.69" d  
comes in 1 OCE case



03 Square  
**VF-LB-S-03**  
71.73" w x 71.12" h x 19.69" d  
comes in 1 OCH case



05 Square  
**VF-LB-S-05**  
95.35" w x 94.74" h x 19.69" d  
comes in 1 OCH case



01 Square  
**VF-LB-S-01**  
36.3" w x 35.68" h x 19.69" d  
comes in 1 OCE case



02 Square  
**VF-LB-S-02**  
48.11" w x 47.49" h x 19.69" d  
comes in 1 OCE case



03 Square  
**VF-LB-S-03**  
71.73" w x 71.12" h x 19.69" d  
comes in 1 OCH case



04 Square  
**VF-LB-S-04**  
95.35" w x 94.74" h x 19.69" d  
comes in 1 OCH case



All Vector Frame displays are made in North America and have a limited lifetime hardware warranty.

VECTOR FRAME BANNERS

Vector Frame™ banners combine aluminum extrusion frames with push-fit fabric graphics to create a versatile banner, backwall, hanging art or display. Vector Frame banners can be used to display messaging or art in a corporate environment or at a tradeshow and feature 2" aluminum extrusion frame and single or double sided graphics.



05 Rectangle  
**VF-R-05**  
118.98" w x 94.74" h x 19.69" d  
comes in 1 OCL case



*easy to apply  
push-fit fabric graphics*

*fits perfect in a 10' space!*

BANNERS



01 Rectangle  
**VF-R-01**  
36.3" w x 47.49" h x 19.69" d  
comes in 1 OCL case



02 Rectangle  
**VF-R-02**  
36.3" w x 71.12" h x 19.69" d  
comes in 1 OCS case



03 Rectangle  
**VF-R-03**  
48.11" w x 71.12" h x 19.69" d  
comes in 1 OCL case



04 Rectangle  
**VF-R-04**  
48.11" w x 94.74" h x 19.69" d  
comes in 1 OCL case



01 Square  
**VF-S-01**  
36.3" w x 35.68" h x 19.69" d  
comes in 1 OCS case



02 Square  
**VF-S-02**  
48.11" w x 47.49" h x 19.69" d  
comes in 1 OCL case



03 Square  
**VF-S-03**  
71.73" w x 71.12" h x 19.69" d  
comes in 1 OCS case



04 Square  
**VF-S-04**  
95.35" w x 94.74" h x 19.69" d  
comes in 1 OCL case



All Vector Frame displays are made in North America and have a limited lifetime hardware warranty.

**VECTOR FRAME CURVED BANNERS**

Vector Frame™ curved banners combine 2" aluminum extrusion frames with push-fit fabric graphics to create a versatile single and double sided banner, backwall or interior display. Use as a concave or convex shape.



01 Curved Rectangle  
**VF-CR-01**  
39.33" w x 94.74" h x 19.69" d  
comes in 1 OCL case



02 Curved Rectangle  
**VF-CR-02**  
56.75" w x 94.74" h x 19.49" d  
comes in 1 OCL case



03 Curved Rectangle  
**VF-CR-03**  
68" w x 94.74" h x 18.75" d  
comes in 1 OCL case

**VECTOR FRAME MONITOR KIOSKS**

Vector Frame™ Monitor Kiosks are a sleek, stylish way to display media at any tradeshow, event, in a retail or corporate space. The kiosks feature push-fit fabric graphics, easy-to-assemble 4" extrusion frames, your choice of single or double sided graphics and one or two monitor mounts (monitors not included). These kiosks complement the Vector Frame line of banners, backwalls, exhibit kits and counters.



01 Monitor Kiosk  
**VF-MK-01-SS**  
**VF-MK-01-DS**  
36.3" w x 94.74" h x 19.69" d  
comes in 1 OCH case  
supports 32-55" monitor\*;  
max weight = 80 lbs each

front with graphic & monitor mount\*



back with graphic



back with graphic & monitor mount\*



top view  
one monitor mount



02 Monitor Kiosk  
**VF-MK-02-SS**  
**VF-MK-02-DS**  
48.11" w x 94.74" h x 19.69" d  
comes in 1 OCH case  
supports 32-55" monitor\*;  
max weight = 80 lbs each

front with graphic & monitor mount\*



back with graphic



back with graphic & monitor mount\*



top view  
two monitor mounts

\*Monitors not included.

VECTOR FRAME **EDGE POSTER FRAMES**

Vector Frame™ Edge fabric poster displays combine durable, slim 3/4" lightweight aluminum extrusion frames and easy-to-apply push-fit fabric graphics. Custom frame sizes are available.



**Square Sizes:**

- VFE-S-01: 11.8" w x 11.8" h
- VFE-S-02: 23.62" w x 23.62" h
- VFE-S-03: 35.43" w x 35.43" h
- VFE-S-04: 47.24" w x 47.24" h
- VFE-S-05: 59.06" w x 59.06" h

**Rectangle Sizes:**

- VFE-R-01: 11.8" w x 23.62" h
- VFE-R-02: 11.8" w x 35.43" h
- VFE-R-03: 23.62" w x 35.43" h
- VFE-R-04: 23.62" w x 47.24" h



**Features Include:**

- slim, lightweight 3/4" aluminum frame
- easy-to-apply push-fit fabric graphic
- direct to wall mounting
- custom frame sizes available



*use as posters in a retail setting*



*use as directional signs*



*use as advertisements*



All Vector Frame displays are made in North America and have a limited lifetime hardware warranty.

# VECTOR FRAME™ | 10' ESSENTIAL EXHIBIT KITS

## VECTOR FRAME 10' ESSENTIAL EXHIBIT KITS

Stand apart from the competition with a clean, sophisticated 10' x 10' or 10' x 20' Vector Frame™ exhibit kit. These graphic mural kits feature square-corner 2" extrusion frames and push-fit fabric graphics that cover the entire frame. Vector Frame Essential kits are easy to assemble and disassemble.



**KIT 01**  
VF-K-01



**KIT 02**  
VF-K-02



**KIT 03**  
VF-K-03



**KIT 04**  
VF-K-04



*easy to apply push-fit fabric graphics*

\*Counters in foreground included in purchased kits.



All Vector Frame displays are made in North America and have a limited lifetime hardware warranty.



KIT 05  
VF-K-05



KIT 06  
VF-K-06



KIT 07  
VF-K-07



KIT 08  
VF-K-08



Vector Frame counter tops are available in your choice of four thermoform finishes



OCH2 & OCE  
wheeled molded cases included with each kit (page 141-142)

\*Counters in foreground included in purchased kits.

# VECTOR FRAME™ | 10' MASTER EXHIBIT KITS

## VECTOR FRAME 10' MASTER EXHIBIT KITS

The innovative, contemporary and clean appearance of the Vector Frame™ Master line of exhibit kits will captivate your audience. Kits feature push-fit fabric graphics, easy-to-assemble extrusion frames, accent lighting, tables, counters, literature accessories, monitor mounts and interior LED edge lighting where indicated. Customized kits are also available.



**KIT 09**  
VF-K-09



**KIT 10**  
VF-K-10



**KIT 11**  
VF-K-11



**KIT 12**  
VF-K-12



*easy to apply push-fit fabric graphics*

\*Counters in foreground included in purchased kits.



All Vector Frame displays are made in North America and have a limited lifetime hardware warranty.



**KIT 13**  
VF-K-13



**KIT 14**  
VF-K-14



**KIT 15**  
VF-K-15



**KIT 16**  
VF-K-16\*



Vector Frame counter tops are available in your choice of four thermoform finishes



silver black mahogany natural



**OCH2 & OCE**  
wheeled molded cases included with each kit (page 141-142)

\*Monitors not included.

\*Counters in foreground included in purchased kits.

VECTOR FRAME 20' MASTER EXHIBIT KITS

The innovative, contemporary and clean appearance of the Vector Frame™ line of exhibit kits will captivate your audience. Kits feature push-fit fabric graphics, easy-to-assemble extrusion frames, accent lighting, tables, counters, literature accessories, monitor mounts and interior LED edge lighting where indicated.



KIT 17  
VF-K-17

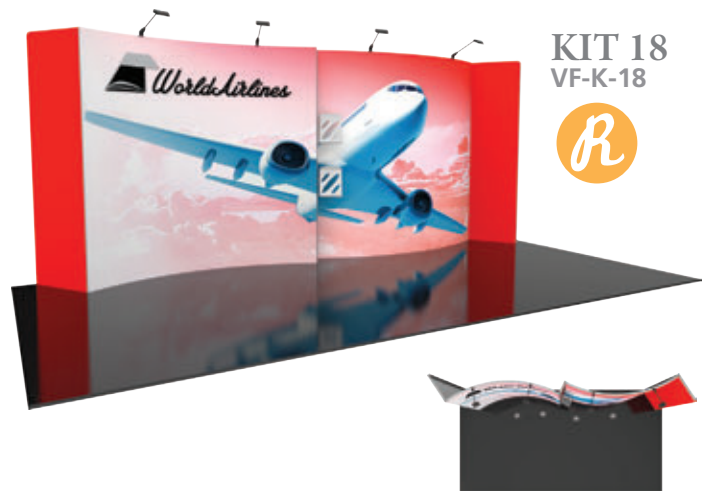

KIT 18  
VF-K-18

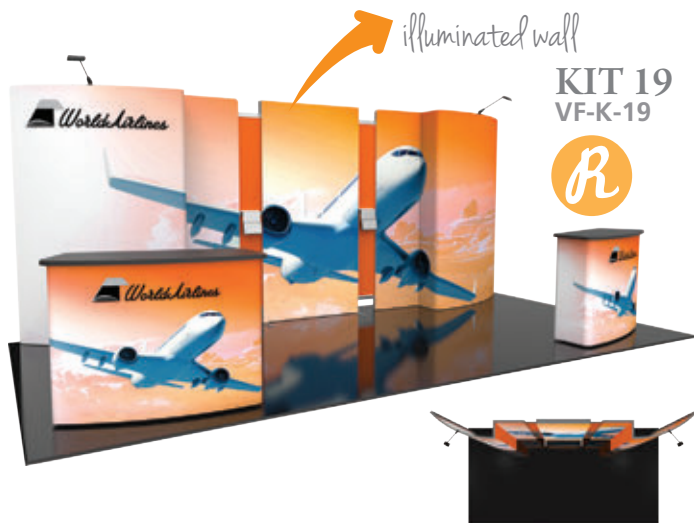

illuminated wall

KIT 19  
VF-K-19



KIT 20  
VF-K-20



easy to apply push-fit fabric graphics

\*Counters in foreground included in purchased kits.



All Vector Frame displays are made in North America and have a limited lifetime hardware warranty.

KIT 21  
VF-K-21\*

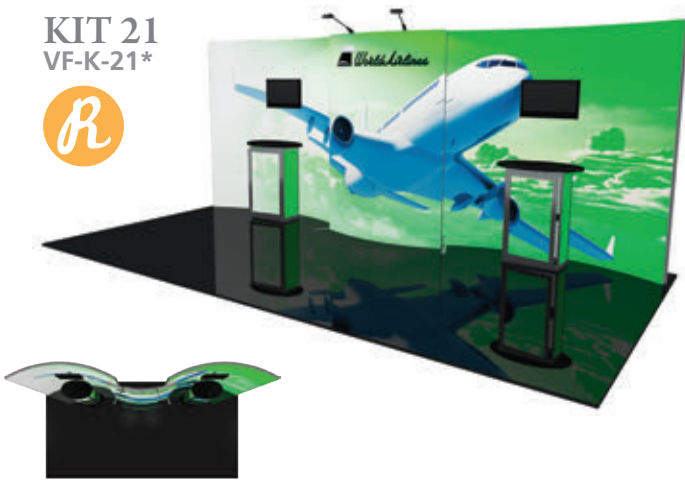

KIT 22  
VF-K-22\*



KIT 23  
VF-K-23

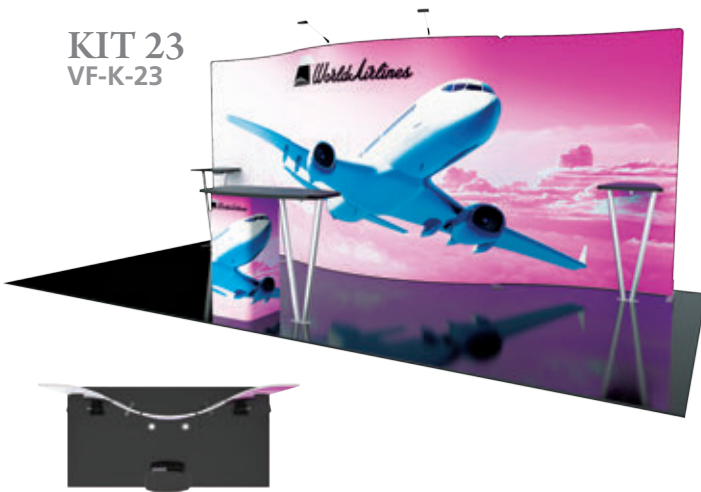

KIT 24  
VF-K-24\*

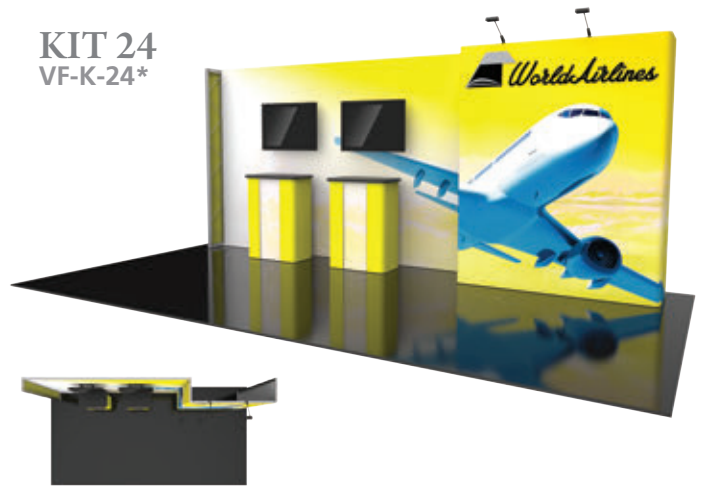

Vector Frame counter tops are available in your choice of four thermoform finishes



silver black mahogany natural



**OCH2 & OCE**  
wheeled molded cases included with each kit (page 141-142)

Full line of counters shown on page 132.

\*Counters in foreground included in purchased kits. Monitors not included.

VECTOR FRAME TABLETOPS

Vector Frame™ Tabletop Kits provide modern and dynamic flare to your marketing message. The silicone edge (SEG) push-fit fabric graphics and extrusion-based displays are simple, lightweight and take minutes to assemble. Units come in a sturdy case. Customized units also available.



**KIT 01**  
**VF-K-TT-01**

5' tabletop  
footprint dimensions:  
55.5" w x 31.75" h x 11.81" d



**KIT 02**  
**VF-K-TT-02**

5' tabletop  
footprint dimensions:  
61.3" w x 31.77" h x 11.81" d



**KIT 03**  
**VF-K-TT-03**

4 1/2' tabletop  
footprint dimensions:  
56.14" w x 39.6" h x 17.09" d



**KIT 04**  
**VF-K-TT-04**

8' tabletop  
footprint dimensions:  
95.7" w x 41.6" h x 11.81" d



easy to apply push-fit fabric graphics



**OCS**  
wheeled molded  
cases included  
with each kit  
(page 141)



All Vector Frame displays are made in North America and have a limited lifetime hardware warranty.

Vector Frame counter tops are available in your choice of four thermoform finishes



VECTOR FRAME COUNTERS

Vector Frame™ counters complement the Vector Frame series of exhibit kits, but are also ideal for any stand-alone event or display. Vector Frame counters couple simple extrusion-based frames with push-fit fabric graphics or rigid sintra graphics. Tables are available in four colored finishes – silver, black, mahogany and natural. Counters fit in an OCH2 portable shipping case and allow for accessible storage by removing one fabric panel. Custom sizes also available.



**VECTOR FRAME COUNTER 01**

VFC-01

39.37" w x 36.61" h x 22.44" d



**VECTOR FRAME COUNTER 02**

VFC-02

55.5" w x 40.5" h x 22.5" d



**VECTOR FRAME COUNTER 03**

VFC-03

38.5" w x 40.5" h x 19.88" d



**VECTOR FRAME COUNTER 04**

VFC-04

30.63" w x 40.5" h x 18.75" d



**VECTOR FRAME COUNTER 05**

VFC-05

39.76" w x 40.5" h x 22.75" d  
- features locking door and rigid sintra graphics



**VECTOR FRAME COUNTER 06**

VFC-06

41.63" w x 40.5" h x 20.75" d  
- features locking door and rigid sintra graphics



**VECTOR FRAME COUNTER 07**

VFC-07

46" w x 40.5" h x 22.64" d

**LINEAR PRO MODULAR DISPLAY SYSTEMS**

Linear™ Pro modular display kits provide a modern, slick and stylish appearance. The extrusion based exhibits feature Velcro-applied fabric graphics. Headers and wings available in UV printed graphics or clear plex. Canopy is available in solid stock black, silver or white. Kits come with a fabric graphic canopy, two lights and ship in durable storage cases. Options include LCD monitor mounts, tables, counters, literature pockets and larger freight cases. Customized units also available.

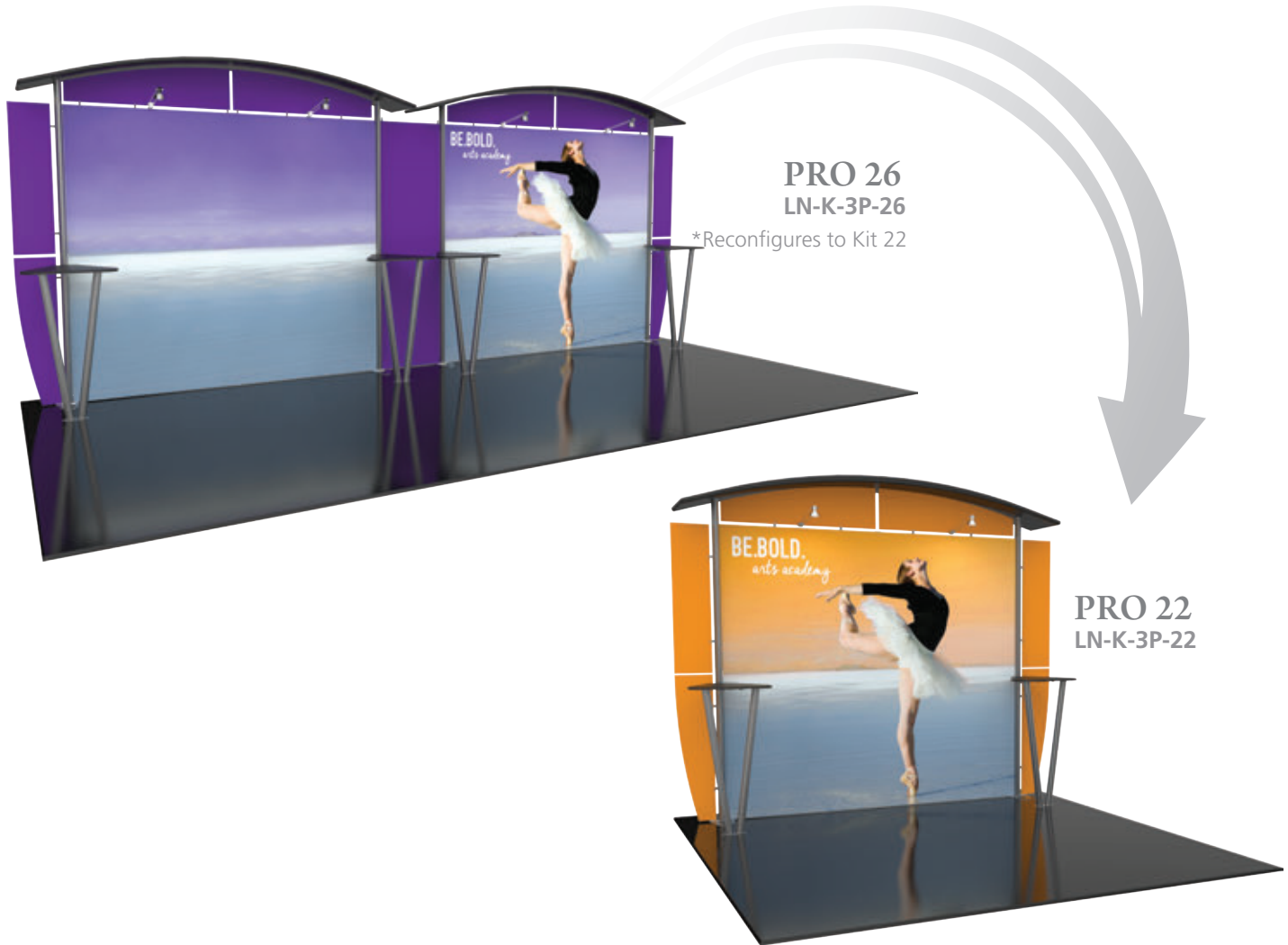

**PRO 26**  
**LN-K-3P-26**

\*Reconfigures to Kit 22

**PRO 22**  
**LN-K-3P-22**

**LINEAR COUNTER**  
**LN-TBL-SA-RCT**

- 3 graphic panels to display custom graphics
- quick & easy-to-assemble, tool included
- fits in an OCH shipping and transport case
- aluminum design is sturdy and stable
- available in all four laminate finishes



Linear counter tops are available in your choice of four thermoform finishes



silver black mahogany natural



LINEAR PRO MODULAR DISPLAY SYSTEMS



**PRO 27**  
LN-K-3P-27

\*Reconfigures to Kit 25



**PRO 25**  
LN-K-3P-25

LINEAR UNIVERSAL ACCESSORIES



**CLAMP**  
UC-EXT



**TABLET HOLDER**  
UC-VESA-BRKT-01



**LIT HOLDER BRACKET**  
UC-LIT-BRKT-ABH-02  
UC-LIT-BRKT-ABH-03



**SHELF BRACKET**  
UC-SHLF-BRKT-01-CIR  
UC-SHLF-BRKT-02-TRI  
UC-SHLF-BRKT-03-SQU

Top and side accents, lighting and tables included in kit.  
\*10' x 20' kits reconfigure to 10' x 10' sizes.

LINEAR PRO COUNTERS

Linear™ counters add function and flare to any space. Extrusion based construction coupled with your choice of rigid graphic infill panels or frosted plex panels make these kiosks sturdy and versatile. Counter tops are available in four thermoform finishes – silver, black, mahogany and natural. Printed graphic panels create the base of the counter. **Counters come standard with locking cabinet door.**



LN-CU-01



LN-CU-02



LN-CU-03



LN-CU-05



LN-CU-06



LN-CU-07

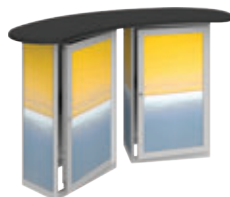

LN-CU-08

Linear counter tops are available in your choice of four thermoform finishes



silver black mahogany natural







**LINEAR COUNTER**  
LN-TBL-SA-RCT-1

- 3 graphic panels to display custom graphics
- quick & easy-to-assemble, tool included
- fits in an OCH shipping and transport case
- aluminum design is sturdy and stable
- features a locking door
- top available in four laminate finishes



**LINEAR KIOSK 01**  
LN-K-01

- 54.4" w x 99" h x 23.25" d
- monitor\* mount
- fabric canopy
- approximate weight: 125 lbs



**LINEAR KIOSK 05**  
LN-K-05

- 25.38" w x 72.25" h x 18.5" d
- monitor\* mount
- approximate weight: 30 lbs



Linear kiosks 01 and 05 come with an OCH case (page 142)



Linear kiosk counter tops are available in your choice of four thermoform finishes



silver black mahogany natural

\*Monitor not included.





MERCHANDISE EXPRESS KIT 04  
ME-K-04



## MERCHANDISE EXPRESS MODULAR

The sharp, modern appearance of the Merchandise Express™ portable point-of-purchase display system will turn heads in any retail space, in-store environment or tradeshow space.

The Merchandise Express series is a collection of angular shaped displays that feature easy-to-assemble aluminum frames, push-fit fabric graphics, and shelves and pegboards designed to house and display lightweight merchandise. Kits come with interchangeable accessories - monitor mounts, shelving, pegboards and lighting where indicated.

The lightweight black aluminum frame pieces slide and quickly lock together. No tools are required for assembly, making Merchandise Express a durable, simple and effective selling tool. Display frames come with a one-year limited warranty. Push-fit fabric graphics are made in North America—printed on state-of-the-art large format printing equipment and hand-finished by skilled professionals.

The versatile Merchandise Express kits can reconfigure into a variety of different sizes and can be further customized to create uniquely tailored display solutions.

## COMBINE MESSAGING AND MERCHANDISE WITH AN IMPACT!



Merchandise Express Kit 04



Merchandise Express Kit 07



Merchandise Express Kit 02

## MERCHANDISE EXPRESS POINT OF PURCHASE

Merchandise Express™ is a portable point of purchase display system that features simple black metal frames, shelving, pegboards and push-fit graphics to deliver products and messaging with an impact! Convenient rolling carry bags make transportation easy.



**KIT 01**  
**ME-K-01**

- 9 ½'w full height straight backwall
- 3 Lumina 200 LED lights



**KIT 02**  
**ME-K-02**

- 9 ½'w full height straight backwall
- 1 monitor\* mount supports 50" monitor; max weight = 30 lbs
- 2 Lumina 200 LED lights

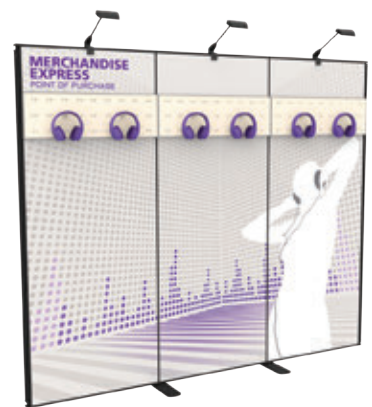

**KIT 03**  
**ME-K-03**

- 9 ½'w full height straight backwall
- 3 pegboards; max weight per board = 10 lbs
- 3 Lumina 200 LED lights

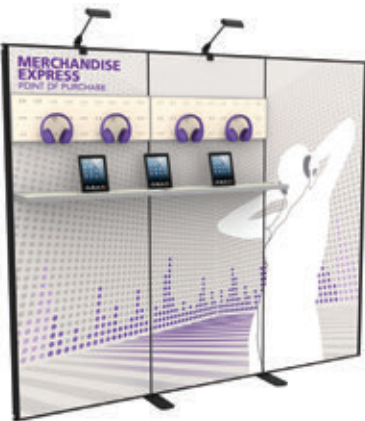

**KIT 04**  
**ME-K-04**

- 9 ½'w full height straight backwall
- 2 pegboards; max weight per board = 10 lbs
- 2 adjustable height shelves; max weight per shelf = 10 lbs
- 2 Lumina 200 LED lights

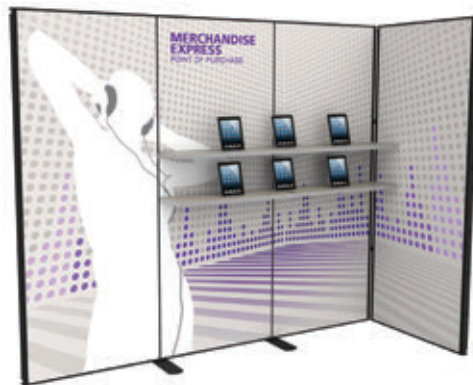

**KIT 05**  
**ME-K-05**

- 9 ½'w full height straight backwall
- 1 side wall
- 4 adjustable height shelves; max weight per shelf = 10 lbs

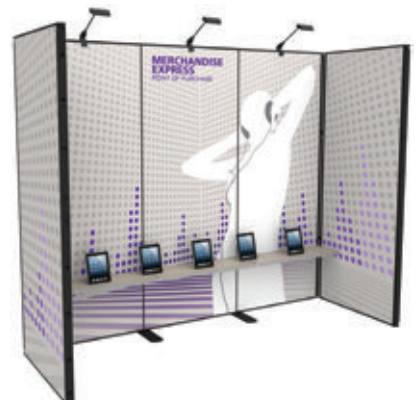

**KIT 06**  
**ME-K-06**

- 9 ¾'w full height straight backwall
- 2 side walls
- 3 adjustable height shelves; max weight per shelf = 10 lbs
- 3 Lumina 200 LED lights

\*Monitors, tablets and accessories not included.



**MERCHANDISE EXPRESS  
POINT OF PURCHASE**



**KIT 07**  
**ME-K-07**

- 19'w full height straight backwall
- 4 pegboards; max weight per board = 10 lbs
- 2 Lumina 200 LED lights



**KIT 08**  
**ME-K-08**

- 19'w full height straight backwall
- 2 pegboards; max weight per board = 10 lbs
- 8 adjustable height shelves; max weight per shelf = 10 lbs
- 2 Lumina 200 LED lights



**KIT 09**  
**ME-K-09**

- 19'w full height straight backwall
- 4 pegboards; max weight per board = 10 lbs
- 4 adjustable height shelves; max weight per shelf = 10 lbs
- 2 Lumina 200 LED lights



**KIT 10**  
**ME-K-10**

- 19'w full height straight backwall
- 1 monitor\* mount supports 50" monitor; max weight = 30 lbs
- 2 side walls
- 2 pegboards; max weight per board = 10 lbs
- 2 adjustable height shelves; max weight per shelf = 10 lbs

\*Monitors and accessories not included.

# ORBITAL EXPRESS™ TRUSS | INTRODUCTION



LYNX  
OR-K-LX1



## TRUSS

The bold, contemporary, industrial look of Orbital Express™ Truss exhibits dominates the show floor.

The Orbital Express Truss series is a collection of reconfigurable exhibit backwalls, islands and counters that feature a fixed number of parts and connectors. NO TOOLS are required for assembly; 20' x 20' and 10' x 20' inline kits transition into smaller size exhibits, counters and more.

The versatility and value of the Orbital Express Truss system is unmatched! Set-up and installation of Orbital Express Truss exhibits, backwalls and accessories is easy – simply twist & lock is all you have to do. All Orbital Express Truss display pieces are quality crafted and manufactured in North America. All fabric and UV-panel graphics are produced in North America, printed on state-of-the-art, G7 color certified printers, and are finished by hand.

With endless designs and options to choose from, you are certain to find a solution that fits your needs. You can also easily customize your own Orbital Express Truss exhibit and make it completely unique.

## THE ORBITAL EXPRESS TRUSS SYSTEM IS **VERSATILE, RECONFIGURABLE & EASY!**

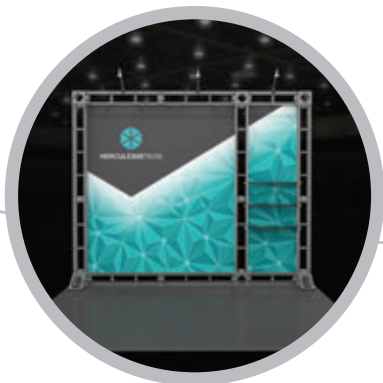

Hercules 08



Magellan

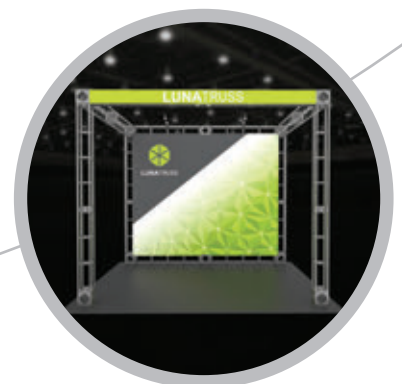

Luna 01

# ORBITAL EXPRESS™ TRUSS | 10' x 10' HERCULES KITS

## 10' HERCULES KITS

The Hercules line of Orbital Express™ Truss features basic backwalls and kits in a variety of sizes to suit a range of space needs. A benefit to this versatile system is that it enables you to reconfigure kits in multiple ways and combinations using the same parts. Simply add or subtract from any Hercules kit to create a new appearance for every event or tradeshow!

Truss counter tops are available in your choice of four thermoform finishes

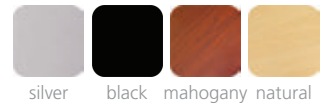

**HERCULES 03**  
OR-K-HC03



**HERCULES 08**  
OR-K-HC08

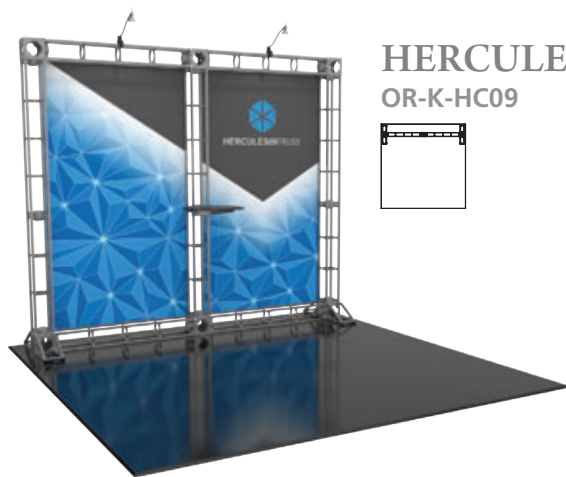

**HERCULES 09**  
OR-K-HC09

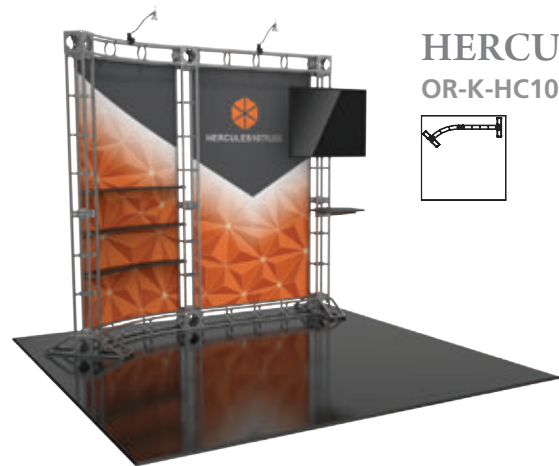

**HERCULES 10**  
OR-K-HC10\*



Easily add an accessory wire/hanging rack to your kit!  
See p. 210 for more.





HERCULES 12  
OR-K-HC12

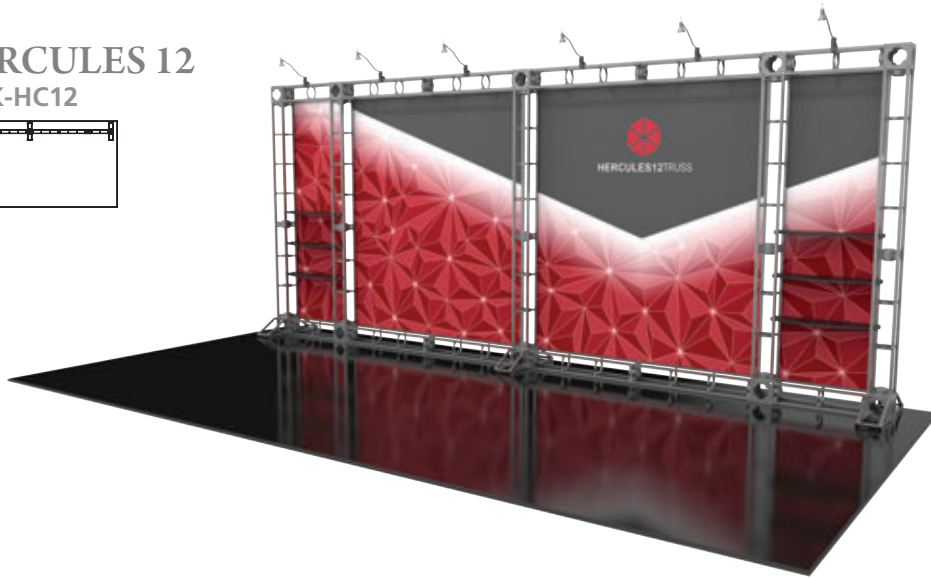
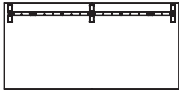

HERCULES 13  
OR-K-HC13

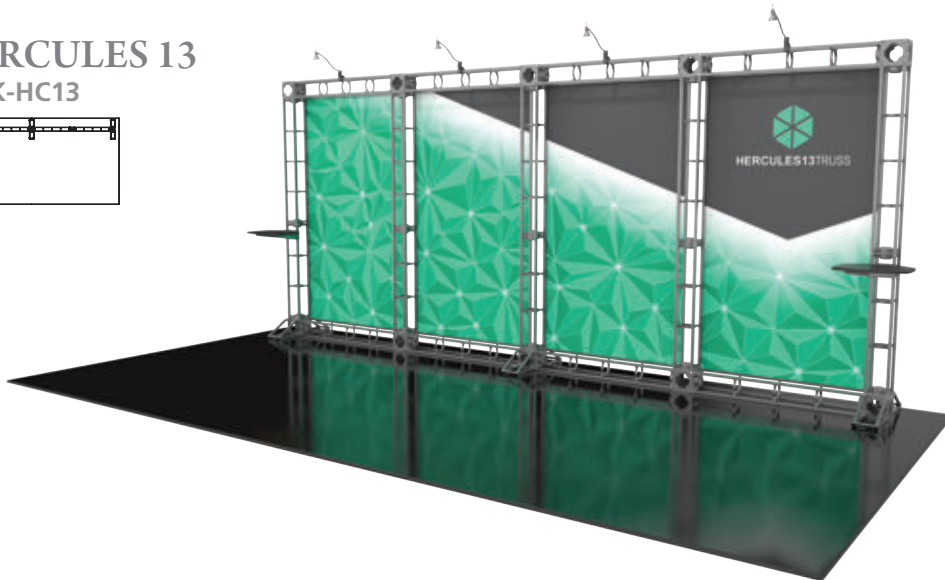

HERCULES 15  
OR-K-HC15\*

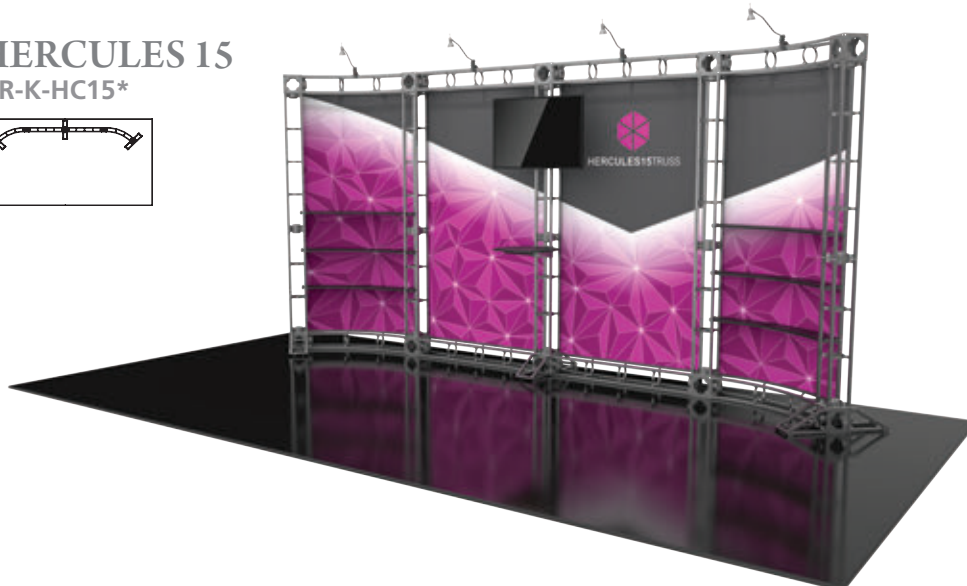

\*Monitors not included.

**10' EXHIBIT KITS**

Orbital Express™ Truss features over 40 professionally designed “off the shelf” kits for a variety of booth sizes and configurations. Each kit comes complete with all the parts, fixtures and fittings you need to create a successful exhibit, including (depending on the kit) low voltage spotlights and adjustable tabletops. A benefit to this versatile system is that it enables you to reconfigure kits in multiple ways and combinations using the same parts. Orbital Express Truss can also be easily configured to fit your custom needs!



**CLIO**  
OR-K-CO1\*



**LUNA 10**  
OR-K-LU1

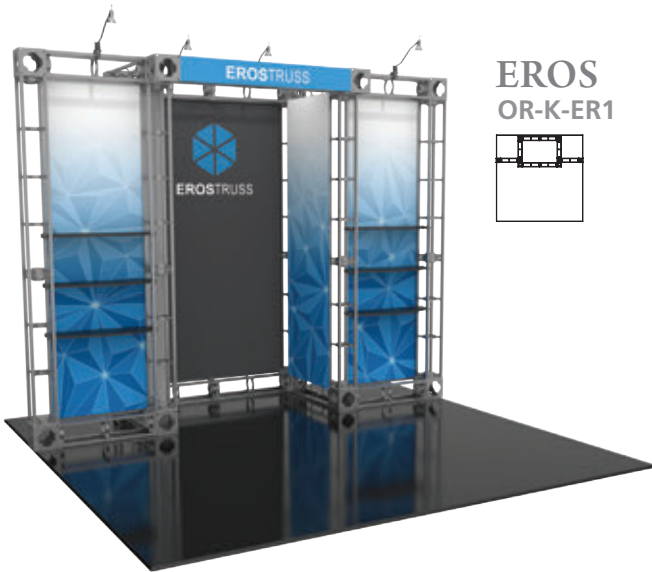

**EROS**  
OR-K-ER1

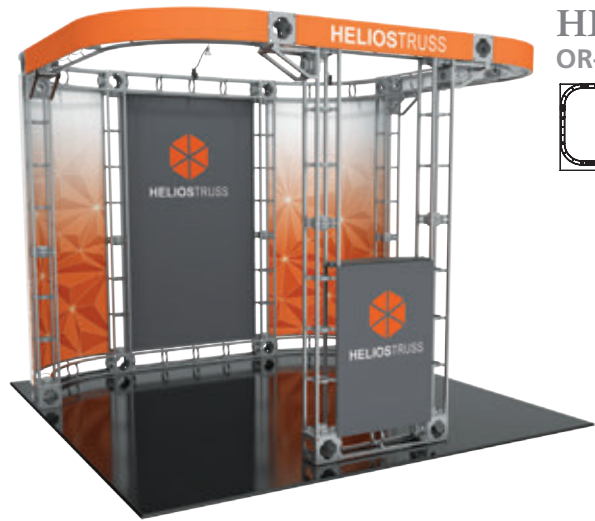

**HELIOS**  
OR-K-HE1



*Easily add an accessory wirehanging rack to your kit!  
See p. 210 for more.*

\*Monitors not included.



Truss counter tops are available in your choice of four thermoform finishes

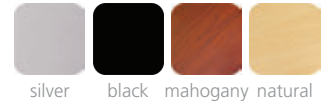

**LYRA**  
OR-K-LY2  
corner kit



**METIS**  
OR-K-MT1\*

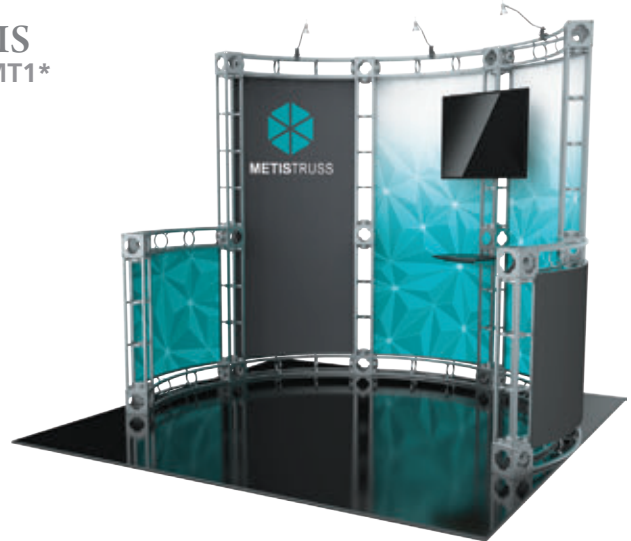

**SIRIUS**  
OR-K-SR1

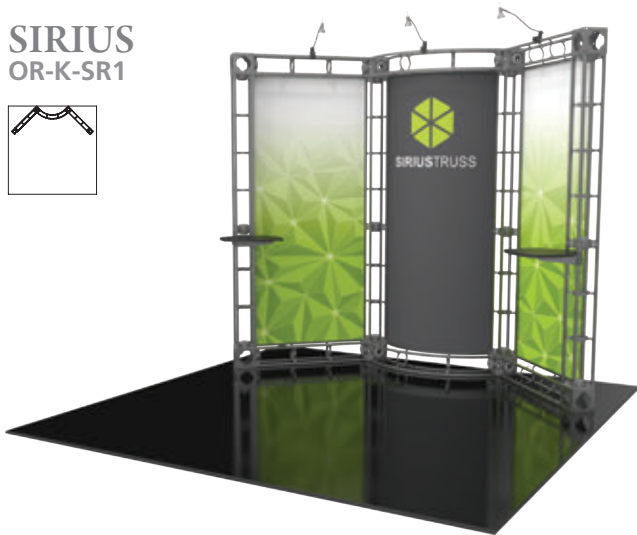

**CYGNUS**  
OR-K-SYG2  
corner kit



Easily add a counter or podium to your kit!  
See p. 209 for more.

\*Monitors not included.



# ORBITAL EXPRESS™ TRUSS | 10' x 10' EXHIBIT KITS

## 10' EXHIBIT KITS

Orbital Express™ Truss features over 30 professionally designed “off the shelf” kits for a variety of booth sizes and configurations. Each kit comes complete with all the parts, fixtures and fittings you need to create a successful exhibit, including (depending on the kit) low voltage spotlights and adjustable tabletops. A benefit to this versatile system is that it enables you to reconfigure kits in multiple ways and combinations using the same parts. Orbital Express Truss can also be easily configured to fit your custom needs!

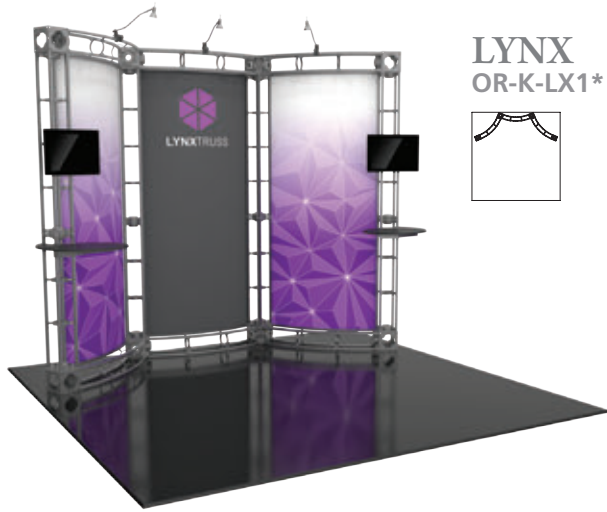

**LYNX**  
OR-K-LX1\*

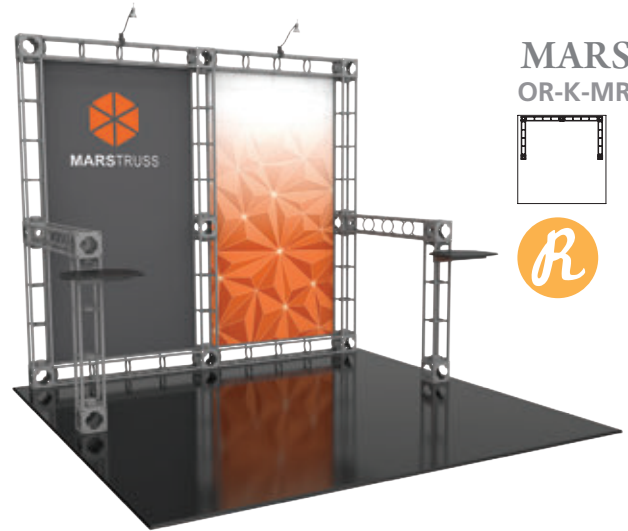

**MARS**  
OR-K-MR1

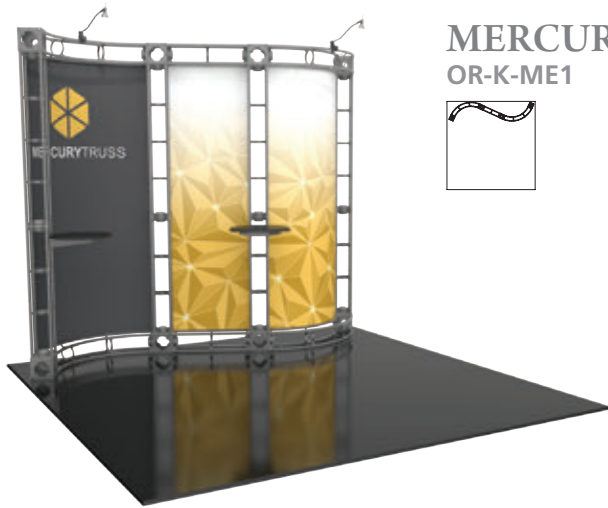

**MERCURY**  
OR-K-ME1

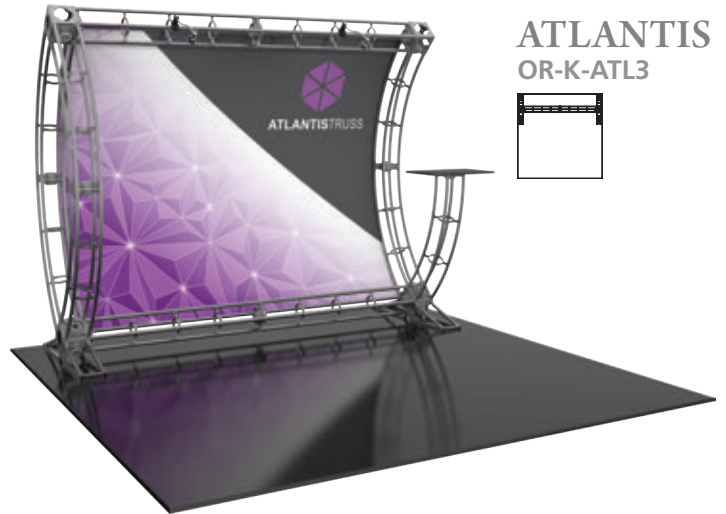

**ATLANTIS**  
OR-K-ATL3



Truss counter tops are available in your choice of four thermoform finishes



silver black mahogany natural



# RECONFIGURE INTO MULTIPLE SIZES



Easily convert the Corvus 20' x 20' Truss kit to a Polaris 10' x 20' style inline.

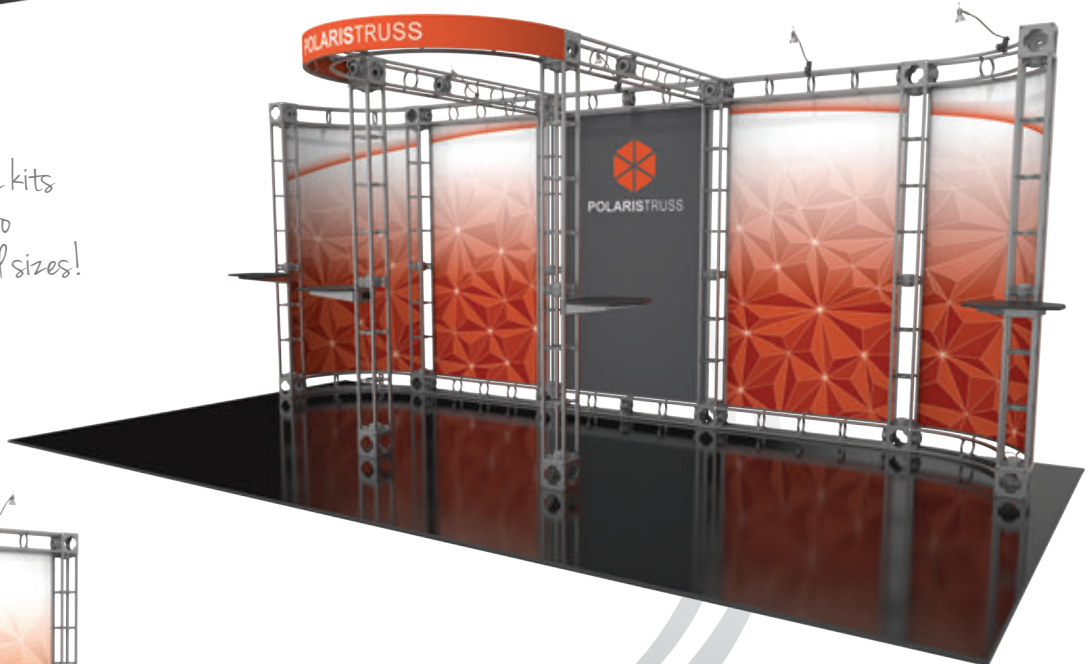

Ask about the many kits that reconfigure into different styles and sizes!

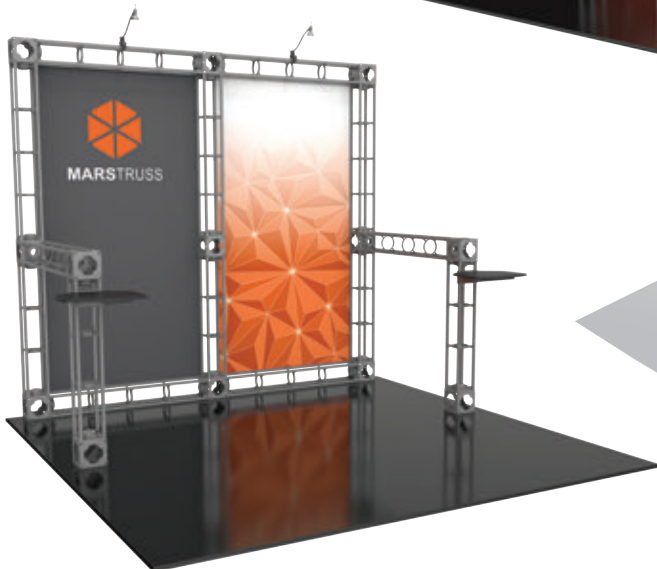

Then, convert the Polaris 10' x 20' kit into a Mars 10' x 10' kit configuration using existing parts.

# ORBITAL EXPRESS™ TRUSS | 10' x 20' EXHIBIT KITS

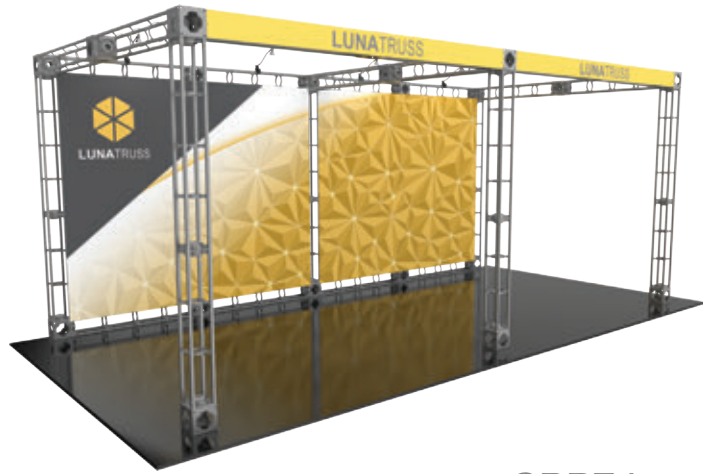

**LUNA 20**  
**OR-K-LU2**

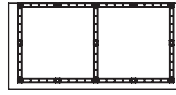

**ORBEA**  
**OR-K-OB1**

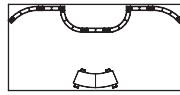

\*includes counter

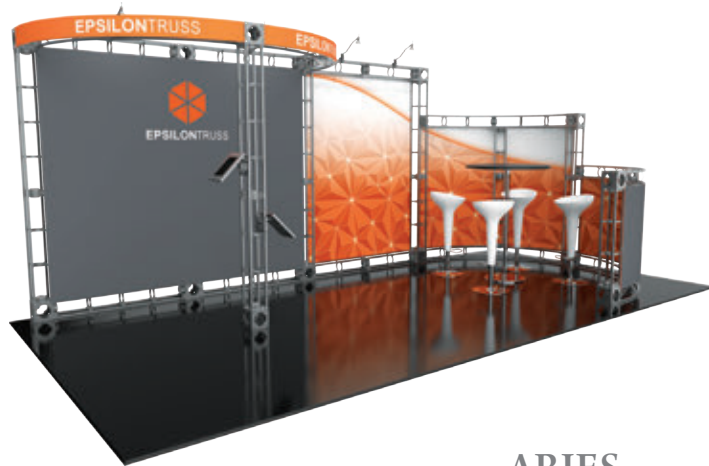
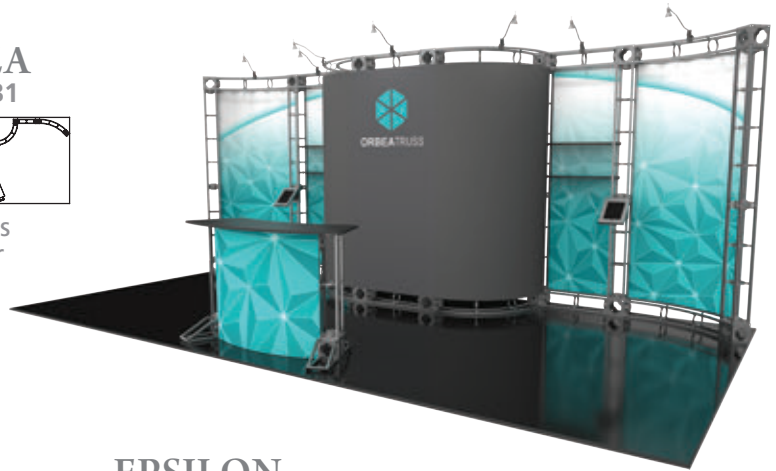

**EPSILON**  
**OR-K-EP1**

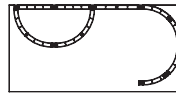

**ARIES**  
**OR-K-A11**

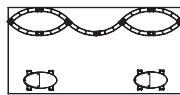

\*includes counters

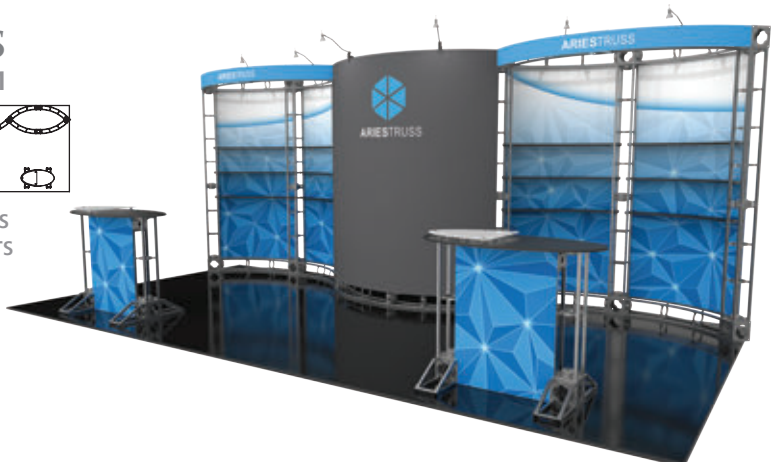

# 10' x 20' EXHIBIT KITS | ORBITAL EXPRESS™ TRUSS

Truss counter tops are available in your choice of four thermoform finishes



## APEX OR-K-AX1\*

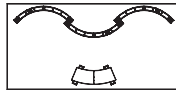

\*includes counter and literature racks

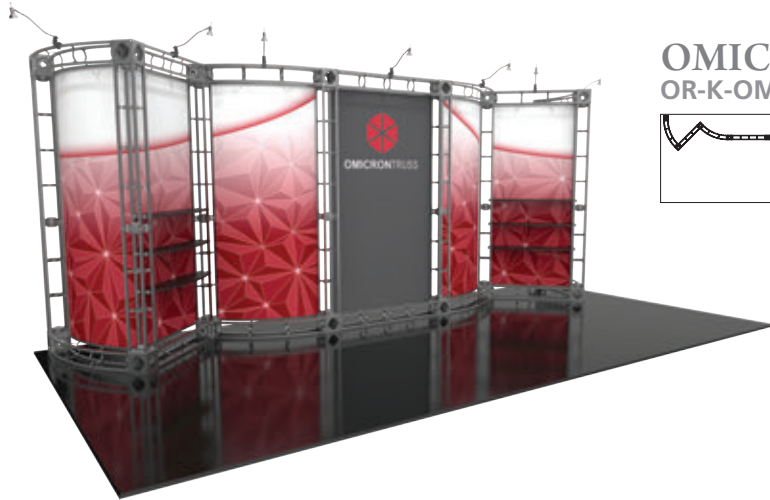
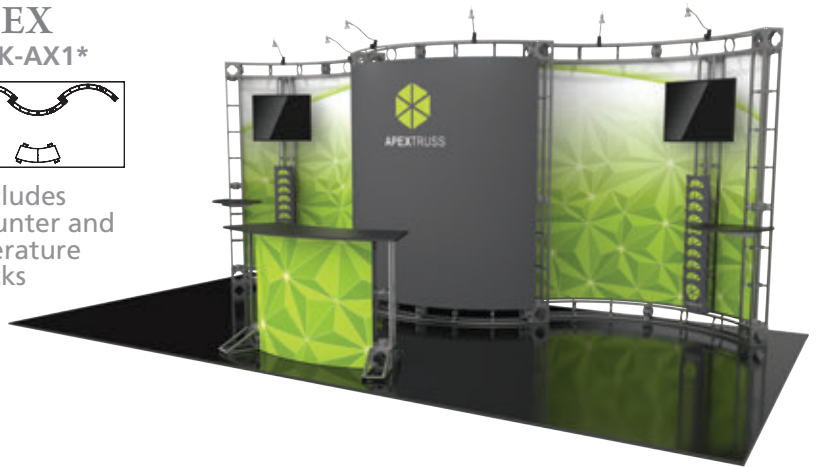

## OMICRON OR-K-OM1

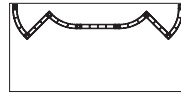

## CALLISTO OR-K-CI1\*

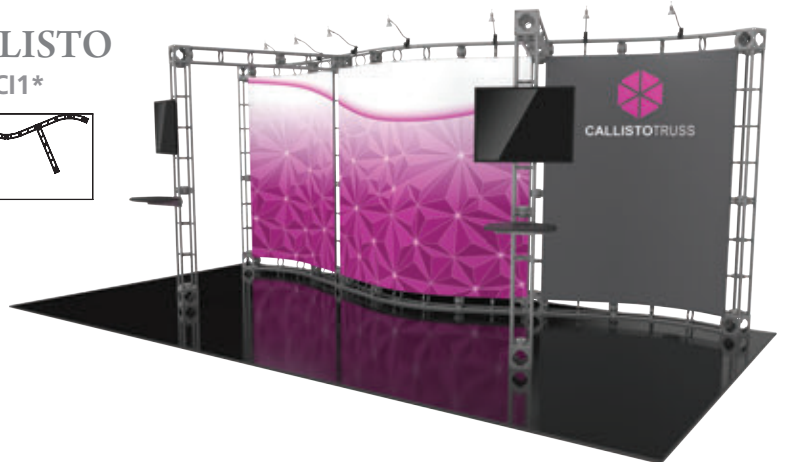
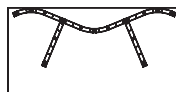

Easily add an accessory wire hanging rack to your kit!  
See p. 210 for more.



\*Counters featured are included. Monitors, iPads and mounts, literature accessories and furniture are not included.

# ORBITAL EXPRESS™ TRUSS | 10' x 20' EXHIBIT KITS

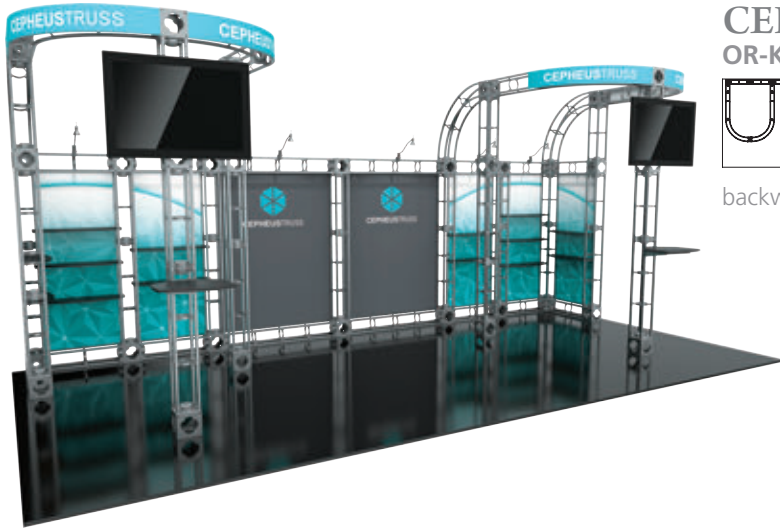

**CEPHEUS-2**  
OR-K-CE1-2\*

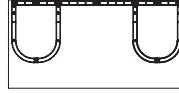

backwall height = 72.5"

**SATURN**  
OR-K-SA1

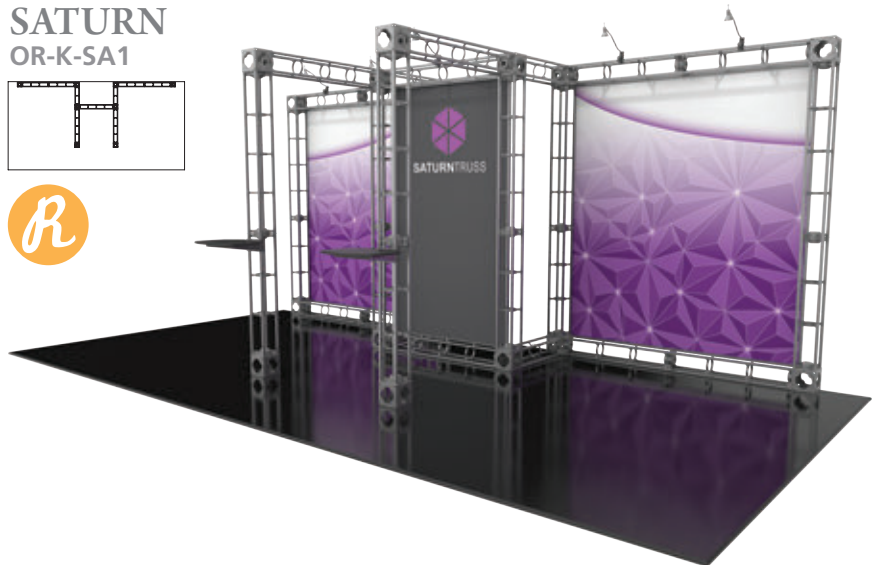
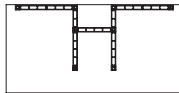

**ANTARES**  
OR-K-AT1

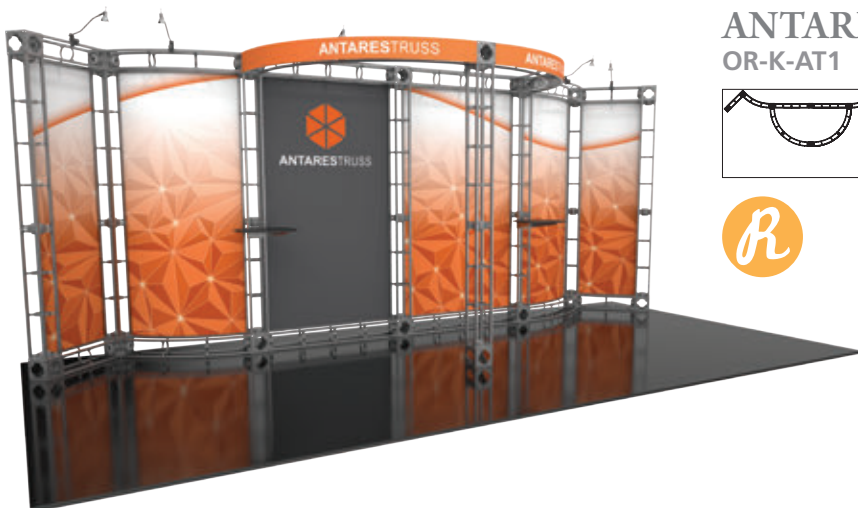
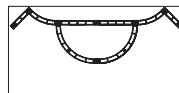

\*Monitors not included.





Truss counter tops are available in your choice of four thermoform finishes



**MAGELLAN**  
OR-K-MG1

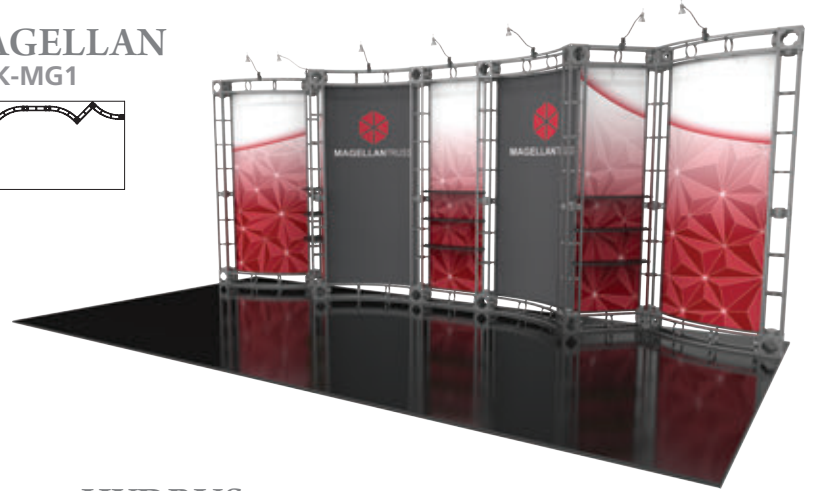
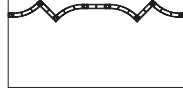

**HYDRUS**  
OR-K-HD1

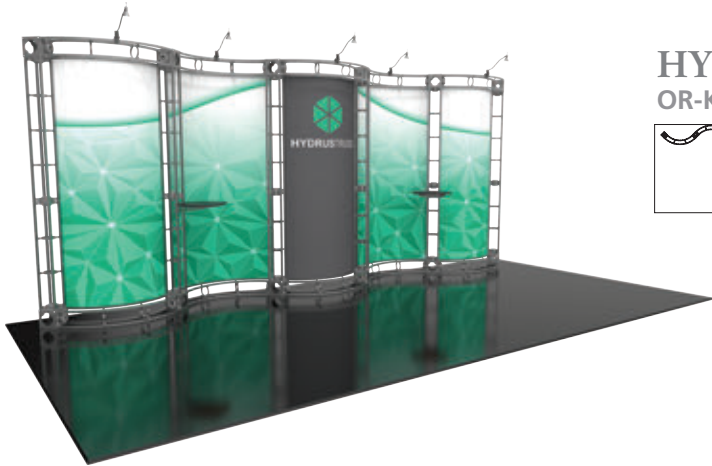
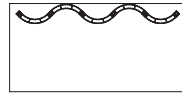

**PHOENIX**  
OR-K-PX1

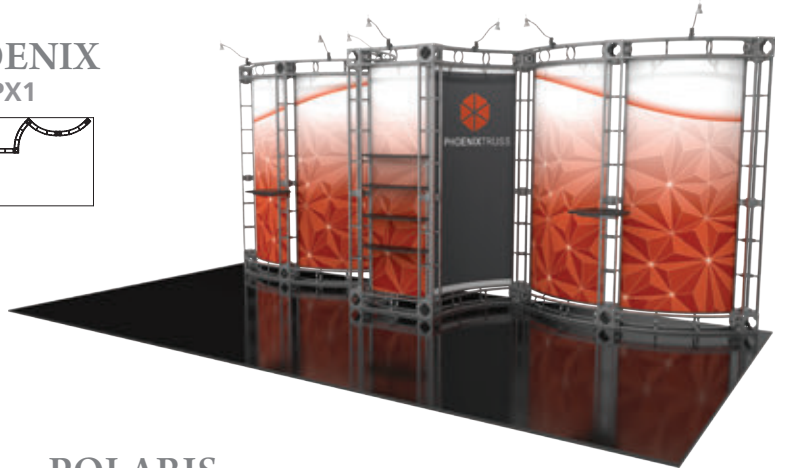
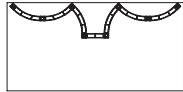

**POLARIS**  
OR-K-PR1

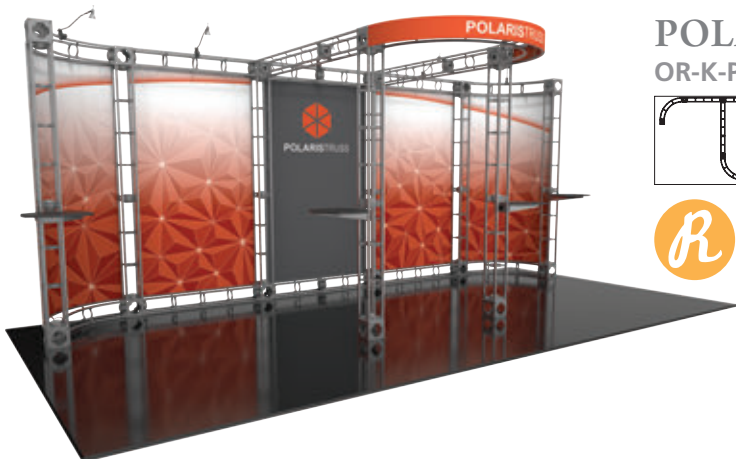
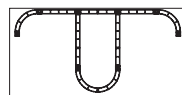

20' ISLAND KITS

Orbital Express™ Truss features over 30 professionally designed “off the shelf” kits for a variety of booth sizes and configurations. Each kit comes complete with all the parts, fixtures and fittings you need to create a successful exhibit, including (depending on the kit) low voltage spotlights and adjustable tabletops. A benefit to this versatile system is that it enables you to reconfigure kits in multiple ways and combinations using the same parts. Orbital Express Truss can also be easily configured to fit your custom needs!



ONYX  
OR-K-ON1

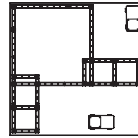

\*includes counters

ATLAS  
OR-K-AS1

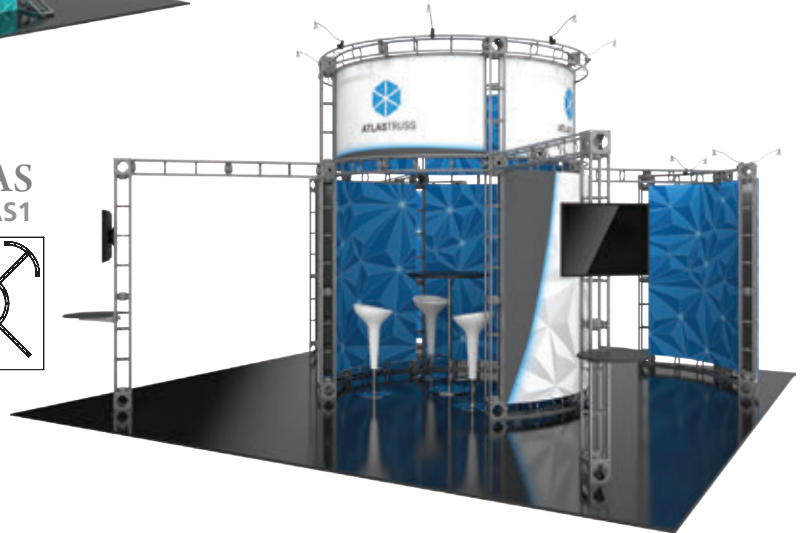
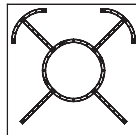

TUCANA  
OR-K-TU1

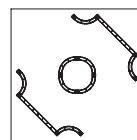

Easily add an accessory wire hanging rack to your kit!  
See p. 210 for more.



# 20' x 20' ISLAND KITS | ORBITAL EXPRESS™ TRUSS

Truss counter tops are available in your choice of four thermoform finishes

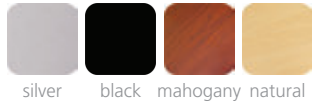

## GEMINI OR-K-GE1

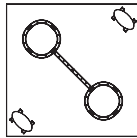

\*includes counters

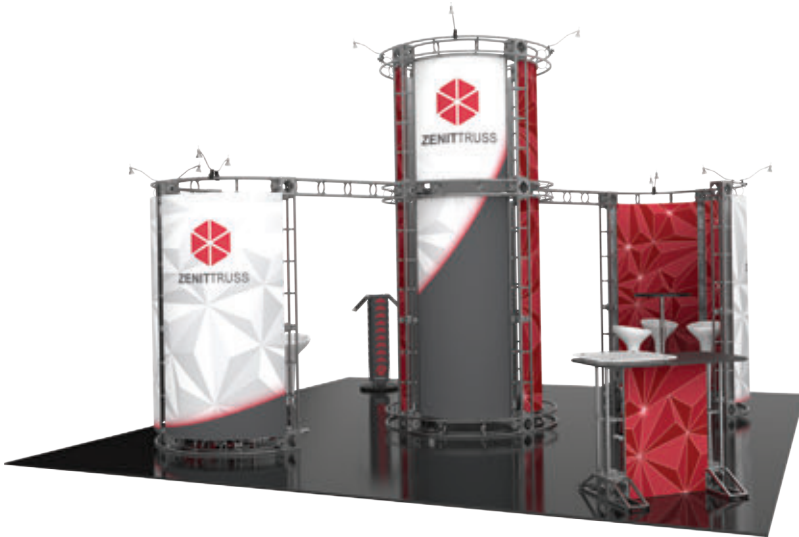

## ZENIT OR-K-ZE1

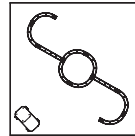

\*includes counter

## CALYPSO OR-K-CL1

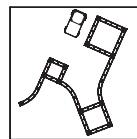

\*includes counter



\*Counters featured are included. Monitors, iPads and mounts, literature accessories and furniture are not included.

# ORBITAL EXPRESS™ TRUSS | 20' x 20' ISLAND KITS

Truss counter tops are available in your choice of four thermoform finishes

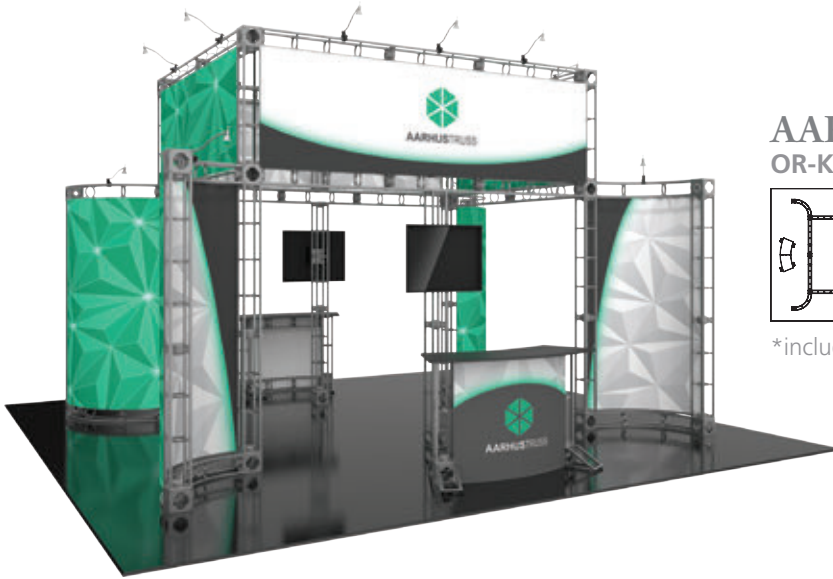

**AARHUS**  
OR-K-AH1

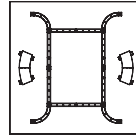

\*includes counters

**VESTA**  
OR-K-VS1

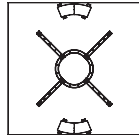

\*includes counter

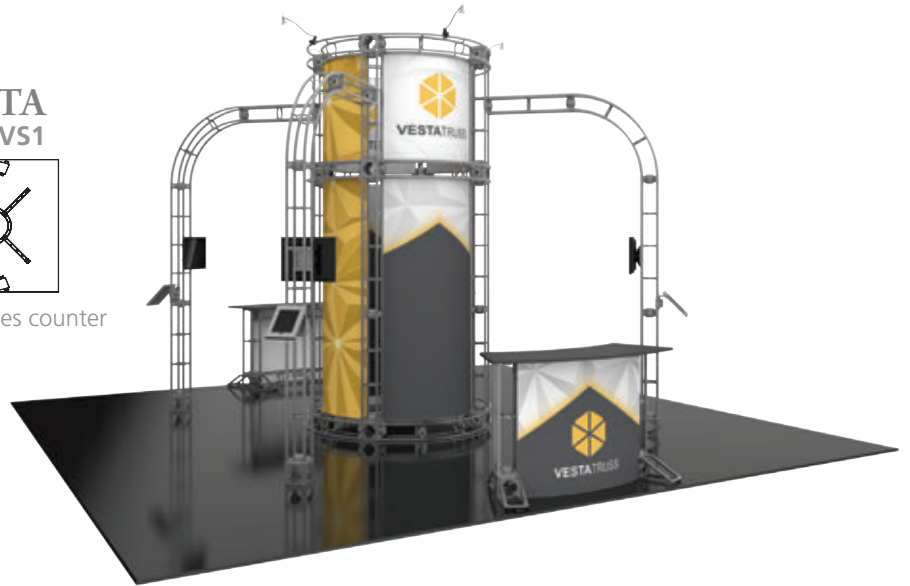

**DORADO**  
OR-K-DO1

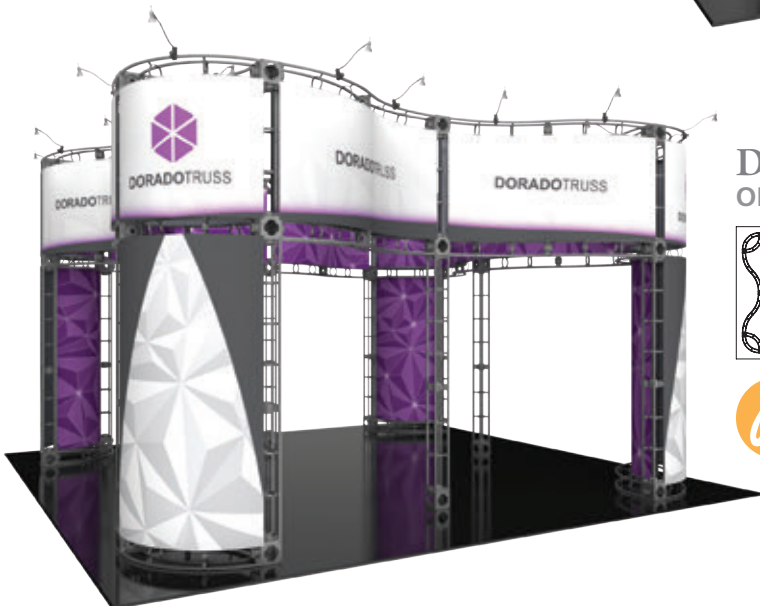
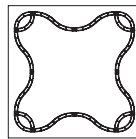

ORBITAL EXPRESS TRUSS | 20' X 20' ISLAND KITS



\*Counters featured are included. Monitors, iPads and mounts, literature accessories and furniture are not included.

20' x 20' ISLAND KITS | **ORBITAL EXPRESS™ TRUSS**



**CORVUS**  
OR-K-CV1

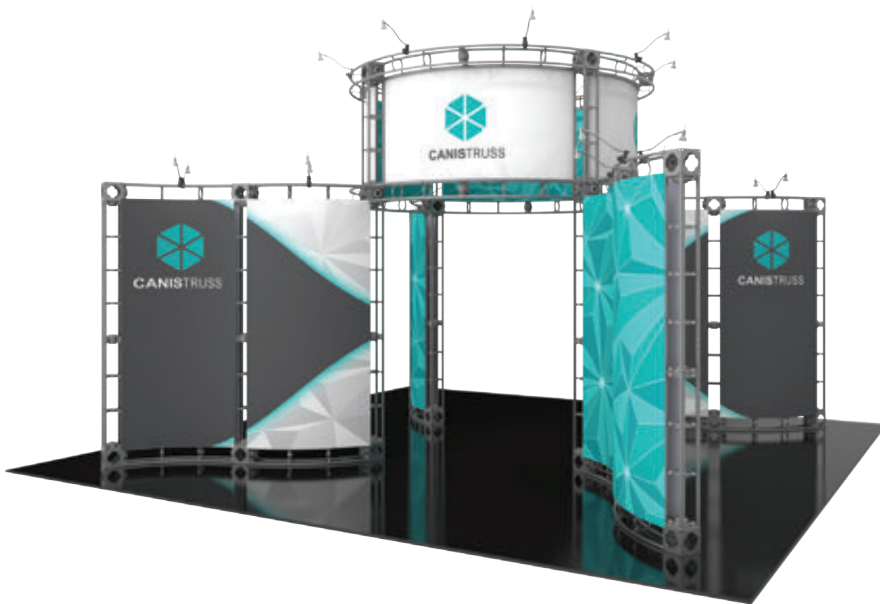
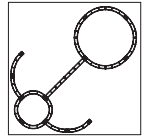

**CANIS**  
OR-K-CA1

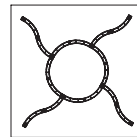

*Easily add an accessory wire hanging rack to your kit!  
See p. 210 for more.*



\*Counters featured are included. Monitors, iPads and mounts, literature accessories and furniture are not included.

## LAMINATE TABLETOPS

Accessories such as tabletops, shelves, literature holders and monitor mounts add functionality and options to your display. Truss tabletops and shelves come in four tabletop colors. No tools needed for assembly.

Truss tabletops & shelving are available in your choice of four thermoform finishes

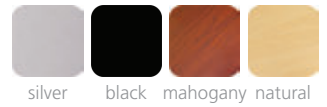

### NATURAL

standard: **OR-TBL-WD**  
 right facing: **OR-TBL2-R-WD**  
 left facing: **OR-TBL2-L-WD**



### MAHOGANY

standard: **OR-TBL-DW**  
 right facing: **OR-TBL2-R-DW**  
 left facing: **OR-TBL2-L-DW**



### SILVER

standard: **OR-TBL-S**  
 right facing: **OR-TBL2-R-S**  
 left facing: **OR-TBL2-L-S**



### BLACK

standard: **OR-TBL-B**  
 right facing: **OR-TBL2-R-B**  
 left facing: **OR-TBL2-L-B**

## INTERNAL SHELVING

- available in choice of four finishes
- 24" straight span, 36" straight span, and 46" straight span shelves available
- 45° curved and 90° curved shelves

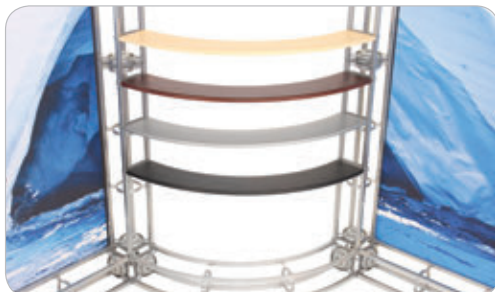

## LIT RACK

### OR-STG



- 10 pocket clamp on literature rack
- note: rack may not fit into the standard kit packaging solution/ molded case
- toolless attachment



COUNTERS AND PODIUMS

Truss Counters and Podiums have several attractive designs to choose from with a sleek plex top as an available option. Choose from four tabletop colors. Graphic options are also available for Truss Counters. No tools needed for assembly.



**RECTANGLE**  
 standard: OR-TC01  
 with plex stand-off and  
 internal shelf: OR-TC01-P



**OVAL**  
 standard: OR-TC02  
 with plex stand-off and  
 internal shelf: OR-TC02-P



**RACETRACK**  
 standard: OR-TC03  
 with plex stand-off and  
 internal shelf: OR-TC03-P



**CURVE**  
 standard: OR-TC04  
 with plex stand-off and  
 internal shelf: OR-TC04-P



**RACETRACK**  
 standard: OR-P04  
 with plex stand-off: OR-P04-P



**SQUARE**  
 standard: OR-P05  
 with plex stand-off: OR-P05-P

Truss counter tops are available in your choice of four thermoform finishes



silver black mahogany natural



**MERCHANDISING RACKS**

Orbital Express Truss Merchandising Racks add functionality and options to any Orbital Truss kit. Accessory options offer multiple configurations and no tools are needed for assembly. Accessories panels are an a la carte add on option for 10ft, 20ft and island Orbital kits. Horizontal support bar needed for proper connection.



**WIRE RACK**

- OR-24-MP**
- OR-36-MP**
- OR-46-MP**

- grid wall with hook brackets
- hook brackets sold separately
- supports approx. 8 lbs. per panel
- OR-24-MP-M mounts to verticals
- horizontal connector required to hang properly (sold separately)



**HANGING RACK**

- OR-36-SP**
- OR-46-SP**

- slot wall with hook brackets
- hook brackets sold separately
- supports approx. 8 lbs. per panel
- horizontal connector required to hang properly (sold separately)



**WIRE/HANGING RACK CONNECTOR**

- OR-24-SST**
- OR-36-SST**
- OR-46-SST**

- required to mount wire and hanging rack
- includes quick lock truss connectors



*Hang your accessory kits with ease!*





Truss table tops and bases are available in your choice of four thermoform finishes

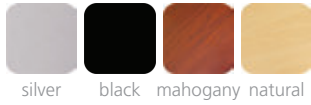

KIOSKS

Orbital Express™ Truss Kiosks are the perfect way to display media and/or literature at any trade show, event, retail or corporate space. Kiosks complement the Orbital Truss Express line of 10', 20' and 20' by 20' displays. Monitors not included. Kiosk table tops and bases available in choice of four thermoform finishes.

**ORBITAL KIOSK 01**  
**OR-KIOSK-01**

- 30" w x 73.75" h x 20" d
- supports 23" monitor\*, max weight = 40 lbs
- rigid graphic = 12" w x 47.25" h x .25" d
- approximate weight = 39 lbs



**ORBITAL KIOSK 02**  
**OR-KIOSK-02**

- 40" w x 73.75" h x 28.25" d
- supports 65" monitor\*, max weight = 80 lbs
- adjustable shelf
- approximate weight = 89 lbs



**ORBITAL KIOSK 06**  
**OR-KIOSK-06**

- 24" w x 56" h x 34" d
- supports 23" monitor\*, max weight = 50 lbs
- table is 20" w x 14" d
- approximate weight = 44 lbs



TRUSS MONITOR MOUNTS



**OPTI-MOUNT 1**  
**OR-SM-MB**

17" - 37" LCD  
max weight = 50 lbs



**OPTI-MOUNT 2**  
**OR-M-MB**

32" - 55" LCD  
max weight = 80 lbs



**OPTI-MOUNT 3**  
**OR-LG-MB**

40" - 65" LCD  
max weight = 150 lbs



**OPTI-MOUNT 4**  
**OR-LG-MB-2**

40" - 65" LCD  
max weight = 150 lbs

\*Monitors and tablets not included.



## FREESTANDING IPAD STANDS

Freestanding tablet stands are smart, lightweight and portable holders used to display tablets or iPads. They can be positioned in either portrait or landscape configurations. Security screws, allen key and bolts make the unit both durable and theft resistant. For extra security, the bases can also be bolted to the floor.



Landscape view



Back

### IPAD STAND

**PAD12-02A-BLACK**  
**PAD12-02A-SILVER**  
**PAD12-02A-WHITE**

- displays iPad 2<sup>nd</sup>, 3<sup>rd</sup>, 4<sup>th</sup> gen and Air models\*
- portrait or landscape
- security screws, allen key and bolts make the unit both durable and theft resistant
- base can be bolted to the floor for extra security
- offered in white, black and silver
- carry bag available as upgrade



## UNIVERSAL TABLET STAND

**PAD21-04**

- displays multiple tablet styles or iPad\*
- portrait or landscape
- security screws, allen key and bolts make the unit both durable and theft resistant
- base can be bolted to the floor for extra security
- features a telescopic, adjustable-height pole, height minimum 28.88" - maximum 49.81" h

## TENSION FABRIC IPAD STANDS

Are you looking to incorporate iPads into your display or environment? Sleekly-designed free standing iPad stands and kiosks make it easy to encourage interactivity, present information and engage your customers in any space. Stands feature stretch fabric graphics.

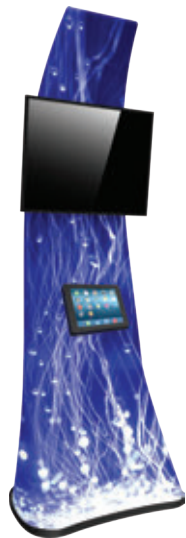

**IPAD STAND 01**  
**TABLET-STD-01**

- 30" w x 84" h x 23" d
- medium monitor mount\*, holds 30" TV/30 lbs max
- iPad holder (2<sup>nd</sup>, 3<sup>rd</sup>, 4<sup>th</sup> gen and Air models)\*
- pillowcase fabric graphic



**IPAD STAND 02**  
**TABLET-STD-02**

- 20.25" w x 85.11" h x 23.8" d
- iPad holder (2<sup>nd</sup>, 3<sup>rd</sup>, 4<sup>th</sup> gen and Air models)\*
- pillowcase fabric graphic



**IPAD STAND 03**  
**TABLET-STD-03**

- 19.98" w x 64.34" h x 15.2" d
- iPad holder (2<sup>nd</sup>, 3<sup>rd</sup>, 4<sup>th</sup> gen and Air models)\*
- pillowcase fabric graphic



**IPAD STAND 04**  
**TABLET-STD-04**

- 26.26" w x 46.26" h x 22.64" d
- iPad holder (2<sup>nd</sup>, 3<sup>rd</sup>, 4<sup>th</sup> gen and Air models)\*
- pillowcase fabric graphic

\*Monitor and tablet not included.



CHARGING STATIONS

Formulate® Charging Stations add technology and great value for visitors in need of a quick charge. Excellent for retail applications, trade shows, and events.



Charging station counters and bases are available in your choice of four thermoform finishes

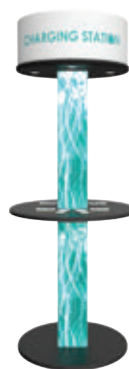
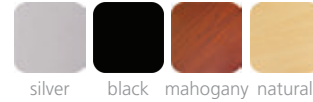

**CHARGING TOWER**  
FMLT-CHRG-01



- 33.56" w x 86.81" h x 33.46" d
- features a circular fabric header for branding and an illuminated fabric center structure
- base and tabletop offered in choice of four laminate color options
- charges virtually all Android, iPod, iPhone, iPad, Micro-USB smartphones, tablets, and devices
- features 16 high-speed charging tips: (8) Micro USB for Android devices and (8) Apple 8-pin for Apple iPhone/iPad/Lightning devices

**CHARGING COUNTER**  
FMLT-CHRG-COUNTER-01



- 23.72" w x 41.54" h x 23.62" d
- features stretch fabric graphic
- tabletop offered in choice of four laminate color options
- charges virtually all Android, iPod, iPhone, iPad, Micro-USB smartphones, tablets, and devices
- features 8 high-speed charging tips: (4) Micro USB for Android devices and (4) Apple 8-pin for Apple iPhone/iPad/Lightning devices



# FORMULATE® | TENSION FABRIC COUNTERS



## FORMULATE COUNTERS

Formulate® counters couple lightweight hardware with state-of-the-art printed stretch silicone edge push-fit fabric graphics to create funky and functional reception stands.



**PILLAR**  
W-01-C



**HALF MOON**  
W-02-C



**ELLIPSE**  
W-03-C



**BULLET**  
W-04-C



**OVAL**  
W-05-C



**BAR**  
W-06-C-04



HALF MOON



ILLUMINATED OVAL



BULLET

SYMPHONY™ COUNTERS

Symphony™ counters provide a unique, sleek design that lends an attractive element to any trade show or POP display. Symphony counters combine extrusion-based hardware with state-of-the-art PRINTED or SOLID COLOR stretch push-fit fabric graphics.



**OVAL**  
SYM-OV



**RECTANGLE**  
SYM-RCT



**BULLET**  
SYM-BLLT



**OVAL DOUBLE GRAND**  
SYM-OV-DBL-GRND



**3 QUAD KIT**  
SYM-QD-3

tension fabric counter tops are available in your choice of finishes



silver black mahogany natural

counter stretch skirts are available in custom printed options as well as the following colors:



amethyst ruby sapphire emerald silver jet



HALF MOON



HALF MOON



HALF MOON

# ACCENTS & ACCESSORIES | COUNTERS

## VECTOR FRAME™ COUNTERS

Vector Frame™ Counters complement the Vector Frame series of exhibit kits, but are also ideal for any stand-alone event or display. Vector Frame counters couple simple extrusion-based frames with push-fit fabric graphics or rigid sintra graphics. Tables are available in four colored finishes – silver, black, mahogany and natural. Counters fit in an OCH2 portable shipping case and allow for accessible storage by removing one fabric panel. Custom sizes also available.

Vector Frame counter tops are available in your choice of four thermoform colors



**VECTOR FRAME COUNTER 01**

**VFC-01**

39.37" w x 36.61" h x 22.44" d



**VECTOR FRAME COUNTER 02**

**VFC-02**

55.5" w x 40.5" h x 22.5" d



**VECTOR FRAME COUNTER 03**

**VFC-03**

38.5" w x 40.5" h x 19.88" d



**VECTOR FRAME COUNTER 04**

**VFC-04**

30.63" w x 40.5" h x 18.75" d



**VECTOR FRAME COUNTER 05**

**VFC-05**

39.76" w x 40.5" h x 22.75" d  
- features locking door and rigid sintra graphics



**VECTOR FRAME COUNTER 06**

**VFC-06**

41.63" w x 40.5" h x 20.75" d  
- features locking door and rigid sintra graphics



**VECTOR FRAME COUNTER 07**

**VFC-07**

46" w x 40.5" h x 22.64" d



Select Hybrid Pro counter bodies are available in your choice of four laminate colors

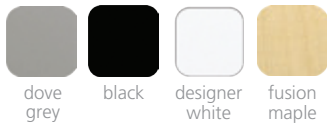

HYBRID PRO™ COUNTERS

All Hybrid Pro™ Modular counters feature accessible storage and locking doors. Printed fabric graphics or rigid infill panels allow for your messaging and branding. Choose the size and counter shape that will match your backwall and space best.



**HYBRID PRO COUNTER 01**  
HPC-01

- 39.38" w x 39.38" h x 17.75" d  
- white laminate cabinet with fabric graphic on the front, opaque or backlit



**HYBRID PRO COUNTER 02**  
HPC-02

- 70.88" w x 39.38" h x 23.63" d  
- white laminate cabinet with fabric graphic on the front, opaque or backlit



**HYBRID PRO COUNTER 03**  
HPC-03

- 39.38" w x 36.63" h x 15.75" d  
- white laminate panel cabinet with UV graphic on the front and laminate top



**HYBRID PRO COUNTER 04**  
HPC-04

- 73.75" w x 36.5" h x 25.38" d  
- white laminate panel cabinet with UV graphic on the front and laminate top



**HYBRID PRO COUNTER 09**  
REC-42

- 46" w x 37.5" h x 23" d  
- white laminate cabinet with UV graphic on the front, opaque or backlit



**HYBRID PRO COUNTER 10**  
REC-52

- 64" w x 37.5" h x 30" d  
- white laminate cabinet with UV graphic on the front, opaque or backlit



**HYBRID PRO COUNTER 11**  
RCK-06

- 71.06" w x 36.61" h x 32.72" d  
- white laminate panel cabinet with UV graphic on the front and laminate top



All Hybrid Pro Modular counters are also available for rent

## LINEAR™ BOLD COUNTERS

Dress up your space with sophisticated and functional counters. Counter tops are available in four thermoform finishes – silver, black, mahogany and natural. Printed graphic panels create the base of the counter. Counters come standard with locking cabinet door.

Linear counter tops are available in your choice of four thermoform finishes



LN-CU-01



LN-CU-02



LN-CU-03



LN-CU-05



LN-CU-06



LN-CU-07



LN-CU-08



## LINEAR™ COUNTER LN-TBL-SA-RCT

- 3 graphic panels to display custom graphics
- quick & easy-to-assemble, tool included
- fits in an OCH shipping and transport case
- aluminum design is sturdy and stable
- top available in four laminate finishes





FORMULATE® KIOSKS

Formulate® Kiosks couple lightweight aluminum tube frames with state-of-the-art printed stretch zipper pillowcase fabric graphics to create funky and functional multimedia kiosks.



**KIOSK 1**  
FMLT-KIOSK-01

- 29.53" w x 98.53" h x 31.78" d
- pillowcase fabric graphic
- supports medium monitor\*

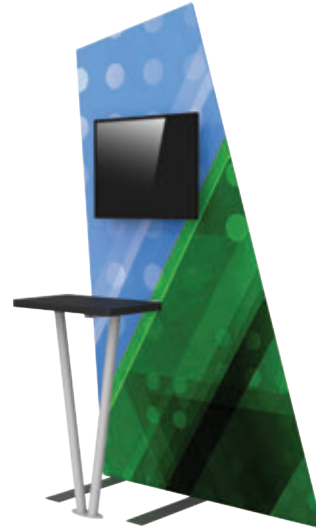

**KIOSK 2**  
FMLT-KIOSK-02

- 61.72" w x 98.16" h x 34.57" d
- pillowcase fabric graphic
- supports medium monitor\*



**KIOSK 3**  
FMLT-KIOSK-03

- 55.12" w x 98.61" h x 36.03" d
- pillowcase fabric graphic
- supports medium monitor\*



**KIOSK 4**  
FMLT-KIOSK-04

- 39.37" w x 92.52" h x 35.75" d
- pillowcase fabric graphic
- supports medium monitor\*

\*Monitor not included.



VECTOR FRAME™ MONITOR KIOSKS

Vector Frame™ Monitor Kiosks are a sleek, stylish way to display media at any tradeshow, event, in a retail or corporate space. The kiosks feature push-fit fabric graphics, easy-to-assemble 4" extrusion frames, your choice of single or double sided graphics and one or two monitor mounts (monitors not included). These kiosks complement the Vector Frame line of banners, backwalls, exhibit kits and counters.



01 Monitor Kiosk  
**VF-MK-01-SS**  
**VF-MK-01-DS**  
 36.3" w x 94.74" h x 19.69" d  
 comes in 1 OCH case  
 supports 32-55" monitor\*;  
 max weight = 80 lbs each



back with graphic



back with graphic & monitor mount\*



top view  
one monitor mount

front with graphic & monitor mount\*



02 Monitor Kiosk  
**VF-MK-02-SS**  
**VF-MK-02-DS**  
 48.11" w x 94.74" h x 19.69" d  
 comes in 1 OCH case  
 supports 32-55" monitor\*;  
 max weight = 80 lbs each



back with graphic



back with graphic & monitor mount\*



top view  
two monitor mounts

front with graphic & monitor mount\*



**LINEAR KIOSK 01**  
LN-K-01

- 54.4" w x 99" h x 23.25" d
- monitor\* mount
- fabric canopy
- approximate weight: 125 lbs



**LINEAR KIOSK 05**  
LN-K-05

- 25.38" w x 72.25" h x 18.5" d
- monitor\* mount
- approximate weight: 30 lbs



**MONITOR KIOSK**  
PM453-MK-M/L

- large or medium monitor\* bracket
- max weight = 40 lbs
- medium holds 32-55"
- large holds 40-65"
- OCFM case optional
- monitor not included\*

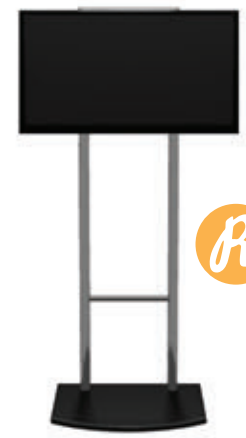

**MONITOR KIOSK**  
VB-MK-01

- medium monitor\* bracket
- max weight = 50 lbs
- comes with 1 OCH2 case
- monitor not included\*



\*Monitors not included.



**ZEDUP 1**  
black: ZD-1-B  
silver: ZD-1-S

- 6 pocket rack
- can be stored or shipped loaded with literature



**ZEDUP LITE**  
silver: ZD-LITE

- 6 pocket rack
- collapsible
- lightweight version of the ZedUp
- constructed from aluminum & plastic for reduced weight

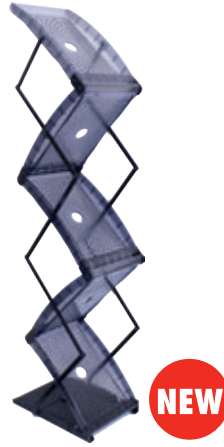

**QUANTUM DOUBLE SIDED**  
black: QNTM-DS

- 5 pocket rack
- collapsible
- constructed from plastic for light weight



**QUANTUM SINGLE SIDED**  
black: QNTM-DS

- 4 pocket rack
- collapsible
- constructed from plastic for light weight



**INNOVATE**  
black: INN-B  
silver: INN-S

- modular design
- 10 pockets
- packs in 3 separate parts for reduced shipping size



**ILLUSION**  
black: IL-1-B  
silver: IL-1-S

- fast-folding cantilever rack
- 4 front facing pockets



**10 UP**  
black: 10UP-B

- strong & stable
- 10 pockets
- packs flat



All literature racks come with a five year limited warranty, a carry bag, and are an eco-friendly choice.

SLIM LINE LED LIGHTING

Lighting can create a powerful, impactful presence or display. Illumination is an important piece of the puzzle to achieve the mood, style and staging that you desire. A variety of Luminosity™ display lights, lighting kits and solutions are available to help clients make their projects and products shine!



**LED FLOOD**  
**LUM-LED4-ORL-B**

- low voltage 12 watt spotlight
- 17.16" long from end to end
- mounts to dovetails and extrusion channel
- available in black only

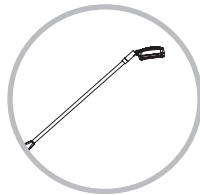

**LED SPOT**  
**LUM-LED3-ORL-B**

- low voltage 5 watt slender spotlight
- 17.18" long from end to end
- mounts to banner stands
- available in black only

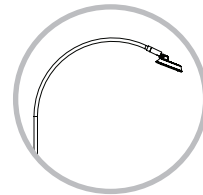

**LED STRIP**  
**LUM-LED5-ORL-B**

- low voltage 12 watt
- 16.1" long from end to end
- mounts to dovetails and extrusion channel
- available in black only

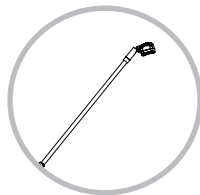

**LED EXHIBITION**  
**LUM-LED6-ORL-B**

- low voltage 12 watt spotlight
- 17.13" long from end to end
- mounts to extrusion channels
- available in black only

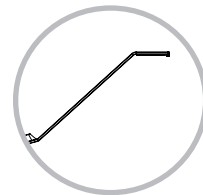

**LUMINA 200 LED**  
**Black: LUM-LED2-ORL-B**  
**Silver: LUM-LED2-ORL-S**

- LED Lumina 200 floodlight
- Uses multi cups chip on board (MCOB) light technology and features a slim profile
- LED rated for 20,000 continuous hours
- 19" long from end to end

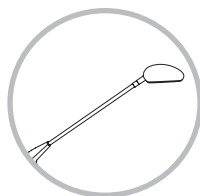

LIGHTING IS AN **IMPORTANT** ELEMENT TO ANY DISPLAY



LIGHTING DRAWS ATTENTION TO YOUR BRAND AND MESSAGE WITH ELEGANCE



LUMINOSITY DISPLAY LIGHTING

Lighting can create a powerful, impactful presence or display. Illumination is an important piece of the puzzle to achieve the mood, style and staging that you desire. A variety of Luminosity™ display lights, lighting kits and solutions to help clients make their projects shine!



**LUMINA 1**

black: LUM-1-B  
chrome: LUM-1-C

- low voltage 50 watt spotlight & universal fittings kit
- "goose neck" arm
- mounts horizontally
- LED option available

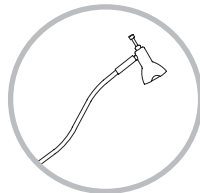

**LUMINA 2**

LUM-2-1

- low voltage 50 watt slender spotlight
- mounts to a vertical pole
- brushed stainless steel finish
- LED option available

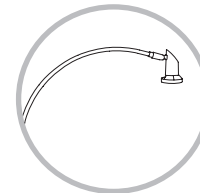

**LUMINA 5**

LUM-5

- low voltage 50 watt spotlight & universal fittings kit
- deluxe chrome head
- telescopic arm
- extends from 7" - 22" long
- LED option available

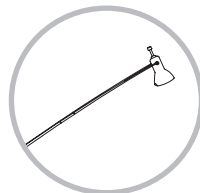

**LUMINA 6**

LUM-6

- low voltage, 50 watt spotlight & universal fittings kit
- stylish curved twin arms
- silk black only
- LED option available

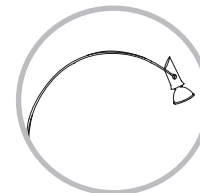

**LUMINA 8**

black: LUM-8-B  
silver: LUM-8-C

- 12 volt spotlight with straight arm & adjustable head
- includes 110 volt UL approved transformer, 50 watt bulb & universal fittings kit
- 17" long from end to end
- LED option available

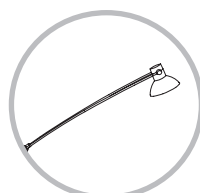

**LUMINA 200 FLOODLIGHT**

LUM-200-ORL

- 110 volt ETL approved wall washer floodlight with a straight arm & adjustable head
- light includes 120 watt halogen bulb
- 19.5" long from end to end
- silk black finish

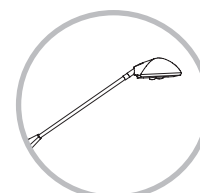

## UNIVERSAL LIGHT CLAMP KIT

UNI-LT-CLP30  
UNI-LT-CLP50

- comes standard with the Lumina 1, 3, 4, 5, 6, 8 and allows our lights to fit a majority of banners, truss & panel kits



## SPT CASE SPT-CASE

- EVA semi-rigid lighting case
- foam-lined padded compartments
- holds two Lumina 200 lights & power supply
- fits Lumina 1, 2, 5, 6, 8 and power supply



## LED BULB OPTION

LUM-LV-LED-BLB16

- a green solution for Lumina 1, 2, 5, 6, 8
- 50 watt equivalent LED bulb



## LUMINA SPARE BULB KIT

LUM-BULB

- (2) 50 watt low voltage spare bulbs in a padded, protective EVA formed case



## FLOODLIGHTS & WALL WASHERS

### LED FLOOD LIGHT

LED-FLOOD

- 85-265 voltage, 42 watt LED Flood light (equivalent to 400 watt halogen)
- projects cool WHITE light
- 7.4" w x 9.44" l x 5.11" d
- angles to 120°
- UL approved



### MINI LED FLOOD LIGHT

LED-10W-FLOOD-RGB  
LED-10W-FLOOD-W

- 10 watt LED Flood light
- projects cool WHITE or RGB spectrum light
- remote control provided with RGB version
- each light measures 4.49" w x 3.39" h x 3.98" d
- angles to 120°
- UL approved



### COLOR BLAST ACCENT LIGHTS

- 85-265 voltage, 13 watt LED blast light
- projects your choice of warm or cool WHITE, and a RGB spectrum flashing pattern
- 7" round x 7" h (when faceplate is flush with base and not angled)
- angles to 60°
- UL approved



**LED-WRM-WHT-BLAST**  
Features a warm white LED light output; good for light-colored and neutral graphic prints. 3,000K



**LED-COOL-WHT-BLAST**  
Features a cool LED light output; good for darker graphic prints. 6,000K



**LED-RGB-BLAST**  
Features multi-pattern flashing RGB LED light output; RGB spectrum cannot be controlled.

CASES

It's critical to protect your tradeshow exhibit investment with a quality constructed transit and shipping case. An extensive selection of exhibit and display cases and crates to choose from that are all made in North America and are designed to house specific lines of exhibits and displays for maximum portability and protection during shipping.

**LIGHTING & ACCESSORY CASE**  
**OCA-2**

- ideal for lights and accessories
- secure straps help to ensure case will remain closed during transport
- interior size:  
32.81" w x 4.13" h x 13.75" d
- exterior size:  
34" w x 7" h x 15" d
- weight when empty: 8 lbs



**SMALL & LARGE GRAPHIC CASES**  
**SMALL: OCS**  
**LARGE: OCL**

- premium latches for maximum strength
- built in wheels and easy-to-grip molded handle

**OCS**

- interior size:  
14" w x 39.81" h x 13.25" d
- exterior size:  
18" w x 42.25" h x 16.5" d
- weight when empty: 18 lbs

**OCL**

- interior size:  
14" w x 51.5" h x 13.25" d
- exterior size:  
18" w x 55.13" h x 16.5" d
- weight when empty: 20 lbs



**BANNER STAND CASE**  
**OCB**

- this expandable shipping case fits up to three swivel-foot banner stands with bags or one premium stand with bag\*
- also used for Formulate® Lite displays
- interior size min/max:  
min - 12" w x 30.13" h x 3.75" d  
max - 12" w x 47.13" h x 3.75" d
- exterior size:  
min - 14.56" w x 30.38" h x 5.88" d  
max - 14.56" w x 47.38" h x 5.88" d
- weight when empty: 9 lbs
- \*case does not fit Uno, Spring 5, Contender 48 or banners over 39.37" wide



**EXPANDABLE CASE**  
**OCE**

- the perfect protective shipping and/or storage case for all Formulate® exhibit kits, hanging structures and accessory products
- adjustable roto-molded expandable display case
- adjustable lid and easy pin latch
- interior size min/max:  
min - 13.75" w x 39.63" h x 11.75" d  
max - 13.75" w x 64" h x 11.75" d
- exterior size min/max:  
min - 16.75" w x 39.88" h x 16.88" d  
max - 16.75" w x 64.25" h x 16.88" d
- weight when empty: 27 lbs
- separate fabric graphic converts the case into a counter



**STANDARD WHEELED DISPLAY CASE**

**OCX**

- light storage in the lid
- premium latches for maximum strength
- interior size: 35.75" w x 23.5" h x 13" d
- exterior size: 39.5" w x 26.75" h x 17" d
- weight when empty: 32 lbs
- optional wood counter top can be added in your choice of silver, black, mahogany or natural



**PREMIUM WHEELED DISPLAY CASE**

**OCP-2**

- premium latches for maximum strength
- hinged lid with internal light storage
- robust, roto-molded plastic
- interior size: 22" w x 35.5" h x 14.14" d
- exterior size: 26" w x 39.56" h x 17.75" d
- weight when empty: 32 lbs



**DELUXE WHEELED DISPLAY CASE**

**OCP-ELITE**

- lid can be used as a step stool while assembling displays
- access door provides storage when unit is used as a counter
- interior size: 14.14" w x 31.75" h x 19.75" d
- exterior size: 16.75" w x 38.25" h x 26.25" d
- weight when empty: 31 lbs



**HOPUP/MEDIUM WHEELED CASE**

**OC-HOP**

- ideal for Hopup backwall displays (fits up to 4x3 hopup)
- built-in handle and wheels for easy transport
- interior size: 13.5" w x 35.5" h x 13.5" d
- exterior size: 15.5" w x 35.69" h x 17" d
- weight when empty: 17 lbs



**LARGE DISPLAY CASE**

**OCH**

- roto-molded case for exhibits, graphics & accessories
- secure reinforced straps help to ensure case will remain closed during transport
- strong yet lightweight
- interior size: 23.25" w x 7.63" h x 46.5" d
- exterior size: 26" w x 12" h x 50" d
- weight when empty: 22 lbs



**LARGE DISPLAY CASE**

**OCH2**

- heavy-duty shipping and storage case
- ideal for Linear hybrid displays
- secure reinforced straps help to ensure case will remain closed during transport
- interior size: 24.13" w x 12.25" h x 47.25" d
- exterior size: 29" w x 15" h x 52" d
- weight when empty: 30 lbs
- wheels and handles recessed



All cases come with a one year limited warranty, are an economic & eco-friendly choice & made in North America.



**FREIGHT CASE**  
**OCHM**

- interlocking surface to enable two cases to be transported together
- maximum case depth = 8" allowing up to 8 flat panels per case
- interior size: 23.75" w x 9.75" h x 36.63" d
- exterior size: 26" w x 14" h x 38" d
- weight when empty: 20 lbs



**FREIGHT CASE**  
**OCFM**

- interlocking surface to enable two cases to be transported together
- maximum case depth= 8" allowing up to 8 flat panels per case
- interior size: 35.75" w x 9.75" h x 47.25" d
- exterior size: 38" w x 15" h x 49" d
- weight when empty: 35 lbs



**FREIGHT CASE**  
**OCF**

- offers the same features and benefits of the OCT in a rectangular shape
- interior size: 48" w x 19.75" h x 35.5" d
- exterior size: 51" w x 24" h x 39" d
- weight when empty: 55 lbs



**FREIGHT CASE**  
**OCF2**

- molded stackable shipping crate 18" deep
- heavy-duty roller bearing recessed in bridge of case
- holds 18 layers of flat panels in horizontal direction
- interior size: 48" w x 18" h x 48" d
- exterior size: 51" w x 23" h x 51" d
- weight when empty: 70 lbs



**LCD MONITOR CASE**  
**OCM**

- black LDPE case designed for LCD monitors
- built in dry erase board to label contents and location
- fits 37 - 47" screens
- includes 3" casters with rubber wheels
- must be shipped freight
- interior size: 45.5" w x 30" h x 5" d
- exterior size: 54" w x 35" h x 16" d
- weight when empty: 97 lbs



**ORBITAL CURVED TRUSS CASE**  
**OCT**

- designed to handle national & international exhibit freight shipments
- offers maximum protection for your exhibit materials
- interior size: 43.5" w x 33" h x 47.25" d
- exterior size: 48" w x 42" h x 51" d
- weight when empty: 138 lbs



\*Woodcrate options available

<b>A</b>	
ACCENTS & ACCESSORIES.....	70, 212
ADVANCE BANNER STAND.....	7
ADVOCATE SIGN STAND.....	75
AMBASSADOR.....	79
APEX OUTDOOR SIGN.....	79
ARCHES.....	154
ATLAS OUTDOOR SIGN.....	30

<b>B</b>	
BACKLIT HOPUP.....	41
BACKLIT COYOTE POPUP TOWER.....	63
BANNER STAND ACCESSORIES.....	7
BANNER STANDS.....	4
BANNER STAND CASE.....	82, 225
BARRACUDA BANNER STAND.....	6
BLIZZARD BANNER STAND.....	32
BLOK BANNERSTAND.....	9
BREEZE 1 & 2 BANNER STANDS.....	12
BUBBLE PANEL FOR COYOTE POPUP.....	63
BULLET HANGING STRUCTURE.....	147

<b>C</b>	
CAFÉ BARRIER.....	15
CAMPAIGN COUNTER.....	74
CAPSULE ILLUMINATED HANGING STRUCTURE.....	147
CASES.....	82, 225
CASE TO COUNTER.....	64
CHARGING STATIONS.....	72, 138
COBRA FABRIC BANNER.....	17, 95
COLOR BLAST ACCENT LIGHTS.....	82, 224
COLUMNS.....	152
CONCAVE SQUARE HANGING STRUCTURE.....	143
CONFERENCE WALLS.....	156
CONTENDER BANNER STAND.....	8
CONVERTIBLE TABLE THROW.....	35
CONVEX TRIANGLE (SHIELD) HANGING STRUCTURE.....	143
COYOTE POPUP DISPLAY SYSTEMS.....	60
COYOTE TOWER.....	63
CRESCENT BANNER STAND.....	9
CUBE HANGING STRUCTURE.....	146
CUBE TOWER/PRISIM TOWER.....	76
CURVE HANGING STRUCTURE.....	145
CURVED HOPUP CONFIGURATIONS.....	41
CYLINDER TOWERS.....	151

<b>D</b>	
DELUXE WHEELED DISPLAY CASE.....	84, 226
DISC HANGING STRUCTURE.....	145
DISPLAY ADDITIONS.....	79
DRAGON FLY BANNER STAND.....	10

<b>E</b>	
ECONOMY RETRACTABLE BANNER STANDS.....	10
ELEVATE BANNER STAND.....	9
EMBRACE PUSH-FIT FABRIC DISPLAYS.....	44
EMBRACE COUNTER.....	46, 74
ENTICE FABRIC BANNER.....	17, 95
EXCALIBUR BANNER STAND.....	6
EXPANDABLE CASE.....	83, 226
EXPOSÉ TELEXCOPIC DISPLAY.....	13
EYE HANGING STRUCTURE.....	147

<b>F</b>	
FABRIC BANNERS.....	21
FABRIC LIGHT BOXES.....	20
FITTED TABLE THROW.....	36
FLIP 20' EXHIBIT KITS.....	126
FLOODLIGHTS & WALL WASHERS.....	82, 224
FOLDING DISPLAY PANELS.....	66
FORMULATE ESSENTIAL BANNER DISPLAYS.....	16, 94
FOOTBALL HANGING STRUCTURE.....	144
FORMULATE TABLETOP DISPLAYS.....	96
FORMULATE BACKWALL CONNECTOR.....	105
FORMULATE CONFERENCE WALLS.....	156
FORMULATE ARCHES.....	154
FORMULATE CHARGING STATIONS.....	72, 138
FORMULATE COLUMNS.....	152
FORMULATE COUNTERS.....	136, 224
FORMULATE CYLINDER TOWERS.....	151
FORMULATE DESIGNER SERIES 10' DISPLAYS.....	116
FORMULATE DESIGNER SERIES 20' DISPLAYS.....	120
FORMULATE DESIGNER SERIES 30' DISPLAYS.....	124
FORMULATE ESSENTIAL BANNER – CURVED.....	16, 94
FORMULATE ESSENTIAL BANNER – STRAIGHT.....	16, 94
FORMULATE ESSENTIAL 8' DISPLAYS.....	96
FORMULATE ESSENTIAL 10' DISPLAYS.....	97
FORMULATE ESSENTIAL TABLETOP DISPLAYS.....	96
FORMULATE ESSENTIAL HANGING STRUCTURES.....	140
FORMULATE FUNNELS.....	150
FORMULATE FUSION KIT 05.....	132
FORMULATE FUSION KIT 06.....	132
FORMULATE FUSION KIT 07.....	133
FORMULATE FUSION KIT 08.....	133
FORMULATE FUSION KIT 09.....	134
FORMULATE FUSION KIT 10.....	134
FORMULATE FUSION KIT 11.....	135
FORMULATE KIOSKS.....	139, 219
FORMULATE LITE 8'/10' DISPLAYS.....	98
FORMULATE MASTER 8' DISPLAYS.....	98
FORMULATE MASTER 10' VERTICAL CURVED DISPLAYS.....	100
FORMULATE MASTER 10' HORIZONTAL CURVED DISPLAYS.....	102
FORMULATE MASTER 10' STRAIGHT DISPLAYS.....	104
FORMULATE MASTER 20' SERPENTINE CURVED DISPLAYS.....	110
FORMULATE MASTER 20' VERTICAL CURVED DISPLAYS.....	112
FORMULATE MASTER 20' HORIZONTAL CURVED DISPLAYS.....	114
FORMULATE MASTER 20' STRAIGHT DISPLAY.....	115
FORMULATE MASTER ACCENTS.....	105
FORMULATE MASTER HANGING STRUCTURES.....	141
FORMULATE SHIELD TOWERS.....	152
FORMULATE UNIVERSAL CONNECTORS & ACCESSORIES.....	99
FORMULATE VIDEO WALLS & ROOMS.....	157
FOUR-SIDED TOWERS.....	151
FOUR-SIDED PINWHEEL.....	146
FOUR-SIDED PYRAMID HANGING STRUCTURE.....	144
FREESTANDING IPAD STANDS.....	71, 212
FREESTANDING TABLET STANDS.....	71, 212
FREIGHT CASE.....	227
FUNNELS.....	150

<b>G</b>	
GIANT MOSQUITO.....	11

<b>H</b>	
HANGING STRUCTURES.....	140
HERO DISPLAY PANELS.....	67
HEXAGON HANGING STRUCTURE.....	146
HOPUP/MEDIUM WHEELED CASE.....	84, 226
HOPUP ACCESSORY KITS.....	42
HOPUP BACKWALL DIMENSION KITS.....	42
HOPUP BACKWALLS.....	38
HOPUP COUNTER.....	40, 74
HOPUP TENSION FABRIC DISPLAYS.....	38
HORIZON™ DISPLAY PANELS.....	68
HYBRID PRO 10' MODULAR BACKWALLS.....	162
HYBRID PRO 20' MODULAR BACKWALLS.....	164
HYBRID PRO COUNTERS.....	168, 217

<b>I</b>	
ILLUMINATED 3D OVAL HANGING STRUCTURE.....	147
ILLUSION LITERATURE RACK.....	77, 221
IMAGINE BANNER STAND.....	6
IMPRINTED TABLE THROW.....	37
INFLATABLE 10' DOME TENT.....	26
INFLATABLE COLUMNS.....	31, 152
INNOVATE LITERATURE RACK.....	77, 221
INTERNAL SHELF KIT.....	63
IPAD STAND.....	138, 212

<b>K</b>	
KIOSKS.....	22, 71, 74, 219, 220

<b>L</b>	
LARGE DISPLAY CASE.....	88, 226
LCD MONITOR CASE.....	227
LED BULB OPTION.....	82, 224
LED EXHIBITION.....	80, 222
LED FLOOD.....	80, 222
LED FLOOD LIGHT.....	80, 140
LED SPOT.....	80, 222
LED STRIP.....	80, 222
LIGHT BOXES.....	20, 172
LIGHTING & ACCESSORY CASE.....	81, 141
LIGHTNING BANNER STAND.....	14
LINEAR PRO 10' DISPLAY SYSTEMS.....	184
LINEAR PRO 20' DISPLAY SYSTEMS.....	184
LINEAR COUNTER.....	186, 218
LINEAR PRO COUNTERS.....	186, 218
LINEAR KIOSKS.....	72, 187
LINEAR UNIVERSAL ACCESSORIES.....	185
LITERATURE RACKS.....	77, 221
L-MINI BANNER STAND.....	14
LUMINA 1.....	81, 223
LUMINA 2.....	81, 223
LUMINA 5.....	81, 223
LUMINA 6.....	81, 223
LUMINA 8.....	81, 223
LUMINA 200 FLOOD LIGHT.....	81, 223
LUMINA 200 LED FLOOD LIGHT.....	81, 223
LUMINA SPARE BULB KIT.....	88, 224
LUMINOSITY DISPLAY LIGHTING.....	81, 223

<b>M</b>	
MERCHANDISE EXPRESS.....	188
MERLIN BANNER STAND.....	9
MINI LED FLOOD LIGHT.....	82, 224
MODULATE.....	88
MONITOR KIOSK.....	74, 220
MONSOON OUTDOOR SIGN.....	32
MOSQUITO BANNER STAND.....	11
MOSQUITO LITE BANNER STAND.....	11

<b>O</b>	
OASIS BAG HOLDER.....	79
OBSERVE DELUXE SIGN STAND.....	75
OBSERVE GRAND SIGN STAND.....	75
OBSERVE PRO SIGN STAND.....	75
OCA-2 DISPLAY CASE.....	83, 225
OCB DISPLAY CASE.....	83, 225
OCE DISPLAY CASE.....	83, 225
OCF.....	227
OCF2.....	227
OCFM.....	227
OCH DISPLAY CASE.....	84, 226
OCH2 DISPLAY CASE.....	84, 226
OC-HOP DISPLAY CASE.....	84, 226
OCL DISPLAY CASE.....	83, 225
OCM.....	227
OCP-2 DISPLAY CASE.....	84, 226
OCP-2 CASE TO COUNTER CONVERSION.....	64
OCP-ELITE DISPLAY CASE.....	84, 226
OCP ELITE CASE TO COUNTER CONVERSION.....	64
OCS DISPLAY CASE.....	83, 225
OCT.....	226
OCX DISPLAY CASE.....	83, 225
OCX CASE TO COUNTER CONVERSION.....	64
ORBITAL CURVED TRUSS CASE.....	227
ORBITAL EXPRESS TRUSS COUNTERS AND PODIUMS.....	209
ORBITAL EXPRESS TRUSS INTERNAL SHELVING.....	208
ORBITAL EXPRESS TRUSS KIOSKS.....	211
ORBITAL EXPRESS TRUSS LAMINATE TABLETOPS.....	208
ORBITAL EXPRESS TRUSS LIT RACK.....	208
ORIENT 1 BANNER STAND.....	8
ORIENT 2 BANNER STAND.....	8
OUTDOOR DISPLAYS.....	25
OUTDOOR SIGNAGE.....	30

<b>P</b>	
PACIFIC BANNER STAND.....	8
PANEL HANGING STRUCTURE.....	145
PARKWAY OUTDOOR POLE BANNERS.....	31
PEGASUS LINKING KIT.....	13
PEGASUS STANDARD.....	13
PEGASUS SUPREME.....	13
PHOENIX BANNER STAND.....	12
PHOENIX MINI BANNER STAND.....	12
PINWHEEL HANGING STRUCTURE.....	144
POSTER FRAMES.....	78
POSTER SNAPPER.....	78
PREMIUM RETRACTABLE BANNER STANDS.....	6
PREMIUM WHEELED DISPLAY CASE.....	84, 226
PRINTED TABLE THROW.....	35
PRISM TOWER.....	76
PROMOTIONAL UMBRELLAS.....	33

## Q

QUANTUM DOUBLE SIDED.....	77, 221
QUANTUM SINGLE SIDED.....	77, 221
QUICKSTAND.....	10

## R

RECTANGLE HANGING STRUCTURE.....	144
RING HANGING STRUCTURE.....	141
ROUND PROMOTIONAL UMBRELLA.....	33
ROUND TABLE THROWS.....	36
ROUNDED SQUARE HANGING STRUCTURE.....	146
RUNNERS.....	35

## S

S-CURVE HANGING STRUCTURE.....	145
SIGN STANDS.....	75
SHIELD TOWERS.....	152
SLIMLINE LED LIGHTING.....	80, 222
SMALL & LARGE GRAPHIC CASES.....	83, 222
SNAP FRAMES.....	78
SNAPPER STAND.....	75
SOLO BANNER STAND.....	10
SPARTAN BANNER STAND.....	75
SPRING 3 BANNER STAND.....	14
SPRING 5 BANNER STAND.....	32
SPRING 7 BANNER STAND.....	14
SPT LIGHT CASE.....	82, 224
SQUARE HANGING STRUCTURE.....	142
SQUARE MOBILE HANGING STRUCTURE.....	148
SQUARE PROMOTIONAL UMBRELLA.....	33
STANDARD BANNER STANDS.....	8
STANDARD WHEELED DISPLAY CASE.....	84, 226
START BANNER STAND.....	10
STEP STOOL.....	79
STRAIGHT HOPUP CONFIGURATIONS.....	40
STOWAWAY OUTDOOR SIGN.....	33
STRETCH TABLE THROW.....	36
SYMPHONY COUNTERS.....	73, 137, 215

## T

TABLE RUNNERS.....	35
TABLE THROWS.....	35
TAPERED RING HANGING STRUCTURE.....	142
TAPERED SQUARE HANGING STRUCTURE.....	142
TAPERED TRIANGLE HANGING STRUCTURE.....	143
TENSION FABRIC COUNTERS.....	71, 212
TENSION FABRIC IPAD STANDS.....	71, 212
THUNDER BANNER STAND.....	32
TIERED BULLET HANGING STRUCTURE.....	149
TIERED RING HANGING STRUCTURE.....	149
TIERED RING FLAT HANGING STRUCTURE.....	149
TIERED SQUARE HANGING STRUCTURE.....	148
TOWERS.....	151
TRAPPA LIGHTBOX.....	78
TRAPPA POST.....	76
TRAPPA POSTER FRAME.....	78
TRIANGLE HANGING STRUCTURE.....	143
TRIO BANNER STAND.....	13
TRIO LITERATURE POCKET.....	13
TRI-TOWER DELUXE.....	76
TRUSS MONITOR MOUNTS.....	211
TUBULAR 10' DOME TENT.....	27

## U

UNIVERSAL LIGHT CLAMP KIT.....	82, 224
UNIVERSAL TABLET STAND.....	71, 212

## V

VECTOR FRAME 10' ESSENTIAL EXHIBIT KITS.....	176
VECTOR FRAME 20' ESSENTIAL EXHIBIT KITS.....	177
VECTOR FRAME 10' MASTER EXHIBIT KITS.....	178
VECTOR FRAME 20' MASTER EXHIBIT KITS.....	180
VECTOR FRAME BANNERS.....	21, 173
VECTOR FRAME COUNTERS.....	183, 216
VECTOR FRAME CURVED BANNERS.....	22, 174
VECTOR FRAME EDGE POSTER FRAMES.....	23, 175
VECTOR FRAME LIGHT BOXES.....	20, 172
VECTOR FRAME MONITOR KIOSKS.....	22, 174, 220
VECTOR FRAME TABLETOPS.....	182
VIBE 10' EXHIBIT KITS.....	128
VOYAGER FOLDING PANELS.....	69

## W

WEDGE OUTDOOR SIGN HOLDER.....	79
WHEELED CASE.....	84, 226
WHIRLWIND.....	30
WIND DANCER OUTDOOR DISPLAYS.....	30
WIND DANCER LT OUTDOOR DISPLAYS.....	30
WIND DANCER MINI OUTDOOR DISPLAYS.....	30

## X

XCLAIM FABRIC POPUP.....	53
XCLAIM FULL HEIGHT KITS.....	55
XCLAIM TABLETOP KITS.....	54

## Z

ZEDUP 1 LITERATURE RACK.....	77, 221
ZEDUP LITE LITERATURE RACK.....	77, 221
ZOOM 10' POPUP TENT.....	26
ZOOM 20' POPUP TENT.....	27
ZOOM BACKPACK FLAGS.....	31
ZOOM BASE OPTIONS.....	29
ZOOM FLEX FLAGS.....	28
ZOOM POPUP TENTS.....	26

## #

10' HERCULES KITS.....	194
10 UP LITERATURE RACK.....	77, 221
20' HERCULES KITS.....	195

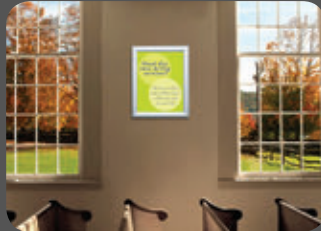
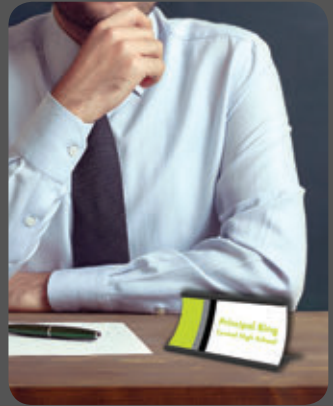

# Wayfinding 101: Directional Signage Solutions

THE SIGN MAKERS™  
**HANDBOOK**  
WAYFINDING SYSTEMS

[www.signmakers-handbook.com](http://www.signmakers-handbook.com)

AMERICA'S  
*FAVORITE*  
TRADESHOW SUPPLIER

[www.theexhibitorshandbook.com](http://www.theexhibitorshandbook.com)

LET'S TALK!

LEADERS *in three dimensional marketing,*  
*Visual* PRESENTATION SYSTEMS  
EXHIBIT & DISPLAY *Solutions*